

# MTX-MRX Editor User Guide

MTX-MRX Editor is software for connecting, constructing, and controlling a system that uses MTX series, MRX series, XMV series, EXi8/EXo8, R series (AD/DA), and Tio1608-D units. The settings you make in MTX-MRX Editor are sent to the MTX series, MRX series, XMV series, EXi8/EXo8, R series (AD/DA), and Tio1608-D units that are connected via Ethernet.

After the settings have been sent, the system will operate without a computer.

The control panel of a DCP series unit or an MCP1 can also be used to control the system in real time.

A paging system can be constructed using PGM1/PGX1 units.

If you're using the MRX, refer also to the "MRX Designer User Guide."

## Notice regarding data copyright

The unauthorized copying or reuse of commercially sold music/sound data without permission from the rights holder is forbidden by law, with the exception of uses that are permitted by copyright law. Before using this data, please obtain permission from the copyright owner, or consult a copyright specialist.

## Notice regarding the content of this user guide

- All copyrights for this software and user guide are the property of Yamaha Corporation.
- Unauthorized copying or modification of this software or user guide in part or in whole is prohibited.
- Please be aware that Yamaha Corporation accepts no responsibility for any results or consequences that may follow from the use of this software and user guide.
- All of the illustrations and screen shots in this user guide are provided for the purpose of explaining the operation. For this reason, they may differ from the actual specifications.
- Changes in the system software, the functionality, and the specifications that may result from updates to the application will be dealt with in a separate leaflet or manual.
- Ethernet is a trademark of the Xerox Corporation.
- Windows is a registered trademark of Microsoft Corporation USA in the United States and in other countries.
- iPad and Bonjour are trademarks of Apple Inc. registered in the United States and in other countries.
- iOS is a trademark or registered trademark of Cisco Inc. in the United States and in other countries, and is used under license.
- The SDHC logo and the SD logo are trademarks of SD-3C, LLC.



- Company names and product names appearing in this document are the trademarks or registered trademarks of their respective owners.

# Contents

<b>Notice regarding data copyright .....</b>	<b>1</b>	<b>Chapter 3. Project screen .....</b>	<b>34</b>
<b>Notice regarding the content of this user guide.....</b>	<b>1</b>	<input type="checkbox"/> System selection tabs .....	34
<b>Chapter 1. An overview of MTX-MRX Editor ....</b>	<b>4</b>	<input type="checkbox"/> HIDE/SHOW button.....	34
<b>An audio system control network .....</b>	<b>4</b>	<b>Network devices .....</b>	<b>35</b>
<b>Terms used in this user guide .....</b>	<b>4</b>	<b>MTX/MRX system.....</b>	<b>36</b>
<b>Data handled by MTX-MRX Editor .....</b>	<b>6</b>	<input type="checkbox"/> “Device Configuration Wizard” dialog box.....	37
<b>Connection requirements for an MTX/MRX system.....</b>	<b>7</b>	<input type="checkbox"/> YDIF-connected devices .....	47
<b>MTX/MRX system configuration examples..</b>	<b>9</b>	<input type="checkbox"/> Digital control panel, PGM1/PGX1 .....	49
<b>What are YDIF connections? (Cascade mode and Distribution mode) ..</b>	<b>10</b>	<input type="checkbox"/> Analog-connected devices .....	50
<b>What are Dante connections? (Daisy-chain connection and Star connection).....</b>	<b>13</b>	<input type="checkbox"/> DANTE-connected devices.....	51
<input type="checkbox"/> Daisy-chain connection.....	13	<input type="checkbox"/> MCP1 .....	52
<input type="checkbox"/> Star connection.....	13	<b>[System] tab .....</b>	<b>53</b>
<input type="checkbox"/> About redundant networks.....	14	<b>[Device] tab .....</b>	<b>54</b>
<b>Patching .....</b>	<b>15</b>	<b>[Alert] tab .....</b>	<b>56</b>
<b>Workflow .....</b>	<b>18</b>	<b>Chapter 4. System screen .....</b>	<b>57</b>
<b>About the screens .....</b>	<b>26</b>	<b>“MAIN” screen .....</b>	<b>60</b>
<input type="checkbox"/> Project screen .....	26	<input type="checkbox"/> “Input Patch” dialog box.....	71
<input type="checkbox"/> System screen .....	26	<input type="checkbox"/> “Output Patch” dialog box.....	72
<b>Moving between screens.....</b>	<b>27</b>	<b>“INPUT” screens .....</b>	<b>73</b>
<b>Chapter 2. Menu bar and tool buttons.....</b>	<b>28</b>	<b>“MATRIX” screen.....</b>	<b>86</b>
<b>Title bar.....</b>	<b>28</b>	<b>“ZONE” screen .....</b>	<b>90</b>
<b>Menu bar .....</b>	<b>28</b>	<b>“ROUTER” screen.....</b>	<b>98</b>
<b>Tool buttons.....</b>	<b>32</b>	<b>“OUTPUT” screens .....</b>	<b>100</b>
		<b>“EFFECT” screen.....</b>	<b>108</b>
		<b>“DCA” screen.....</b>	<b>110</b>
		<b>“I/O” screen .....</b>	<b>112</b>
		<b>“MY4-AEC” screen .....</b>	<b>114</b>
		<input type="checkbox"/> “To Far-end” screen.....	117
		<input type="checkbox"/> “Near-end Voice” screen .....	118
		<input type="checkbox"/> “Mic” screen.....	119

**“EXT. I/O” screen ..... 120**

- ❑ “YDIF” screen (Distribution mode) ..... 120
- ❑ “YDIF In Patch” dialog box ..... 123
- ❑ “YDIF Out Patch” dialog box ..... 123
- ❑ “Channel Select” dialog box ..... 124
- ❑ “YDIF” screen (Cascade mode) ..... 125
- ❑ “ANALOG” screen ..... 126
- ❑ “Line Out Patch” dialog box ..... 127
- ❑ “DANTE” screen ..... 128

**“EXi8” screen ..... 130**

- ❑ “EXi8 Patch” dialog box ..... 131

**“R/Tio” screen ..... 132**

**“EXo8” screen ..... 134**

- ❑ “EXo8 Patch” dialog box ..... 135

**“XMV” screen ..... 136**

- ❑ “XMV Patch” dialog box ..... 138

**Chapter 5. Online and Synchronization ..... 139**

**Online ..... 139**

- ❑ “Synchronization” dialog box ..... 139
- ❑ “Go online – From devices” dialog box ..... 142

**Synchronization ..... 143**

**Chapter 6. Presets ..... 145**

- ❑ “Preset” dialog box ..... 145
- “Settings” dialog box ..... 150
  - “GPI Out” dialog box ..... 152
  - “SD Play” dialog box ..... 153
- Recall Filter setting screen ..... 156

**Chapter 7. Dialog boxes/Software applications ..... 163**

- ❑ “Startup” dialog box ..... 163
- ❑ “Network Setup” dialog box ..... 164
- ❑ “Device Information” dialog box ..... 165
  - “Update Firmware” dialog box ..... 167
  - “IP Address” dialog box ..... 169
  - “Auto-Assign IP Address” dialog box ..... 172

- ❑ “Match Device by IP Address” dialog box ..... 173
- ❑ “MTX Configuration” dialog box ..... 176
- ❑ “Dante Information” dialog box ..... 179
- ❑ “Word Clock” dialog box ..... 180
- ❑ “Clock” dialog box ..... 182
- ❑ “Daylight Saving Time” dialog box ..... 184
- ❑ “Scheduler” dialog box ..... 186
- ❑ “Remote Control” dialog box ..... 196
- ❑ “Digital Control Panel” dialog box ..... 197
- ❑ “Wireless DCP” dialog box ..... 202
- ❑ “MCP1” dialog box ..... 204
- ❑ “PIN Setup” dialog box ..... 209
- ❑ “Label” dialog box ..... 210
- ❑ “Re-size Image” dialog box ..... 212
- ❑ “PGM1/PGX1” dialog box ..... 213
- ❑ “PGM1 Label Creator” application ..... 216
- ❑ “GPI” dialog box ..... 219
- ❑ “GPI Calibration” dialog box ..... 221
- ❑ “Security Settings” dialog box ..... 223
- ❑ “Project Information” dialog box ..... 224
- ❑ “Configuration Diagram” dialog box ..... 225
- ❑ “Get Log” dialog box ..... 226
- ❑ “Sampling Rate Converter” dialog box ..... 227
- ❑ “Input Source/Redundant” dialog box ..... 228

**Appendix ..... 230**

**List of settings in “Settings” dialog boxes ..... 230**

- DCP/Wireless DCP/MCP1 ..... 230
- GPI Input ..... 245
- GPI Output ..... 250

**Workflow for paging settings ..... 255**

**Settings for controlling devices across subnets ..... 258**

**Alert list ..... 261**

**Troubleshooting ..... 267**

# Chapter 1. An overview of MTX-MRX Editor

## An audio system control network

When multiple MTX series, MRX series, XMV series, EXi8/EXo8, R series (AD/DA), and Tio1608-D units are connected to an Ethernet network, they will operate together as a single audio system. This is called an “MTX/MRX system,” and a space containing multiple MTX/MRX systems is called a “project.” If a computer is connected to the network, the computer can control the MTX/MRX system via the MTX/MRX.

## Terms used in this user guide

### ● YDIF

This is a digital audio transmission format that uses Ethernet cables to send and receive up to 16 channels of audio and word clock. YDIF makes it easy to connect MTX units to share buses and expand the number of input/output channels (Cascade mode), or to connect MRX and XMV/EXi8/EXo8 units so that digital audio signals can be conveyed without deterioration (Distribution mode).

\* If the MRX is part of an MTX/MRX system, only Distribution mode is available.

This format does not include control signals. To send and receive control signals, you must separately connect the NETWORK connectors.

### ● Dante

This is a digital audio transmission format developed by the Audinate Corporation that uses Ethernet cables to send and receive up to 1024 channels of audio together with word clock and control signals. An MTX/MRX system can use up to 64 channels, and there can be a maximum of 256 channels for the entire project.

### ● UNIT ID

This is a unique ID that is assigned to the MTX/MRX, XMV, EXi8, EXo8, PGM1, MCP1, R series (AD/DA), and Tio1608-D.

The unit ID is specified on the rear panel of each unit. On the MCP1, this is specified in the utility screen of the unit.

### ● Panel ID

This is a unique ID assigned to a DCP. It must not conflict between DCP units that are connected to the same MTX/MRX.

The panel ID is specified for each DCP.

### ● Components and parameters

Audio processing modules such as equalizers and compressors are called “components.”

Editable elements of a component are called “parameters.”

### ● Configuration

This is the basic group of parameters, which you will set first in MTX-MRX Editor. Here you will specify how audio is patched between the MTX/MRX and the other external devices.

These settings are not included in a preset file.

### ● **Preset**

A preset is a set of parameters. Presets can be recalled from a DCP unit, a wireless DCP, or an MCP1 unit, via GPI, from an MTX unit or MRX unit, or from MTX-MRX Editor. Fifty presets can be stored in an MTX/MRX system.

### ● **Emergency mode**

If the “Preset” dialog box’s [Emergency Recall] setting is [ON], the MTX/MRX will enter this mode when it receives an EMG (Emergency) signal from an external device, or when the input to the +24V [GPI IN] pin (IN 8 for the MTX3, and IN 16 for the MTX5-D and MRX7-D) falls below 2.5V. In this mode, the unit will operate as follows.

- The current state will be remembered. This remembered state is used to return to the original state when the unit exits Emergency mode.
- The preset specified by the “Preset” dialog box’s [Emergency Recall] setting will be recalled.
- Operations from an external controller such as a DCP will no longer be received. (On the MCP1, only the utility page can be operated.)
- If [Block all paging] is selected in the “PGM1/PGX1” dialog box, the entire paging system including the scheduler will stop.
- The unit will be taken offline from MTX-MRX Editor.
- All MTX/MRX units in the same MTX/MRX system will enter Emergency mode.

# Data handled by MTX-MRX Editor

## Project file (.mtx)

### Configuration

#### Device structure<sup>\*1</sup>

The type and number of devices, their UNIT ID, and YDIF connection order

#### MTX/MRX system settings<sup>\*2</sup>

YDIF mode

Device name

“Preset” dialog box

“Security Setting” dialog box ([File] menu)

“Project Information” dialog box ([File] menu)

Contents of “Set IP Address” in the “Device Information” dialog box ([System] menu)

“MTX Configuration” dialog box ([System] menu)

“Daylight Saving Time” dialog box ([System] menu)

“Scheduler” dialog box ([System] menu)

“GPI” dialog box ([System] menu)

“Remote Control” dialog box ([System] menu)

Library of the “Digital Control Panel” dialog box ([Controller] menu)

Library of the “Wireless DCP” dialog box ([Controller] menu)

Function Assign of the “PGM1/PGX1” dialog box ([Controller] menu)

Dimmer on/off and Input Source/Redundant settings ([Device] tab)

Patching in the “EXT. I/O” screen between the MTX/MRX and external devices (YDIF connections, analog connections, Dante connections)

Pilot Tone setting in the [I/O] screen

\*1 Synchronization is not possible if the device configuration is different.

\*2 This will not change even if the preset is switched.

### Preset

MTX/MRX sources for YDIF in the “EXT. I/O” screen

Parameters<sup>\*3</sup> for MTX/MRX components

Assignments to DCP library presets

Assignments to Wireless DCP library presets

Assignments to MCP1 library presets

GPI Out status

[SD Song Select & Play]

Parameters of the EXi8/EXo8/XMV/R series (AD/DA)/Tio1608-D

MY4-AEC parameters (except for AES/EBU)

\*3 The MRX’s component parameters are managed as snapshots of parameter sets. They are associated with presets by registering a snapshot in a preset. For more about snapshots, refer to “MRX Designer User Guide.”

## Speaker Processor Library (.ce3)

**NOTE** Even if you modify the configuration, the changes will not be reflected in previously-stored presets. After modifying a configuration, you must (if necessary) recall the preset and then store it again.

# Connection requirements for an MTX/MRX system

The requirements for an MTX/MRX system are as follows.

A maximum of 80 devices such as MTX/MRX/EXi/EXo/XMV/R series (AD/DA)/Tio1608-D/MCP1/PGM1 units can belong to one project.

## **Overall MTX/MRX system (① in diagram below)**

- The XMV/R series (AD/DA)/Tio1608-D is controlled from MTX-MRX Editor via the MTX/MRX
- A maximum of 20 devices such as MTX/MRX/EXi/EXo/XMV/R series (AD/DA)/Tio1608-D units can belong to one MTX/MRX system
- A maximum total of 20 devices such as PGM1/MCP1 units can belong to one MTX/MRX system
- Only one computer at a time can access the MTX/MRX system

## **Devices connected to each other via YDIF connection (② in diagram below)**

- Maximum total of eight units (maximum of four MTX/MRX units)
- At least one MTX/MRX unit must be included

## **Control panels connected to the MTX/MRX (③ in diagram below)**

- For each MTX/MRX unit, there can be a maximum of eight digital control panels (DCP) belonging to the MTX/MRX system
- For each MTX/MRX unit, there can be a maximum of eight wireless DCP units belonging to the MTX/MRX system
- A maximum of four PGM1 units can belong to one MTX/MRX system

## **XMV connected via analog to the MTX/MRX (④ in diagram below)**

- A maximum of 20 units for the entire MTX/MRX system, including the XMV units included here

## **Devices connected to the MTX/MRX via Dante (⑤ in diagram below)**

- A maximum of 20 units for the entire MTX/MRX system, including the XMV units included here
- A maximum of eight R series (AD/DA) and Tio1608-D units can belong to one MTX/MRX system

## **MCP1 units connected to the MTX/MRX (⑥ in diagram below)**

- Up to a total of 16 units
- All MTX/MRX units within the MTX/MRX system can be controlled

The following diagram shows these requirements applied in MTX-MRX Editor's Project screen.

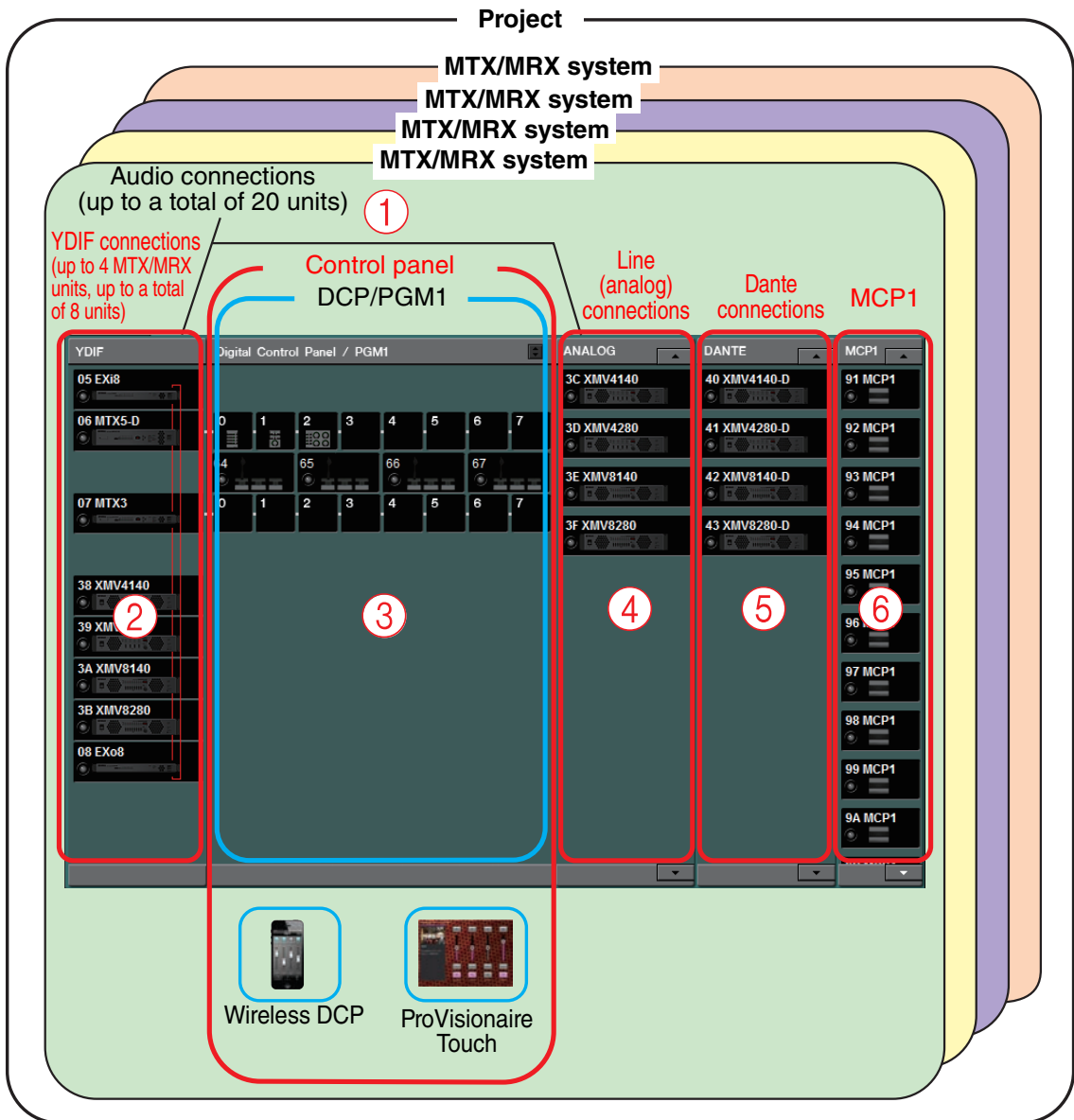

# MTX/MRX system configuration examples

## Example 1

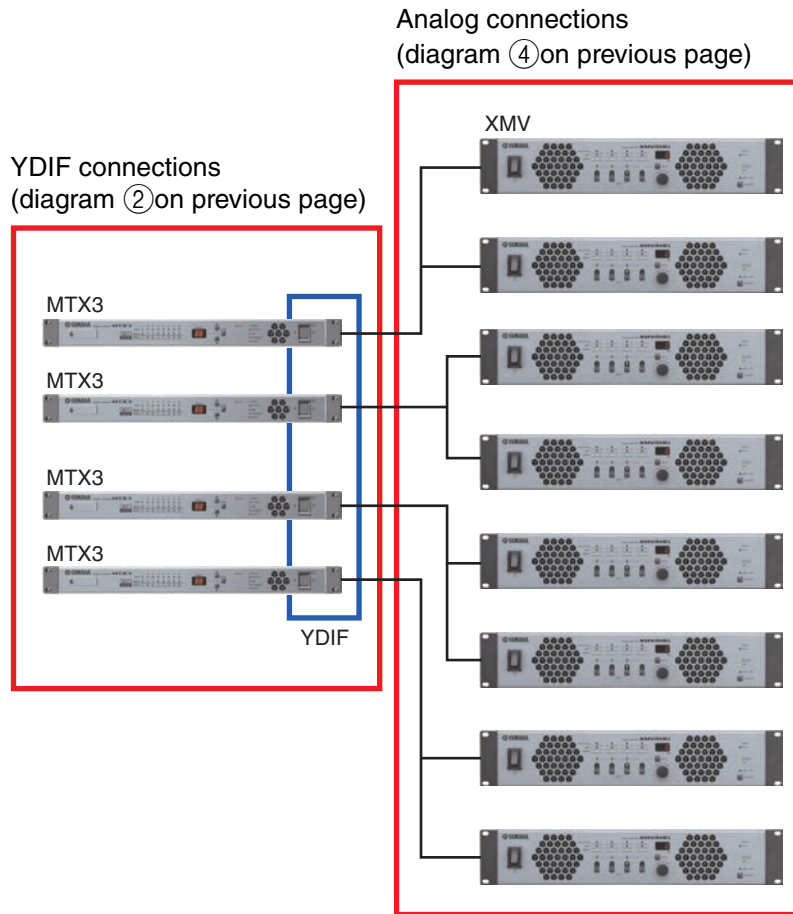

## Example 2

YDIF connections (diagram ② on previous page)

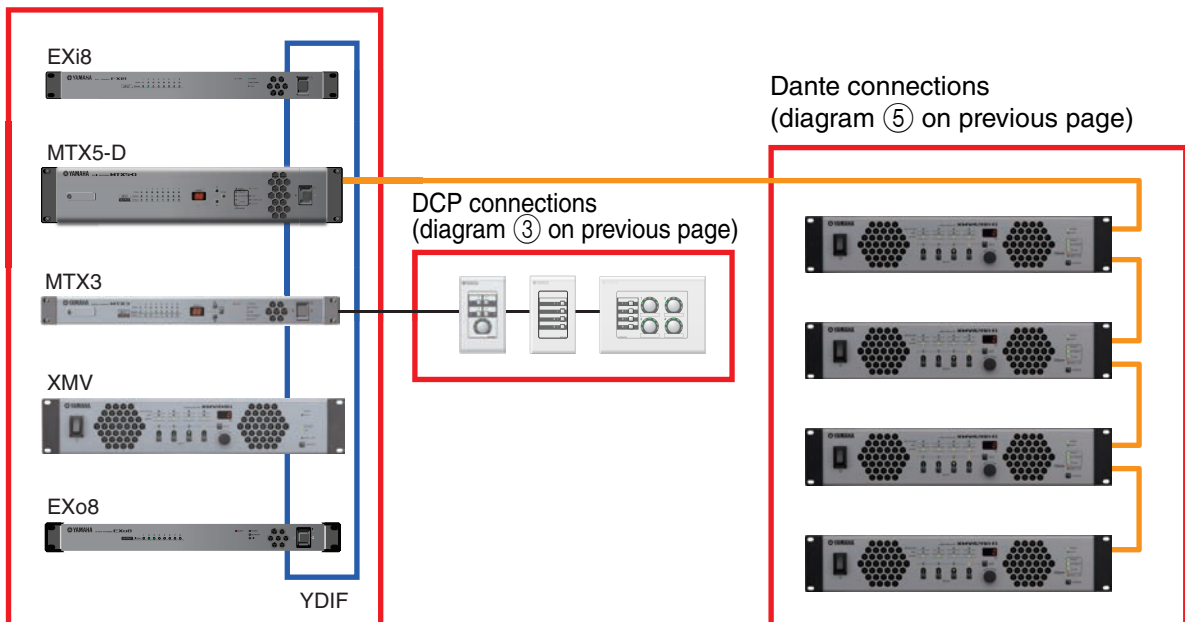

# What are YDIF connections? (Cascade mode and Distribution mode)

An MTX/MRX system has the following two connection modes. When connecting multiple YDIF devices (when making YDIF connections), you must choose one of these modes. In either case, the system can easily be expanded at low cost.

Use the “Device Configuration Wizard” dialog box to switch modes.

## ● Cascade mode

This allows up to eight channels of matrix buses to be shared between multiple MTX units. Mic inputs can be expanded to a maximum of 32 channels, and eight mixes can be created.

In cascade mode, YDIF is used as the internal bus; this means that an EXi8 on the input side and an EXo8/XMV on the output side cannot be connected via YDIF.

**NOTE** *Cascade mode cannot be selected if the MTX/MRX system includes an MRX unit.*

## ● Distribution mode

This is used when inputting audio signals from an EXi8 to an MTX/MRX, when inputting/outputting between MTX/MRX units, and when outputting from an MTX/MRX to an XMV/EXo8. This allows a single audio signal to be distributed to multiple output destinations. An MTX/MRX and XMV can be digitally connected via YDIF to easily construct a high-quality system.

If only MTX units are connected

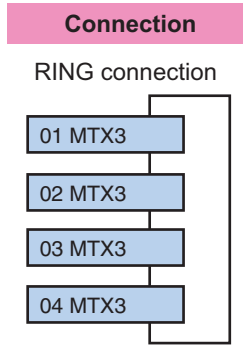

Up to four MTX units can be connected. Connections can be in any order.

Use the [Device Configuration Wizard] to switch both settings.

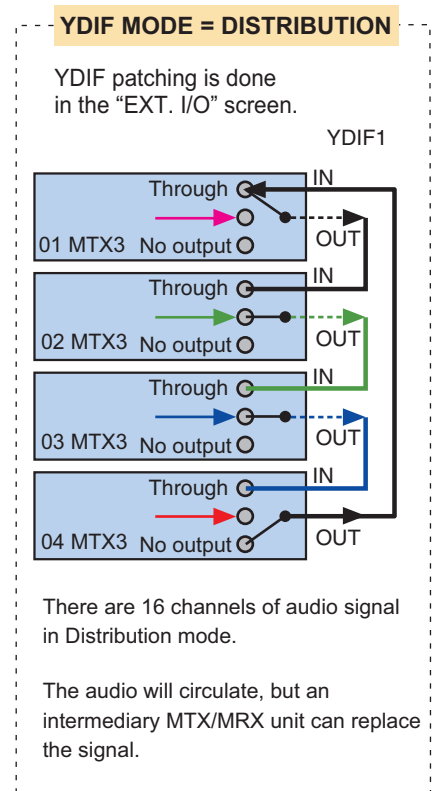
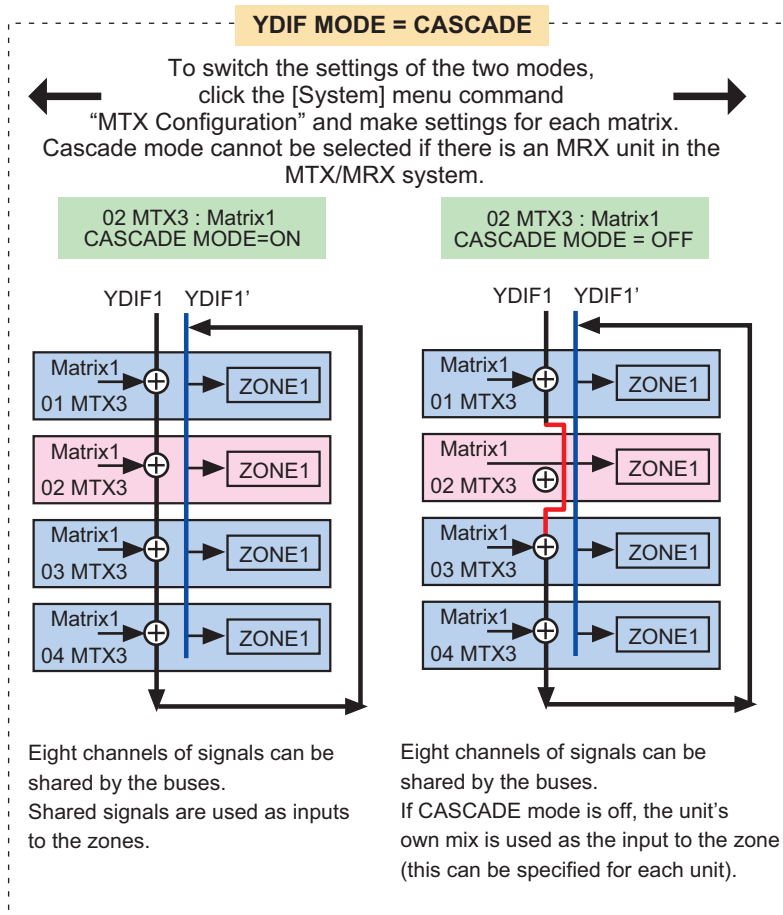

If MTX/MRX units and other YDIF units are connected

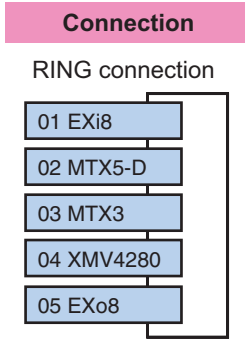

Up to eight units can be connected via YDIF. Connections can be in any order.

**Cascade mode**

If a device other than an MTX is connected, it is not possible to select Cascade mode.

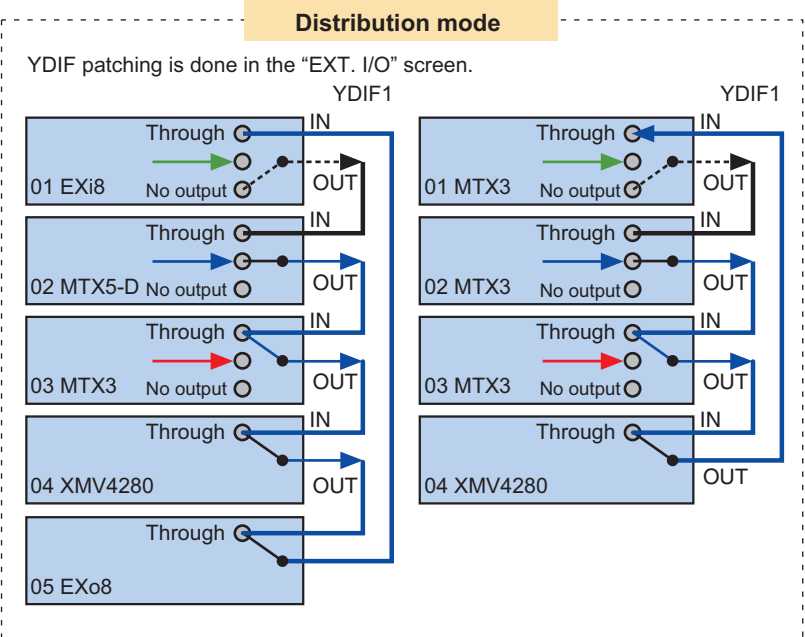

There are 16 channels of audio signal in Distribution mode. The audio will circulate, but an intermediary MTX/MRX unit can replace the signal. The XMV is only able to receive. When connected via YDIF, the XMV will send the audio signals without change to the EXi8/EXo8 or the MTX/MRX. The audio signal will loop unless the EXi8/MTX/MRX unit outputs a different signal or the output is stopped.

**<Example of using Distribution mode>**

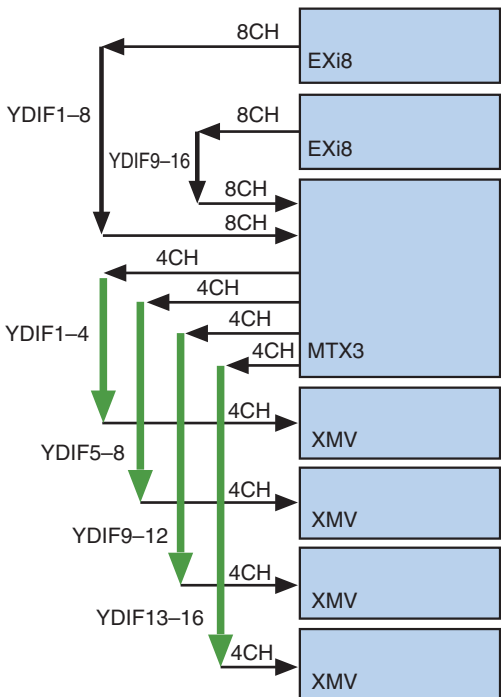

# What are Dante connections? (Daisy-chain connection and Star connection)

A Dante network can be connected in two ways.

Set the DIP switches of the devices as appropriate for the type of connection.

## □ Daisy-chain connection

---

In a daisy-chain connection, each device is connected to the next device, in a chain. This method makes it simple to construct a network, and does not require a network switch. Use this method for simple systems in which a relatively small number of units are to be connected.

As the number of connected units increases, you will need to increase the latency. Also, if a problem such as a broken cable occurs, the network will be disconnected at that point, and communication with units beyond that point will be impossible.

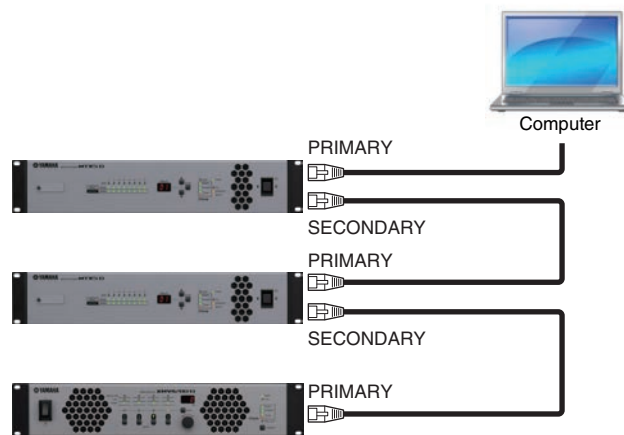

## □ Star connection

---

In a star connection, devices are connected with a network switch at their center. By using a network switch that supports gigabit Ethernet, you can create even large-scale networks that require high bandwidth. We recommend that you use a network switch that supports functionality for controlling and monitoring the network (e.g., QoS, which gives priority to clock synchronization and audio transmission for specified data routings).

With this type of connection, it is typical to create a redundant network so that audio will continue being conveyed even if a problem occurs with the network.

## □ About redundant networks

A redundant network is a network consisting of two circuits: a primary circuit and a secondary circuit. Normally, communication occurs on the primary circuit, but if a problem such as a broken cable occurs on the primary circuit, communication will automatically switch to the secondary circuit. By using this type of connection with a star connection, you can construct an environment that is more resistant to network problems than a daisy-chained network.

**NOTE** In order to communicate with MTX-MRX Editor or a Wireless DCP when operation has switched to the secondary Dante connection, you must re-connect the computer or Wi-Fi access point to the secondary Dante network switch.

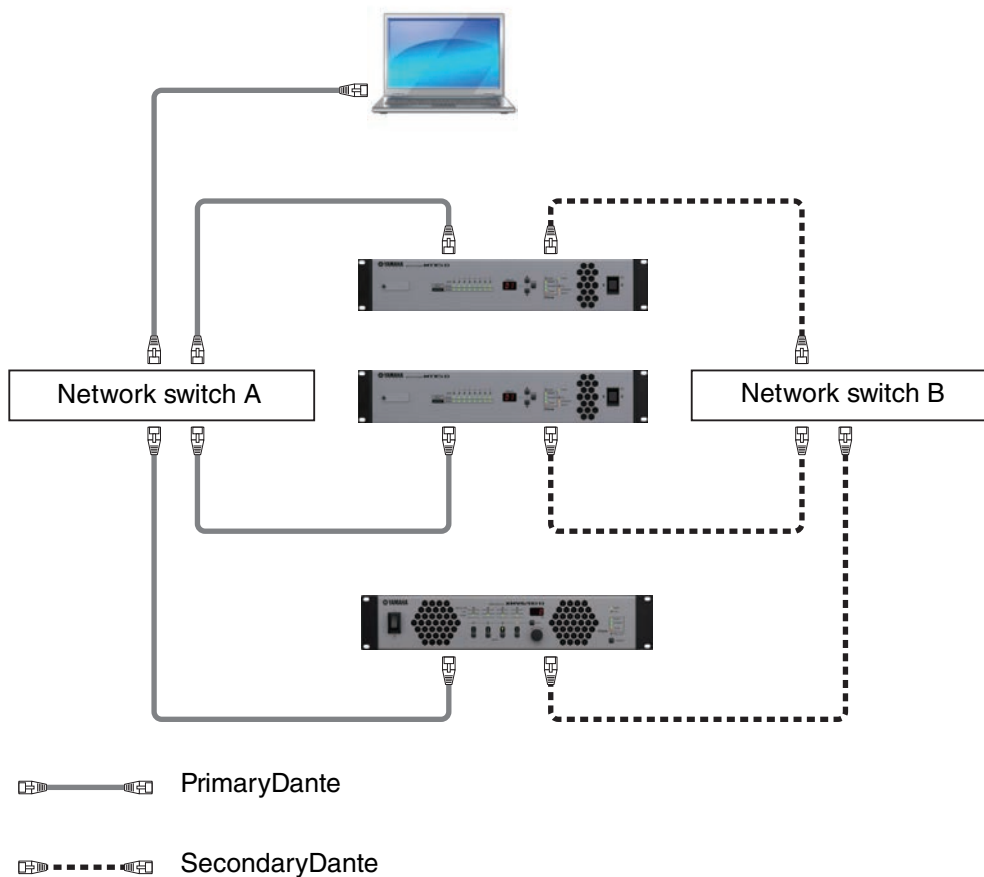

# Patching

In a digital audio network such as YDIF or Dante that comprises the MTX/MRX system, you will make settings on the transmitting device to specify “which output channel/bus’s signals will be sent to which channels of the digital audio network,” and make settings on the receiving device to specify “which channels of the digital audio network will be received on which input channels.”

This type of patching mechanism allows the signal of one channel of the digital audio network to be received by multiple devices.

In MTX-MRX Editor, settings for transmission/reception within the MTX unit are made in the “MAIN” screen, settings for transmission/reception within the MRX unit are made in the “MRX Designer” window, and settings for transmission/reception with external devices such as the XMV or EXi8 are made in the “EXT. I/O” screen.

Settings for connecting the MTX/MRX’s analog output to the XMV’s analog input are also made in the “EXT. I/O” screen.

By making patching settings for the MTX and external devices in the “EXT. I/O” screen, the parameters of an external device can be edited in the parameter edit screen that appears when you click the port/external device parameter recall button in the “MAIN” screen of the MTX.

External device settings can also be edited in the “EXi8,” “EXo8,” “XMV,” and “R/Tio” screens.

- Settings on the MTX unit itself (the screen of the MTX5-D is shown)

Input to the MTX

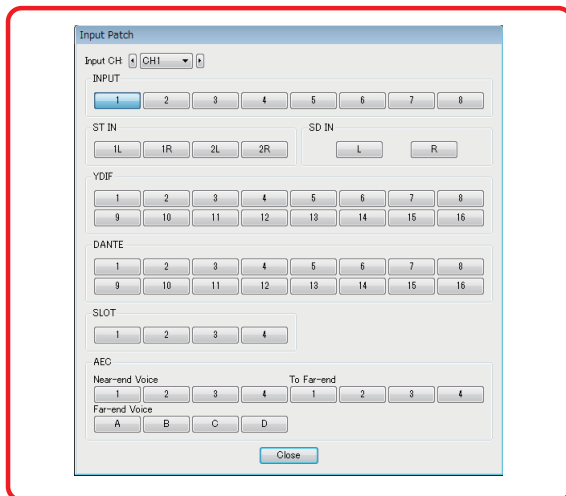

Output from the MTX

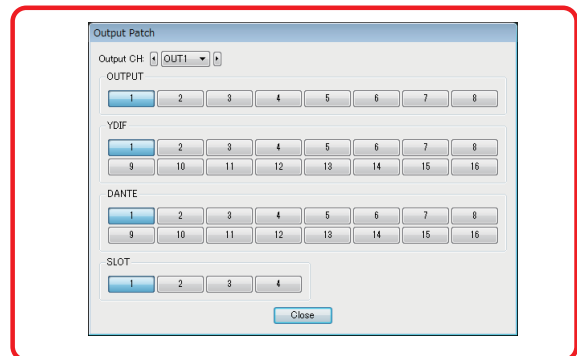

- Settings for external devices such as the XMV or EXi8

## YDIF

Transmission from an external device to YDIF

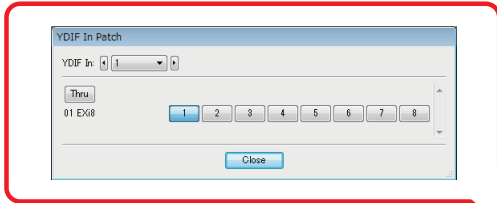

Transmission from the MTX to YDIF

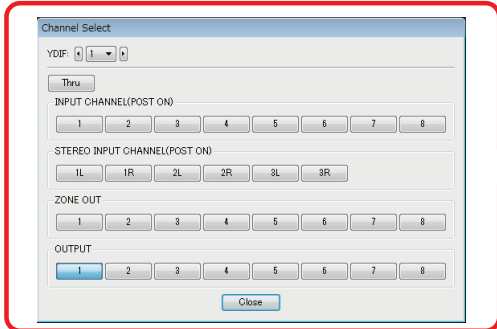

Transmission from YDIF to an external device

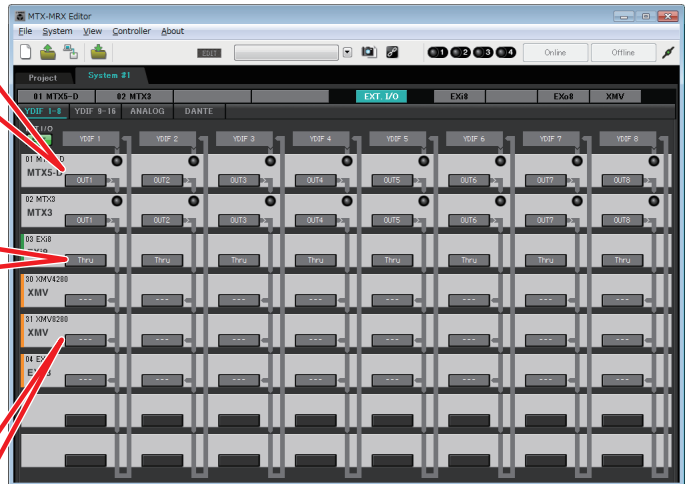
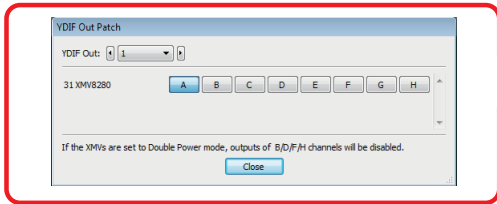

## Analog

Settings for the analog connectors of the XMV

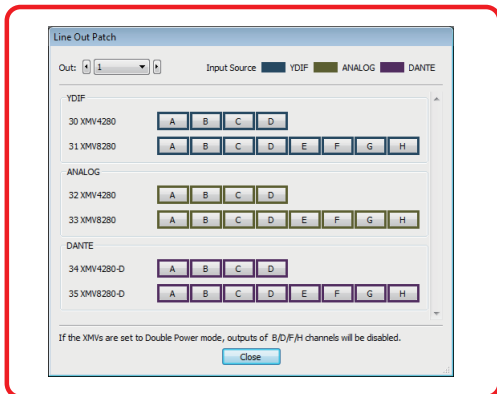

- Parameter editing screen

### MTX

Input channel parameter editing screen



Output channel parameter editing screen

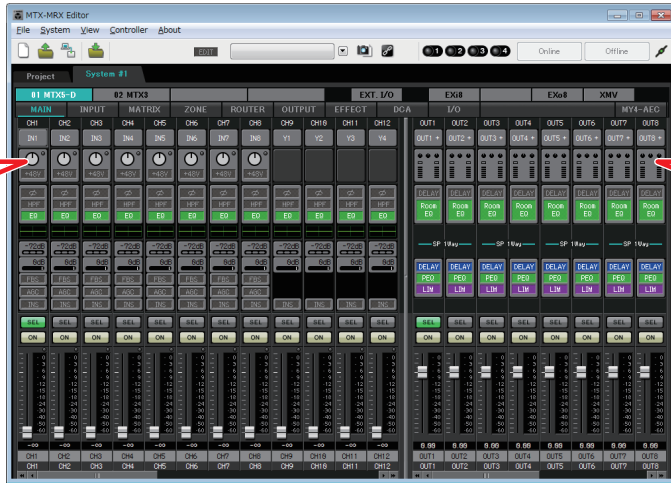
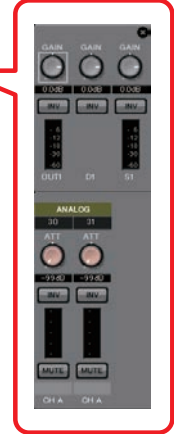

# Workflow

Start MTX-MRX Editor.

The “Startup” dialog box will appear.

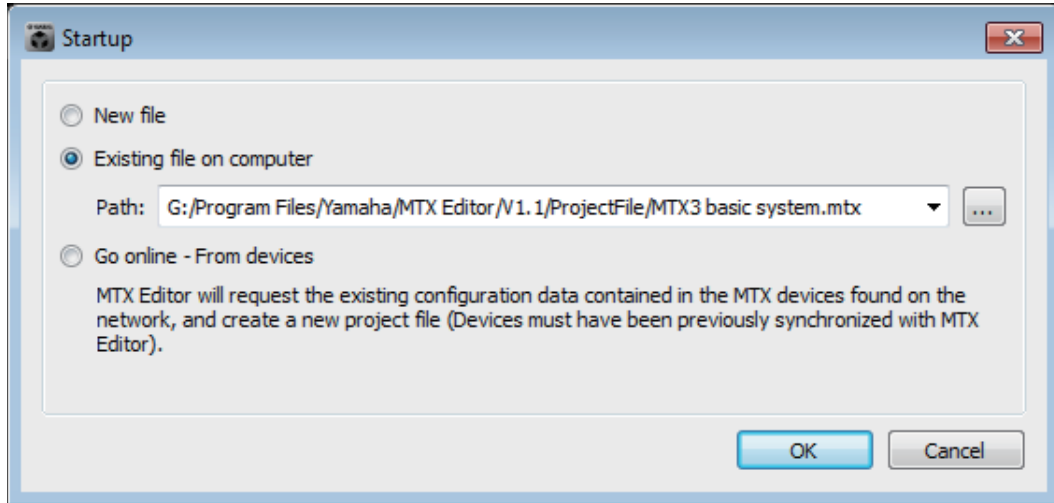

When you select [New file], the “Device Configuration Wizard” dialog box will appear.

**NOTE** When you install MTX-MRX Editor, a project file linked with the “MTX Setup Manual” and “MRX Setup Manual” is installed in the following folder.

- For a 32-bit OS

C:/Program Files/Yamaha/MTX-MRX Editor/V\*.\*/\*ProjectFile

- For a 64-bit OS

C:/Program Files(x86)/Yamaha/MTX-MRX Editor/V\*.\*/\*ProjectFile

\*.\* will be the version of the installed MTX-MRX Editor.

You can also select and use this file by selecting [Existing file on computer].



Follow the screens of the “Device Configuration Wizard” dialog box to specify the configuration of the MTX/MRX system.

For details about the “Device Configuration Wizard” dialog box when creating a new configuration, refer to the “MTX Setup Manual” or the “MRX Setup Manual.”

Specify the configuration of the MTX/MRX system as directed in the screens. The device configuration will be shown in the Project screen. You’ll be able to print a configuration diagram at the end of the wizard.

If you canceled the procedure before completing the “Device Configuration Wizard,” or if you want to change the configuration of the MTX/MRX system, click the [Device Config] button. The “Device Configuration Wizard” dialog box will appear once again.

Project screen

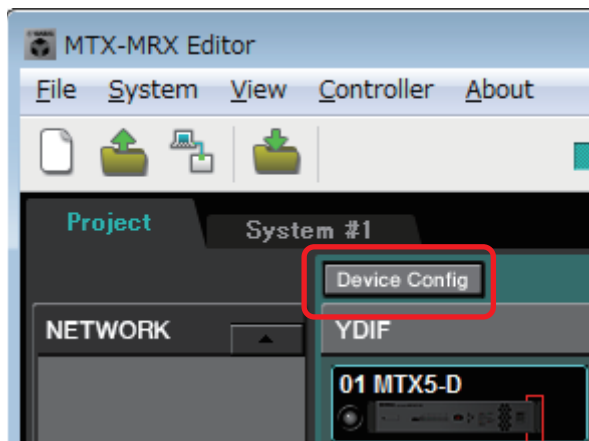

For details, refer to [Project screen](#).



### Change the functions of the MTX.

To change the functions of input ports and stereo input channels, use the “[MTX Configuration](#)” dialog box, which can be opened from the [System] menu.



### Specify the patching between the MTX/MRX and the peripheral devices.

You’ll make these settings in the “[EXT. I/O](#)” screen. To access the “EXT. I/O” screen, click the [EXT. I/O] button in the System screen.

For the MRX, only DANTE can be specified. For YDIF, make settings in the component editor of the “MRX Designer” window.

EXT. I/O screen

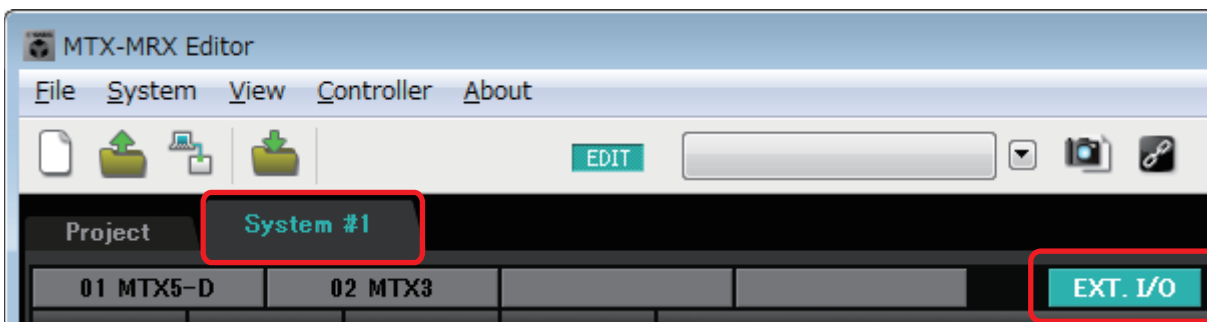

For the MTX, click the [MAIN] button in the System screen to access the “MAIN” screen.

For the MRX, click the [Open MRX Designer] button in the System screen to access the “MRX Designer” window.

MTX: MAIN screen



For details, refer to “[MAIN](#)” screen.

MRX: MRX Designer window

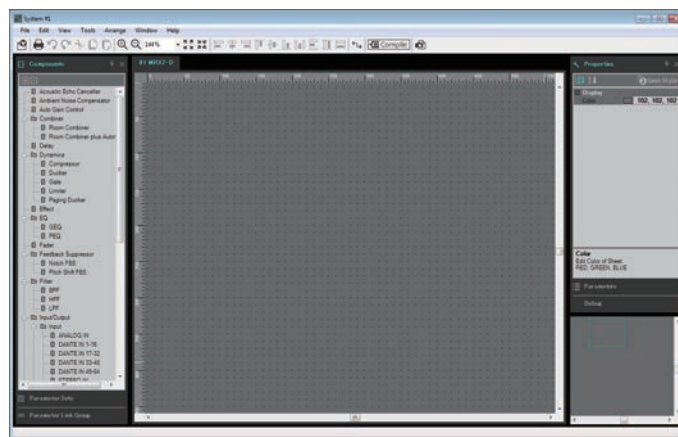

For details, refer to “[MRX Designer User Guide](#)”.

The subsequent workflow is explained using the MTX as an example.

For the MRX, make settings in the “MRX Designer” window, and then proceed to “[Store the preset](#).”



### Specify the MTX's input channel settings.

Use the “[Input Patch](#)” dialog box to assign ports to input channels. To open the “Input Patch” dialog box, click a port select button in the MAIN screen.

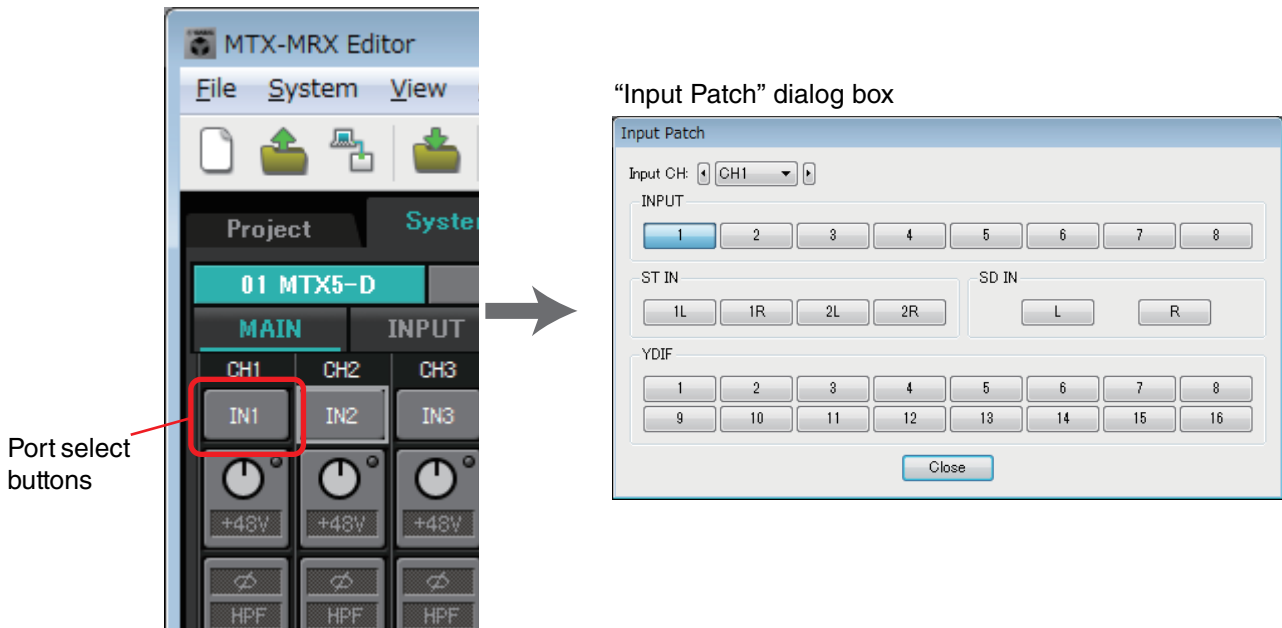

For details, refer to “[Input Patch](#)” dialog box.

In the same way, use the “[Output Patch](#)” dialog box to assign ports to output channels.



### Edit the component parameters.

To access each component editing screen, click the buttons indicated below.

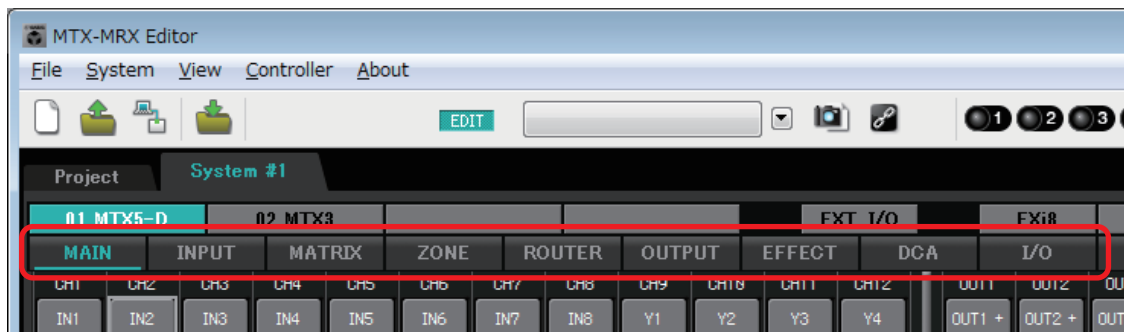

For details on each component, refer to the following screens.

“[INPUT](#)” screens

“[MATRIX](#)” screen

“[ZONE](#)” screen

“[ROUTER](#)” screen

“[OUTPUT](#)” screens

“[EFFECT](#)” screen

“[DCA](#)” screen

“[I/O](#)” screen



## Make DCP, Wireless DCP, MCP1, PGM1/PGX1, GPI, and Scheduler settings.

You'll make these settings in the following dialog boxes.

DCP settings: [“Digital Control Panel” dialog box](#)

(On the [Controller] menu, click [Digital Control Panel].)

Wireless DCP settings: [“Wireless DCP” dialog box](#)

(On the [Controller] menu, click [Wireless DCP].)

MCP1 settings: [“MCP1” dialog box](#)

(On the [Controller] menu, click [MCP1].)

PGM1/PGX1 settings: In the [“ZONE” screen](#), [PAGING] and the [“PGM1/PGX1” dialog box](#)

(On the [Controller] menu, click [PGM1/PGX1].)

GPI settings: [“GPI” dialog box](#) or [“GPI Calibration” dialog box](#)

(On the [System] menu, click [GPI] or [GPI Calibration].)

Schedule settings: [“Scheduler” dialog box](#)

(On the [System] menu, click [Scheduler].)



## Store the preset.

You'll use the [“Preset” dialog box](#) to store the preset. To open the “Preset” dialog box, click the preset button.

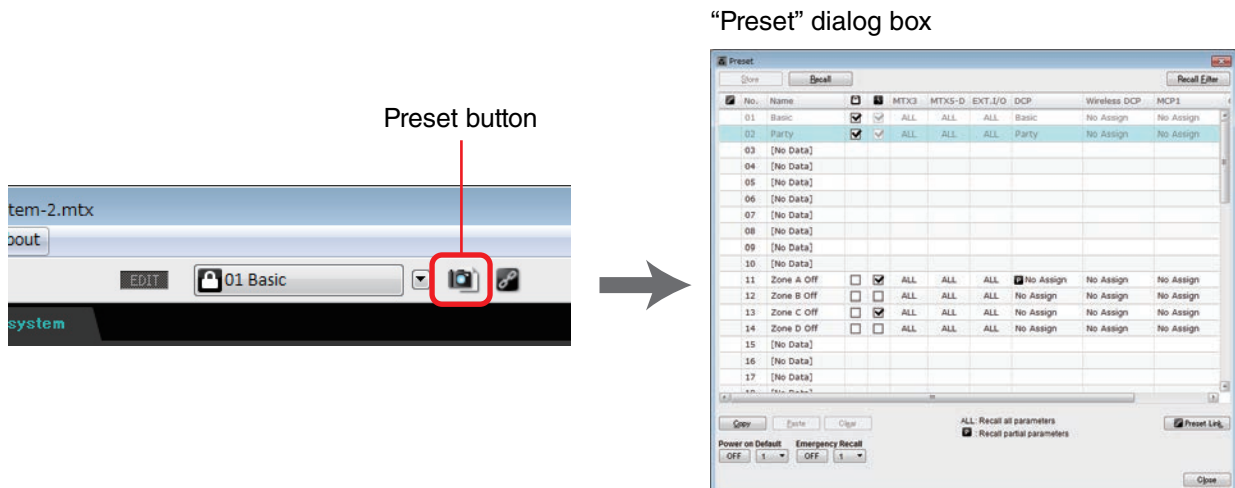

For details on the DCP library, Wireless DCP library, MCP1 library, and audio file settings that are recalled at the same time as a preset, refer to [“Preset” dialog box](#).



## Connect your devices as shown in the configuration diagram you printed.

Turn off the power of each device, and set the UNIT ID on the rear panel of the MTX/MRX, XMV, EXi8/EXo8, and PGM1 units. For the MCP1, turn on the power before setting the UNIT ID.

**NOTE** You can also print the configuration diagram by clicking [\[Print Configuration Diagram\]](#) on the [\[File\]](#) menu.

First make sure that DIP switch 6 (IP SETTING) on the unit's rear panel is set to [UNIT ID]. If it is set to [PC], change it to [UNIT ID] and then restart the device.

Use the rear panel [UNIT ID] rotary switch and DIP switches to set the UNIT ID of each device. In MTX-MRX Editor, the UNIT ID is shown as a hexadecimal number. Use the DIP switches (switches 1–2 on the MTX/MRX and EXi8/EXo8, switches 1–3 on PGM1 and YDIF-equipped models of XMV) to specify the upper digit, and use the [UNIT ID] rotary switch to specify the lower digit. On Dante-equipped models of XMV, use the [UNIT ID] rotary switch [HIGH] to specify the upper digit, and use [LOW] to specify the lower digit.

For details on the R series (AD/DA) or the Tio1608-D, refer to their respective owner's manuals.

Do not set the UNIT ID to 00.

**Example setting**) Setting the UNIT ID to [0A] on YDIF-equipped models of XMV

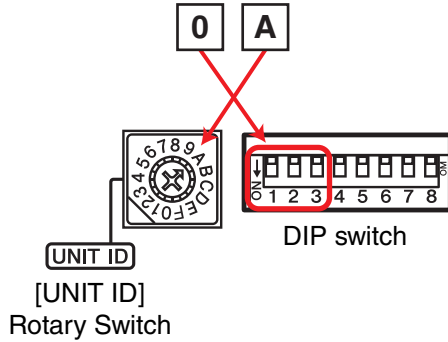

Use the DIP switch combinations shown below to specify the upper digit of the UNIT ID.

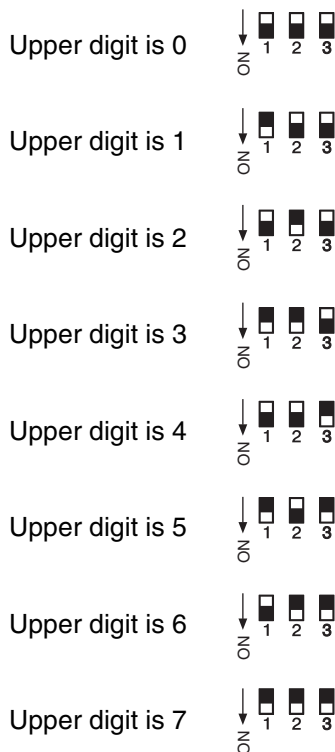

**NOTE** If you want to use a DHCP server or operate the device with a fixed IP address, refer to “IP Address” dialog box. To open the “Set IP Address” dialog box, use the “Device Information” dialog box which you can access from the [System] menu.



### Connect the devices and your computer as shown in the configuration diagram.

Connect the device to the computer using its [Dante] connector for a Dante-equipped unit or its NETWORK connector for an MCP1 and YDIF-equipped unit. Normally you will connect the devices to the computer via a network switch. Only in the case of Dante-equipped models when using a daisy-chain connection, you will connect the units to the computer in a daisy-chain. If there is only one MTX/MRX unit, you can also connect the computer directly to the MTX/MRX. If connecting the MCP1 and PGM1, you will need an IEEE802.3af compliant PoE network switch or PoE injector. For details, refer to the respective installation manual.

NETWORK connector of the MTX3

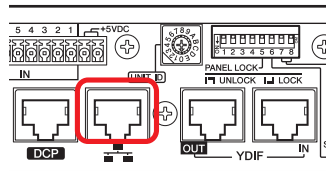

NETWORK connector of the EXi8/EXo8

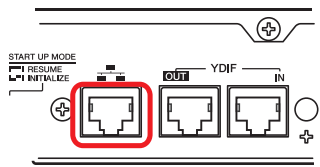

NETWORK connector of a YDIF-equipped model of XMV

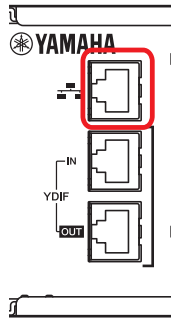

[Dante] connector of a Dante-equipped model of XMV

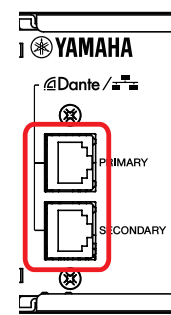

[Dante] connector of the MTX5-D/MRX7-D

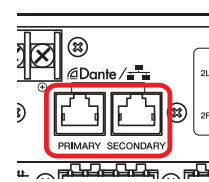

Turn on the power of the device.



In the MCP1's settings page, verify that IP Setting is set to [UNIT ID], and set the UNIT ID.



Select the network card and specify the IP address of the computer.

To select the network card, use the “[Network Setup](#)” dialog box which you can access from the [System] menu. Set the network card's IP address to 192.168.0.x (x is a number other than 0, 255, or the unit's UNIT ID) and the subnet mask to 255.255.255.0. The IP address setting for the network card is made in Control Panel “Network Connections.” You can access “Network Connections” by clicking the [Open Network Connections] button in the “[Network Setup](#)” dialog box.

When connections have been established between the computer and the devices, the device icons shown in the Project screen will change.



Connections with the devices has succeeded

### Verify that the firmware versions of the devices are compatible with MTX-MRX Editor.

For details, refer to the “[Device Information](#)” dialog box which you can access from the [System] menu.

For information about firmware compatibility with MTX-MRX Editor, refer to the Yamaha Pro Audio website.

<http://www.yamahaproaudio.com/japan/ja/>



### Synchronize your computer and the devices (put them in the online state).

Click the [Online] button in the toolbar to open the “[Synchronization](#)” dialog box, check “To Device”, and click the [OK] button.

When the dialog box indication has switched, select the check box of the system that you want to place online, and click the [Online] button.

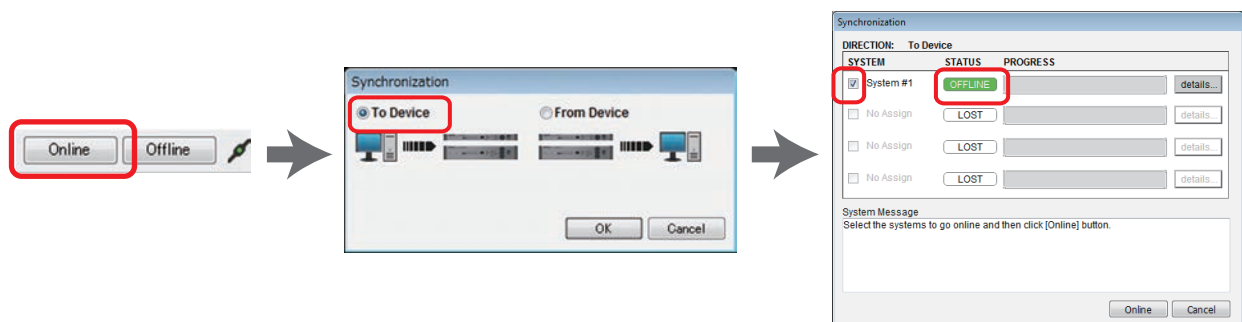

The contents of the MTR-MRX Editor’s settings are sent to each device. In the online state, the indicator will light blue as shown below.



- NOTE**
- When online, the computer’s time will be sent to each device.
  - The Daylight Saving Time setting will reflect the “Date and Time” settings of the computer that was used to first create the applicable project file. If you want to change the Daylight Saving Time settings of a project file that was created on a computer for which Daylight Saving Time was not enabled, or a computer with a different time zone setting, open the “[Daylight Saving Time](#)” dialog box from the [System] menu and change the settings.



## Edit the MTX's ports and the XMV's parameters

If you assigned channels of an external device or ports of an MTX unit to channels when making internal MTX patch settings as described above, you can click the parameter recall button of that port or external device to open an edit screen for those parameters.

For details, refer to “[MAIN](#)” screen if you're using the MTX. If you're using the MRX, refer to the “MRX Designer User Guide.”



### Save the project file.

On the [File] menu, click [Save] or [Save As] to save the project file.

If you want to apply security settings to the file, you can specify a PIN code in the “[Security Settings](#)” dialog box which you can open from the [File] menu.

# About the screens

MTX-MRX Editor consists mainly of the Project screen and the System screen.

## □ Project screen

In this screen you can manage the MTX/MRX system. You can check the status of the MTX and XMV units, and make device-related settings. You can also check devices that have generated an alert.

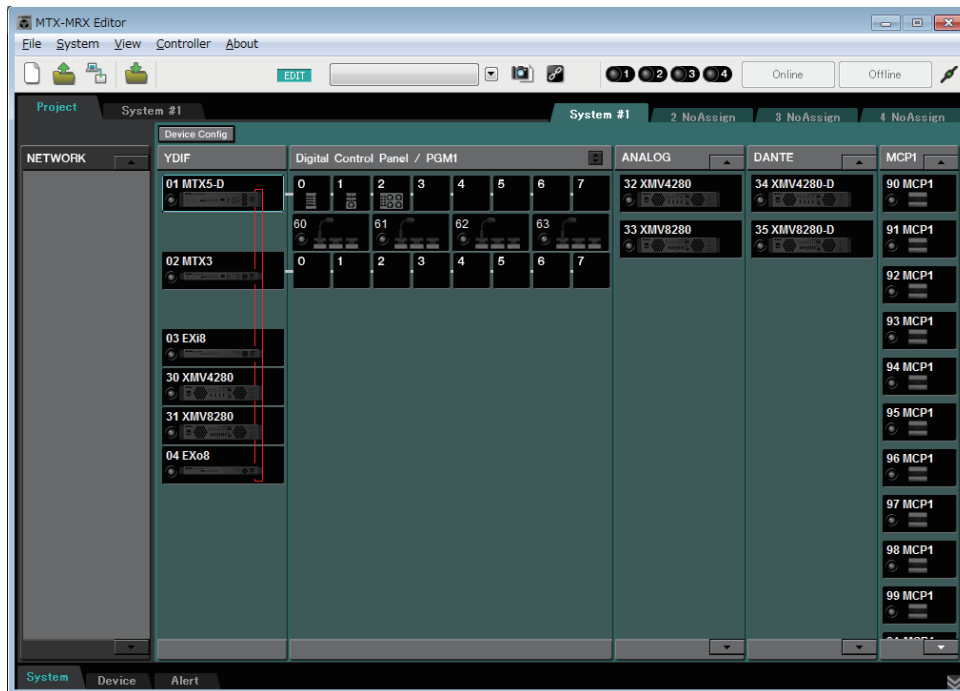

## □ System screen

In this screen you can make channel, matrix, and effect settings.



# Moving between screens

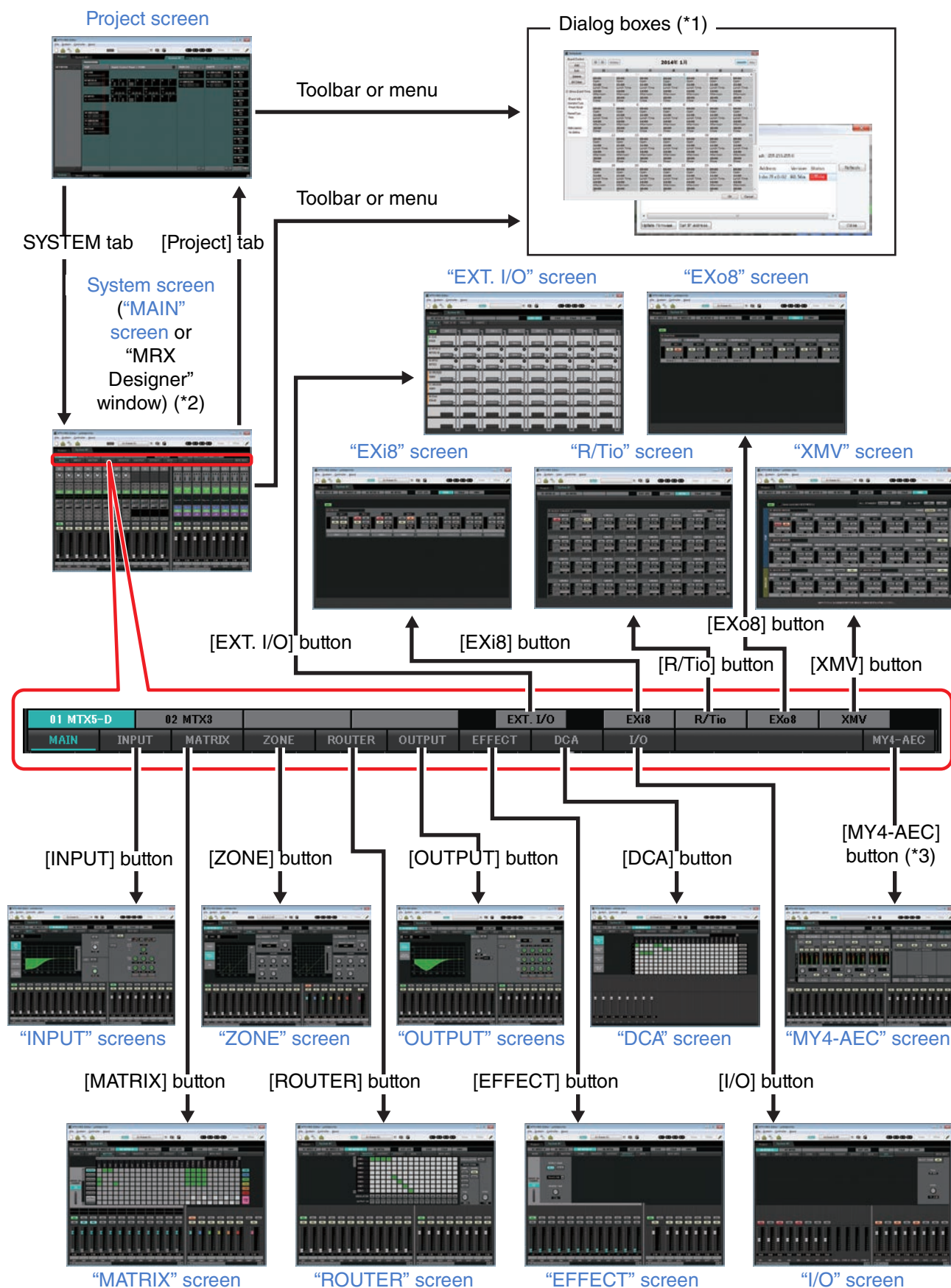

(\*1) The “Device Configuration Wizard” dialog box can be opened only from the Project screen.  
 (\*2) Not shown if the MRX is not selected in the “Device Configuration Wizard” dialog box. For details about this screen, refer to “MRX Designer User Guide.”  
 (\*3) Not shown if the MY4-AEC is not selected for the MTX5-D in the “Device Configuration Wizard” dialog box.

# Chapter 2. Menu bar and tool buttons

This chapter provides an overview of the menu bar and the tool buttons. For details on the various dialog boxes, see the linked references.

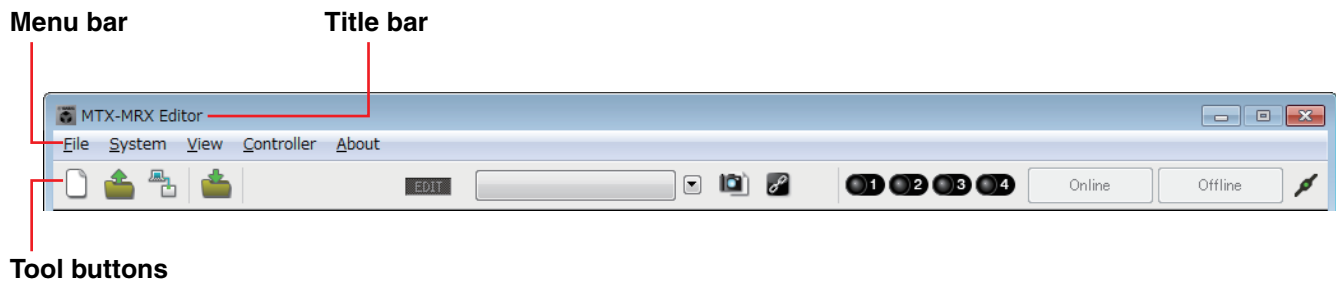

## Title bar

This will indicate “MTX-MRX Editor.”

The name of the currently open project file is shown at the right of this. If you have opened a new project file or if the project file has never been saved, nothing will be shown here.

## Menu bar

The commands that can be executed by MTX-MRX Editor can be found here, grouped by category. Click here to see a list of commands.

Menu	Command	Summary	Dialog box that appears
<b>[File]</b>	[New]	Creates a new project file. If you are currently editing a project file, a confirmation message will appear. This command is not available while online.	“Device Configuration Wizard” dialog box
	[Open]	Opens a saved project file. If you are currently editing a project file, a confirmation message will appear. This command is not available while online.	“Open File” dialog box
	[Go Online – From Devices]	Loads the settings of the MTX/MRX system into MTX-MRX Editor. You can use this command if you have lost the setup file of the MTX/MRX system. If you are currently editing a project file, a confirmation message will appear. This command is not available while online.	“Go online – From devices” dialog box
	[Save]	Saves the project file (overwriting the previous version of the file). The first time you save, the “Save File” dialog box will appear; specify a name for the file and save it.	–
	[Save As]	Saves the project file as a different file. When you choose this command, the “Save File” dialog box will appear.	“Save File” dialog box
	[Security]	Specifies security settings to prevent another user from making and saving changes to the system. These settings are saved in the project file.	“Security Settings” dialog box
	[Project Information]	Allows you to include a memo in the project file to record property information or contact information.	“Project Information” dialog box
	[Print Configuration Diagram]	Displays a diagram that shows how devices such as the MTX/MRX, XMV, and DCP are connected. The configuration diagram can be printed.	“Configuration Diagram” dialog box
	[PGM1 Label Creator]	Starts the “PGM1 Label Creator” application to create labels for the PGM1/PGX1.	“PGM1 Label Creator” application
	[Recently Opened Files]	Lists up to five most recently used project files, allowing you to open them. This command is not available while online.	–
[Exit]	Exits MTX-MRX Editor. If the project file has been edited, a confirmation message will appear. This command is not available while online.	–	

Menu	Command	Summary	Dialog box that appears
<b>[System]</b>	[Network Setup]	Selects the computer's network adapter that will be used to communicate with the MTX/MRX. You can also change the IP address of the network adapter.	"Network Setup" dialog box
	[Device Information]	Lists the devices on the network, allowing you to update their firmware and change their IP address.	"Device Information" dialog box
	Match Device by IP Address	Makes settings for devices that are on a different subnet than the computer.	"Match Device by IP Address" dialog box
	[Install Speech Privacy File]	Transmits to the MRX a file used when using the "Speech Privacy" component on the MRX. For details, refer to "MRX Designer User Guide."	"Install Speech Privacy File" dialog box
	[MTX Configuration]	Here you can specify input/output settings for each device, such as MTX input ports, output channels, and matrix buses. This command is not available in the Project screen.	"MTX Configuration" dialog box
	[Dante Information]	Indicates the Dante settings and firmware version. Here you can also make settings for bit rate and latency.	"Dante Information" dialog box
	[Word Clock]	Specify the project's word clock master and word clock settings.	"Word Clock" dialog box
	[Clock]	Regardless of the online/offline state, the time and date will be updated for all devices connected to the same network.	"Clock" dialog box
	[Daylight Saving Time]	Regardless of the online/offline state, the daylight saving time setting is specified for all devices connected to the same network.	"Daylight Saving Time" dialog box
	[Scheduler]	Switches presets or plays back a song or sound effect from an SD memory card at a previously specified date and time. Each such setting is called an "Event." You can make event settings in the "Scheduler" dialog box.	"Scheduler" dialog box
	[GPI Calibration]	Calibrates the input voltage detection range for the [GPI] connector of the MTX/MRX unit. (Available only when online.)	"GPI Calibration" dialog box
	[GPI]	Makes GPI input/output settings.	"GPI" dialog box
[Remote Control]	Makes settings for the [RS-232C] connector.	"Remote Control" dialog box	
<b>View</b>	[Large Scale View]	Sets MRX Designer's component editor and MTX-MRX Editor to a vertical and horizontal display magnification of 200%.	–
<b>[Controller]</b>	[Digital Control Panel]	Makes settings for the digital control panel (DCP).	"Digital Control Panel" dialog box
	[Wireless DCP]	Makes settings for the "Wireless DCP" iOS application. Except for templates, the items that can be set are the same as for "Digital Control Panel."	"Wireless DCP" dialog box
	[MCP1]	Makes MCP1 settings.	"MCP1" dialog box
	[PGM1/PGX1]	Makes PGM1/PGX1 settings.	"PGM1/PGX1" dialog box

Menu	Command	Summary	Dialog box that appears
<b>[About]</b>	[Shortcut Keys]	Shows a list of shortcut keys.	"Shortcut Keys" window
	[Operation Manual]	Displays basic operations.	"Operation Manual" window
	[About MTX-MRX Editor]	Displays details such as the software version of MTX-MRX Editor.	-

# Tool buttons

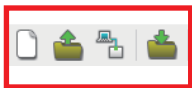

File-related tools

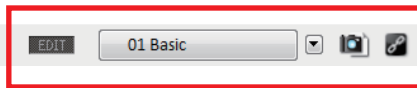



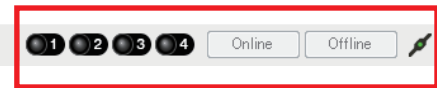



Preset-related tools



Synchronization-related tools

Related tools	Buttons etc.	Summary	Dialog box that appears
File	[New]	Creates a new project file. If you are currently editing a project file, a confirmation message will appear. This button is not available while online.	“Device Configuration Wizard” dialog box
	[Open]	Opens a saved project file. If you are currently editing a project file, a confirmation message will appear. This button is not available while online.	“Open File” dialog box
	[Go Online – From Devices]	Loads the settings of the currently operating MTX/MRX system into MTX-MRX Editor. You can use this command if you have lost the setup file of the MTX/MRX system. If you are currently editing a project file, a confirmation message will appear. This button is not available while online.	“Go online – From devices” dialog box
	[Save]	Saves the project file (overwriting the previous version of the file). The first time you save, the “Save File” dialog box will appear; specify a name for the file and save it.	–
Preset	[EDIT] indicator	This indicator will light if you edit a parameter or setting. In this case, store the preset as necessary.	–
	Preset select box	The stored presets will be displayed as shown below. (Empty presets are not shown.) The preset you select here will be recalled. You can overwrite-store by clicking the name of a stored preset. When you click the ▼ at right, a pulldown menu appears, allowing you to recall the selected preset.  Preset name Preset number Shown only if recall filter is specified A chain icon is shown if preset recall is linked. A lock icon is shown if the preset is locked.	–
	[Preset]	Allows you to make preset-related settings.	“Preset” dialog box
	[Preset Link]	Allows you to specify the preset number that will be linked when preset recall is linked between MTX/MRX systems.	“Preset Link” dialog box

Related tools	Buttons etc.	Summary	Dialog box that appears
Synchronization	 Online indicator	This will light if the devices and the computer are online. The color of the indicator will change according to the status. The indicator is shown for each MTX/MRX system. Blue .....when all devices assigned in the MTX/MRX system are online. Yellow ....when at least one of the devices assigned in the MTX/MRX system is offline Unlit .....when all devices are offline.	-
	 [Online]	When you click this, the “Synchronization” dialog box will appear, allowing you to choose the direction of synchronization. If you click this when online, devices that are offline will be re-detected, and synchronization will begin. Nothing will happen for devices that are already online. <b>NOTE</b> <i>If an MTX/MRX that has been assigned in the “Device Configuration Wizard” dialog box is not actually connected to the network, the [Online] button will not be available.</i>	“Synchronization” dialog box
	 [Offline]	When you click this, a dialog box will appear, allowing you to choose which MTX/MRX system will be taken offline. <b>NOTE</b> <i>If an MTX/MRX that has been assigned in the “Device Configuration Wizard” dialog box is not actually connected to the network, the [Offline] button will not be available.</i>	
	 [Connection]	Switches the status of the connection between MTX-MRX Editor and the network. Even in the offline state, if this status is connected, MTX-MRX Editor will send data to the network, for example to search for devices. Set this to the unconnected status if you don't want unnecessary data to be transmitted, for example if you're connected to an office LAN.  Connected.  Unconnected.	

# Chapter 3. Project screen

In this screen you can manage projects. When MTX-MRX Editor starts up, this screen will appear first. Use the tabs to switch between the Project screen and the System screen.

**Network devices**                      **MTX/MRX system**                      **System selection tabs**

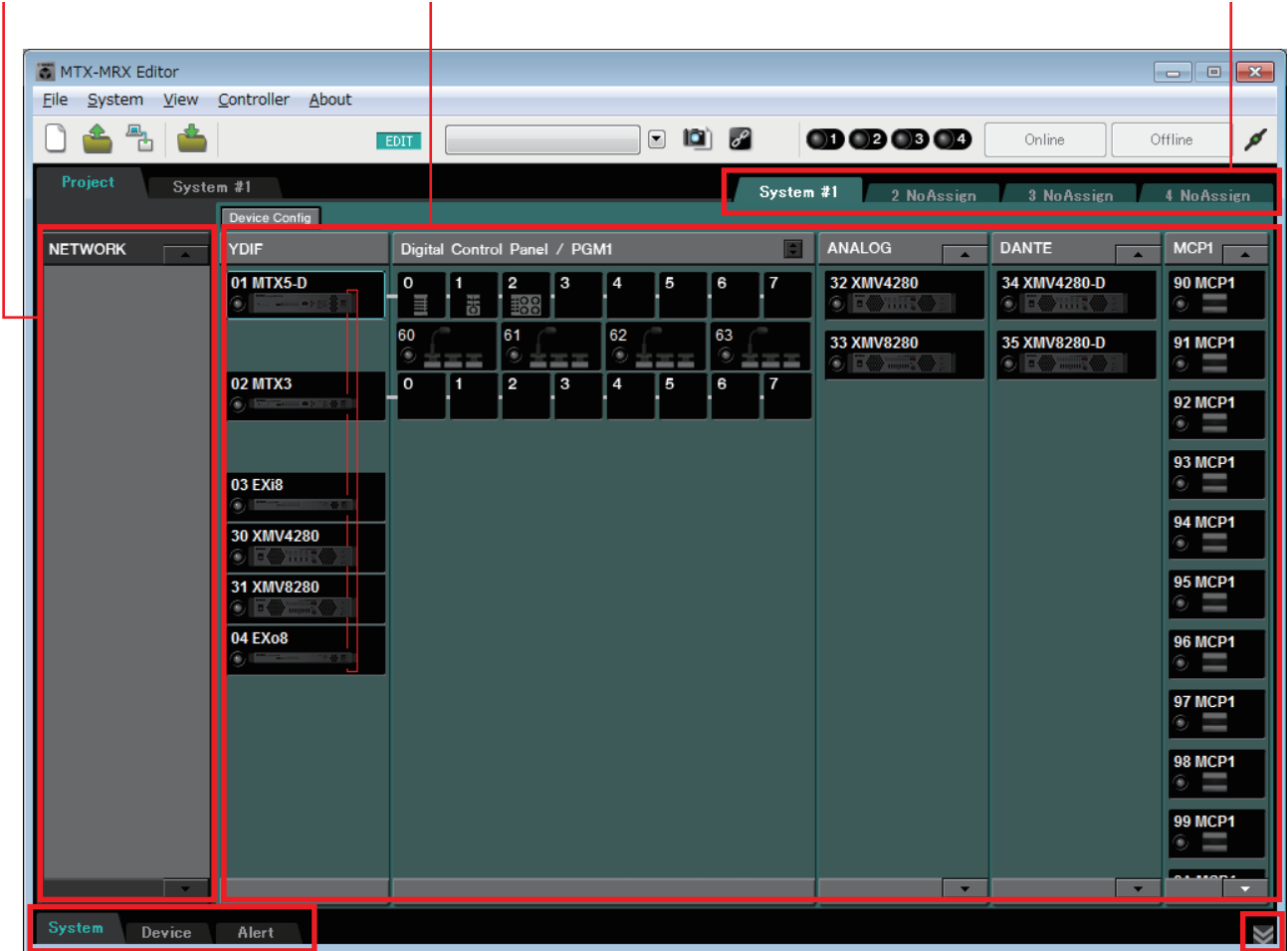

[System] tab, [Device] tab, [Alert] tab

HIDE/SHOW button

## System selection tabs

Use these to select the MTX/MRX system that will be controlled by MTX-MRX Editor. If you want to construct a new MTX/MRX system, click the “No Assign” tab, then click the [Device Config] button and specify the configuration of the MTX/MRX system.



## HIDE/SHOW button

 Hides/shows the [System] tab, [Device] tab, and [Alert] tab.

# Network devices

This lists the devices existing on the same network as the computer. (Devices assigned to the MTX/MRX system are not shown.)

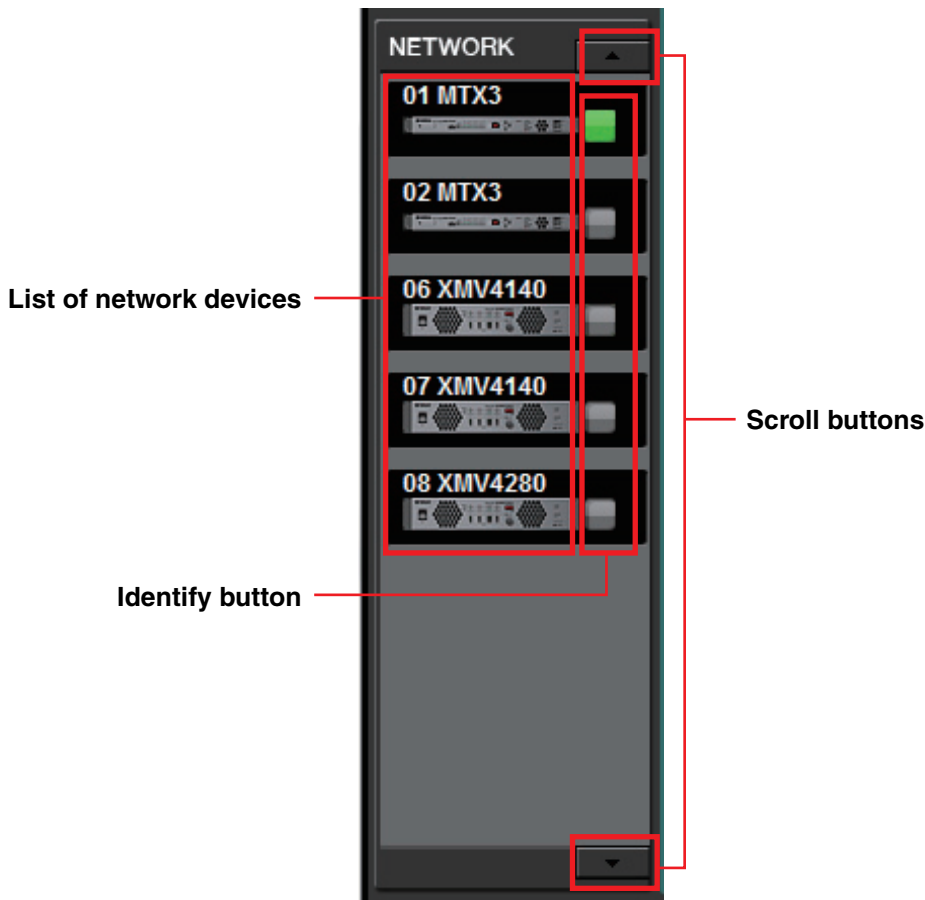

## List of network devices

These are the devices existing on the same network. The UNIT ID, device name, and a graphic of the device are shown.

## Identify button

When you click this, the indicator of the corresponding device will flash for approximately five seconds, allowing you to identify the device.

## Scroll buttons

Use these to scroll the display up or down.

# MTX/MRX system

[Device Config] button

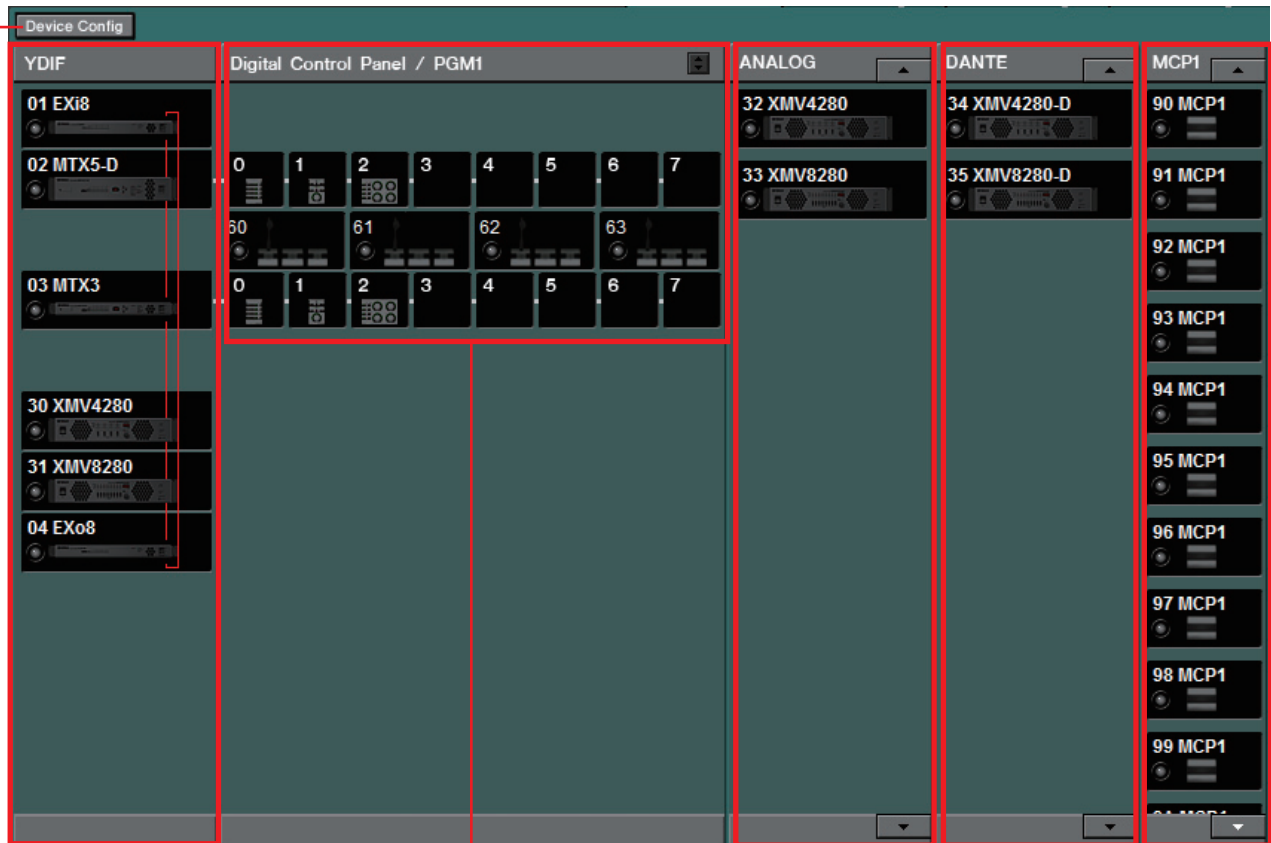

YDIF-  
connected  
devices

Digital control panel  
and PGM1/PGX1

Analog-  
connected  
devices

DANTE-  
connected  
devices

MCP1

## [Device Config] button

When you click this, the “[Device Configuration Wizard](#)” dialog box will appear.

## □ “Device Configuration Wizard” dialog box

In this dialog box, you’ll use the wizard to create or edit the configuration (structure) of the MTX/MRX system. You can easily specify or edit the type of devices and the order in which they are connected.

Here we will explain the dialog box that appears when you click the [Device Config] button in the Project screen. For details on how the wizard will proceed if you select the [New] option button, refer to “MTX Setup Manual” or “MRX Setup Manual.”

### 1. When you click the [Device Config] button, the “Device Configuration Wizard” dialog box will appear.

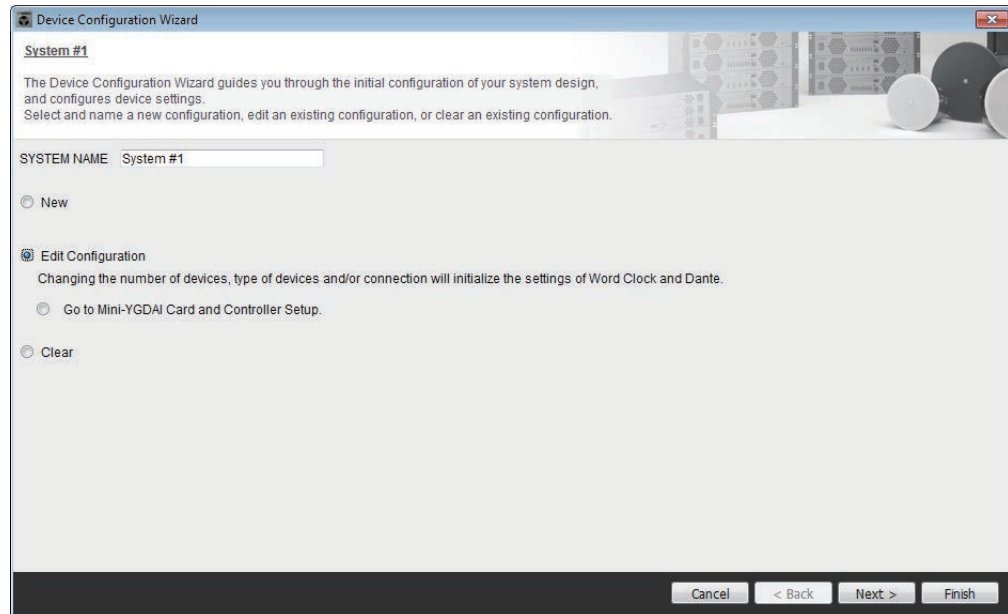

Choose whether you want to create a new MTX/MRX system or to edit an existing one.

- **[New] option button**  
A new configuration will be created.  
Enter the desired system name in the [SYSTEM NAME] input box.
- **[Edit Configuration] option button**  
An existing configuration will be edited. If no devices have been assigned, this option will be unavailable.  
Select the radio button located below and click the [Next>] button to proceed to an editing screen for the Mini-YGDAI card or controller.
- **[Clear] option button**  
The configuration will be cleared. If no devices have been assigned, this option will be unavailable.
- **[Cancel] button**  
Cancels the operation and exits the wizard.
- **[< Back] button**  
This button will be dimmed and unavailable.
- **[Next >] button**  
Proceeds to the next screen.

- **[Finish] button**

This can be selected if you have selected something other than the [New] option button. When you click this, a confirmation message will appear; click the [Yes] button to clear the data and end the wizard. If you click the [No] button, the operation will be cancelled, and you will return to the previous dialog box.

**2. From the devices that have already been assigned, delete any that you do not need. (Only if you selected [Edit Configuration] in step 1.)**

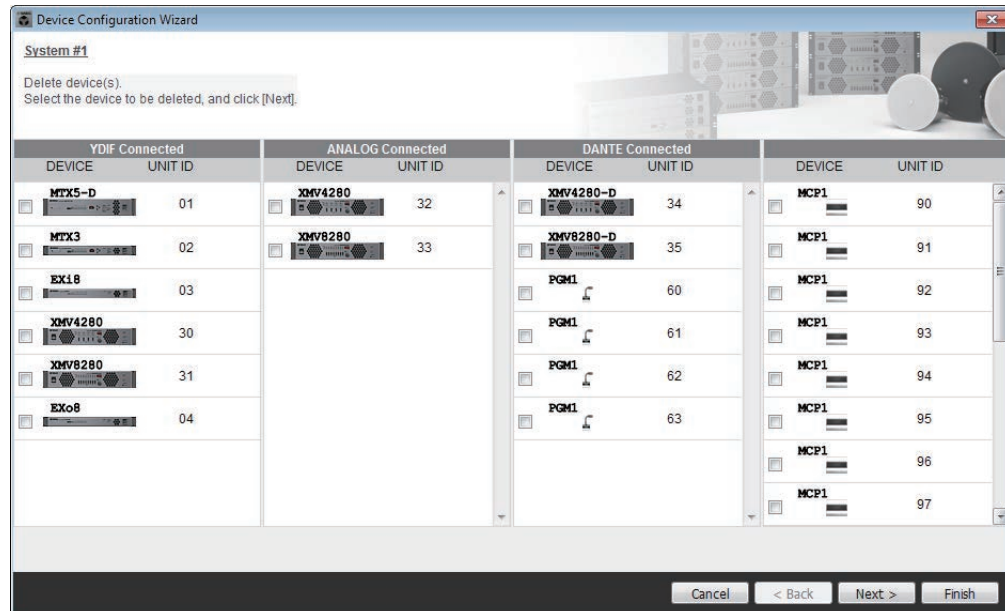

Delete unneeded devices from those that have already been assigned. Select the check box located at the left of each device that you want to delete.

- **[Cancel] button**

Cancels the operation and exits the wizard.

- **[< Back] button**

This button will be dimmed and unavailable.

- **[Next >] button**

Applies the changes and proceeds to the next screen.

When you select devices and click the [Next >] button, a confirmation message will appear. If you click the [Yes] button, the changes will be applied and you will proceed to the next screen. If you click the [No] button, the operation will be cancelled, and you will return to the previous dialog box.

- **[Finish] button**

When you select devices and click the [Finish] button, a confirmation message will appear. If you click the [Yes] button, the changes will be applied and the wizard will close. If you click the [No] button, the operation will be cancelled, and you will return to the previous dialog box.

If you click the [Finish >] button without selecting a device, a message will ask whether you want to view a configuration diagram. If you click the [Yes] button, the configuration diagram (“Configuration Diagram” dialog box) will appear (→step 10). If you click the [No] button, the wizard will close without displaying the configuration diagram.

### 3. Specify the type and number of devices that will be assigned to the MTX/MRX system.

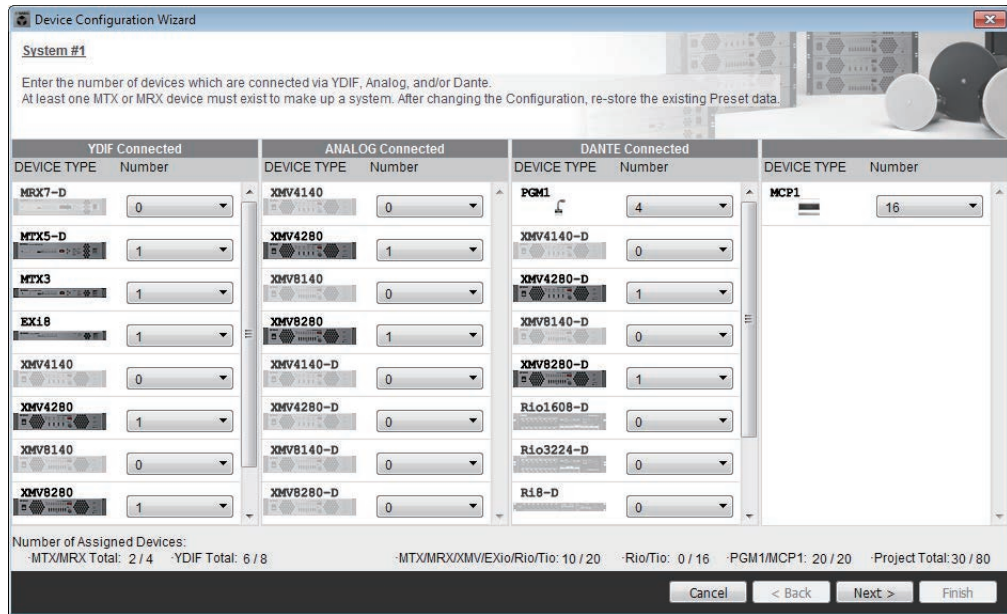

Determine the number of devices that will be connected via cable, other than digital control panels.

If you selected [Edit Configuration] in the first screen of the wizard, the currently-assigned number of devices is shown. In this case, it is not possible to change the number of units to less than this number or to greater than [Connection requirements for an MTX/MRX system](#).

Devices whose number of units is set to 0 will be dimmed and unavailable.

**NOTE** On the Tio1608-D, the UNIT ID range is narrower. When using the Tio1608-D, avoid using UNIT ID settings 01–0C for other devices in the next screen.

- **[Number] box**  
Specifies the number of devices.
- **[Cancel] button**  
Cancels the operation and exits the wizard.
- **[< Back] button**  
This button will be dimmed and unavailable.
- **[Next >] button**  
Applies the changes and proceeds to the next screen.
- **[Finish] button**  
This button will be dimmed and unavailable.

#### 4. Specify the UNIT ID of each device.

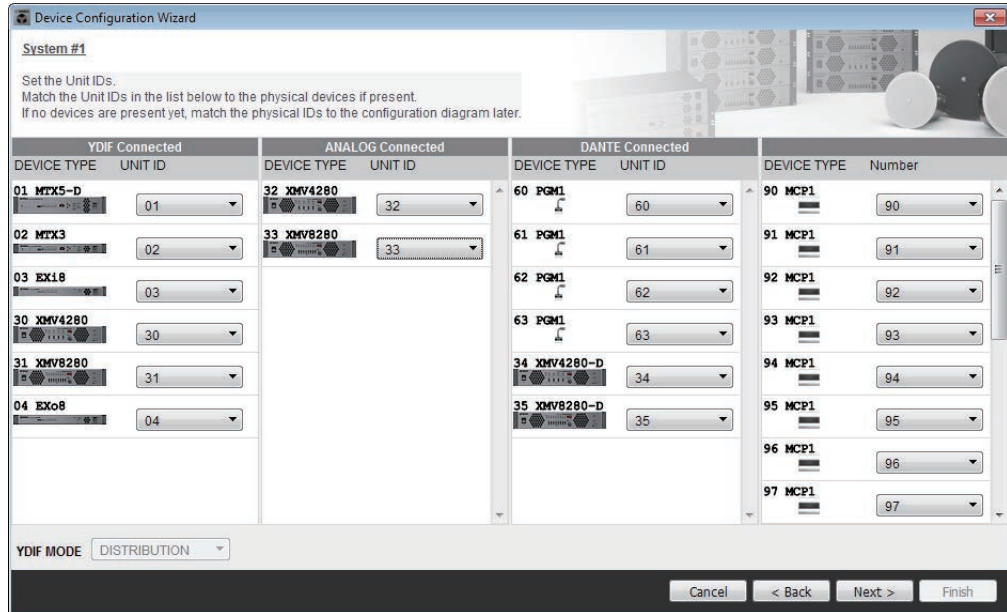

Specify the UNIT ID of each assigned device. Set the UNIT ID so that there is no conflict between devices.

If you selected [New] in the first screen of the wizard, the devices will be numbered automatically starting from the lowest UNIT ID. If you selected [Edit Configuration], the currently-specified UNIT ID will be shown. In either case you are free to make changes.

- **[UNIT ID] box**

Specify the UNIT ID of the device.

When you click the [UNIT ID] box, the model name of each device of the same type existing on the network is shown beside its UNIT ID. For devices that do not exist on the network, only the UNIT ID is shown.

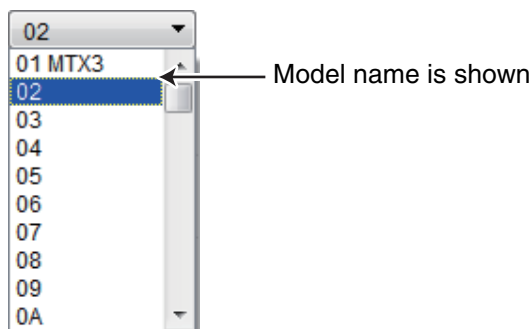

- **[YDIF MODE]**

Select either [CASCADE] or [DISTRIBUTION] as the connection mode for YDIF devices.

If there are any YDIF-connected devices other than the MTX, [DISTRIBUTION] will be selected automatically, and cannot be changed. If there is a single MTX unit, or if an MRX unit is part of the MTX/MRX system, this will be dimmed and cannot be changed.

- **[Cancel] button**

Cancels the operation and exits the wizard.

- **[< Back] button**

Returns to the previous screen.

- **[Next >] button**  
Applies the changes and proceeds to the next screen.
- **[Finish] button**  
This button will be dimmed and unavailable.

**5. View a configuration diagram that shows the connections necessary for control via MTX-MRX Editor.**

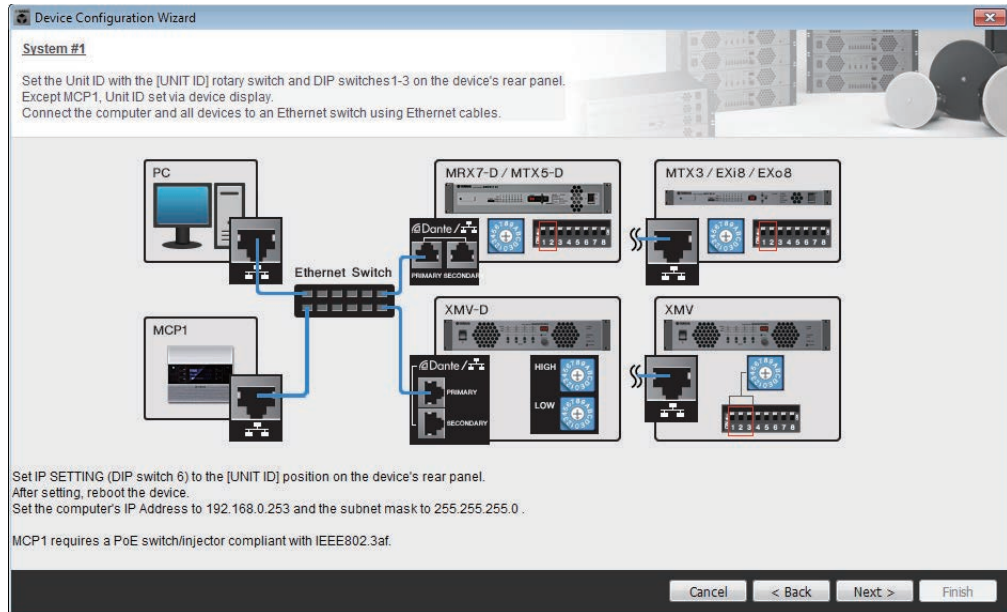

Make settings for the device as directed by the dialog box.

- **[Cancel] button**  
Cancels the operation and exits the wizard.
- **[< Back] button**  
Returns to the previous screen.
- **[Next >] button**  
Proceeds to the next screen.
- **[Finish] button**  
This button will be dimmed and unavailable.

## 6. Specify the order of the YDIF-connected devices.

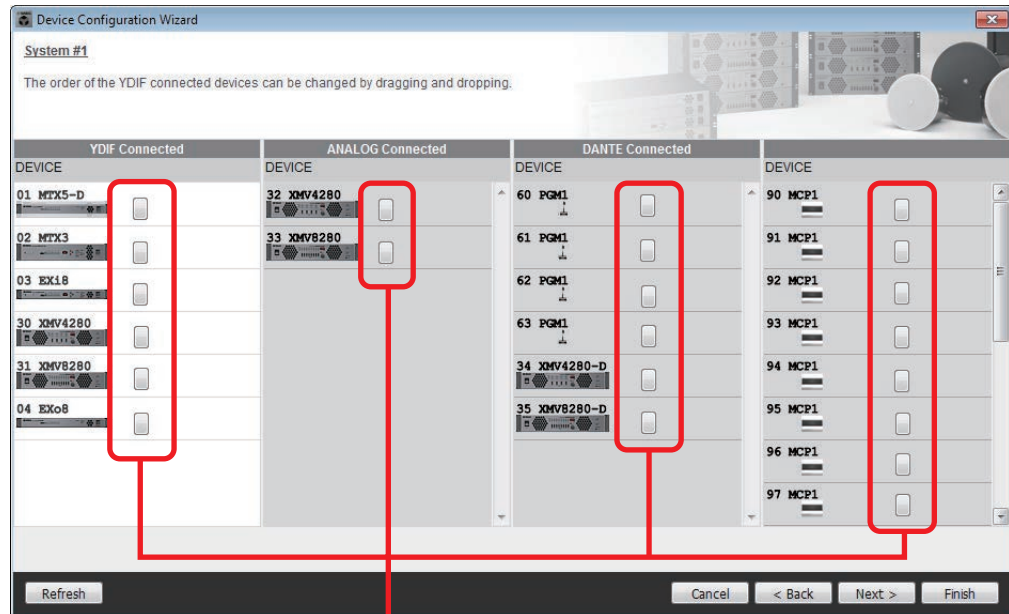

Identify button

You can drag and drop to change the connection order of the YDIF-connected devices.

- **[Identify] button**

When you click this, the indicator of the corresponding device will flash for approximately five seconds, allowing you to identify the device.

This is not shown if no device is connected.

- **[Refresh] button**

Searches again for devices on the network. Newly-connected devices and deleted devices will be re-detected.

- **[Cancel] button**

Cancels the operation and exits the wizard.

- **[< Back] button**

Returns to the previous screen.

- **[Next >] button**

Proceeds to the next screen.

- **[Finish] button**

Applies the changes and closes the wizard. A confirmation message will ask whether you want to view a configuration diagram. If you click the [Yes] button, the configuration diagram (“Configuration Diagram” dialog box) will appear (→[step 10](#)). If you click the [No] button, the wizard will close without displaying the configuration diagram.

**7. Specify the number of PGX1 units, and associate MTX5-D/MRX7-D and PGM1 units.  
(If PGM1 is set to other than 0 in step 3.)**

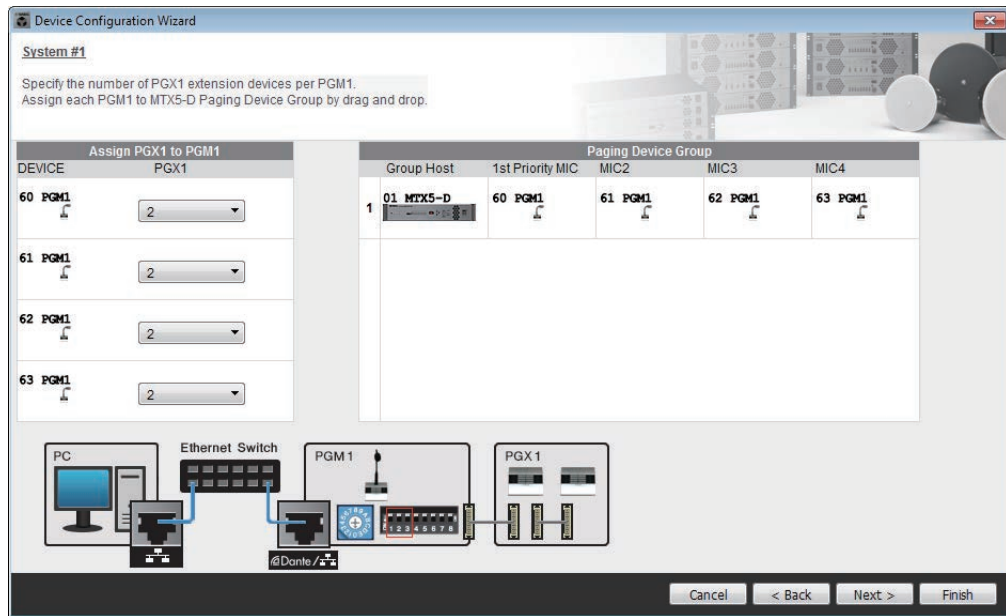

Here you can specify the number of PGM1 units which are extension units of the PGM1. You can also associate MTX5-D or MRX7-D units with PGM1 units, and specify the mic that is assigned as the 1st Priority Mic for the associated MTX5-D or MRX7-D.

- **[PGX1] list box**  
Selects the number of PGX1 units that are connected to the PGM1.
- **[Paging Device Group] area**  
Drag and drop to associate MTX5-D or MRX7-D units with PGM1 units. The PGM1 unit that is dropped on the [1st Priority Mic] row will be the 1st Priority Mic.  
As the 1st Priority Mic, assign the PGM1 unit that needs to interrupt even if another mic is broadcasting, such as for an emergency broadcast.
- **[Cancel] button**  
Cancels the operation and exits the wizard.
- **[< Back] button**  
Returns to the previous screen.
- **[Next >] button**  
Proceeds to the next screen.
- **[Finish] button**  
Applies the changes and closes the wizard. A confirmation message will ask whether you want to view a configuration diagram. If you click the [Yes] button, the configuration diagram (“Configuration Diagram” dialog box) will appear (→step 10). If you click the [No] button, the wizard will close without displaying the configuration diagram.

**8. Select the Mini-YGDAI card that is inserted in the slot. (Only if a device that has a slot is included in the MTX/MRX system.)**

In the case of the MRX, use MRX Designer to assign a SLOT component.

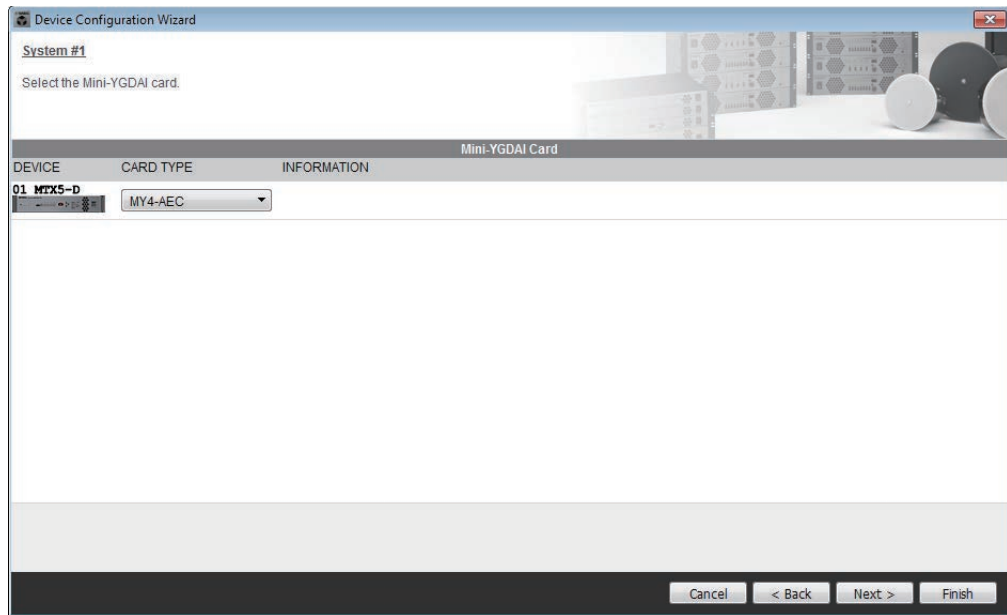

- **Card selection box**

Select the Mini-YGDAI card that is inserted in the slot.

**NOTE** *If the inserted Mini-YGDAI card is being operated in emulation mode, select the card that is being emulated.*

- **[Cancel] button**

Cancels the operation and exits the wizard.

- **[< Back] button**

Returns to the previous screen.

- **[Next >] button**

Applies the changes and proceeds to the next screen.

- **[Finish] button**

Applies the changes and closes the wizard. A confirmation message will ask whether you want to view a configuration diagram. If you click the [Yes] button, the configuration diagram (“Configuration Diagram” dialog box) will appear (→step 10). If you click the [No] button, the wizard will close without displaying the configuration diagram.

## 9. Make configuration settings for digital control panels (DCP).

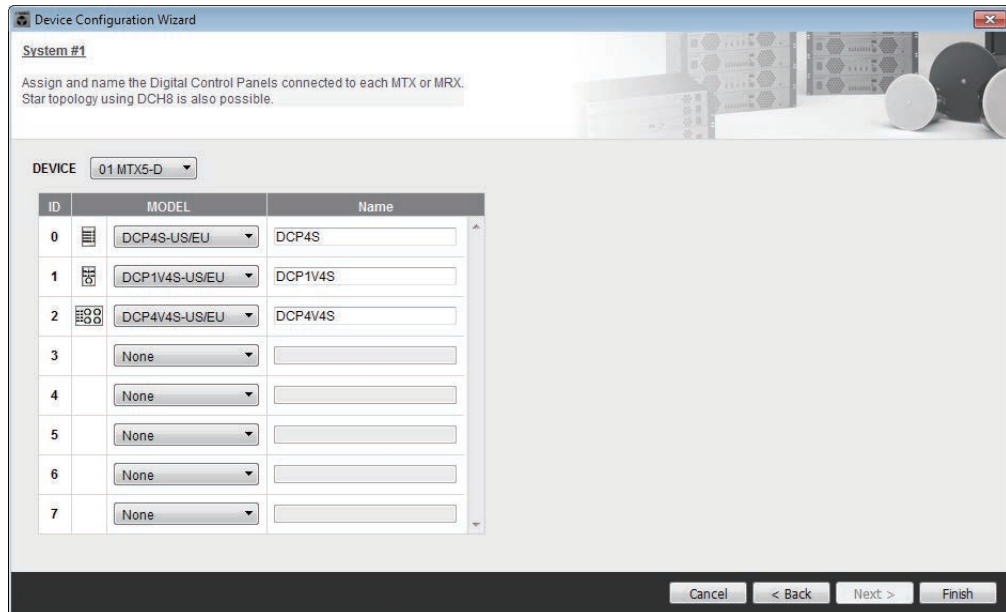

Select the DCP units that you want to connect to the MTX/MRX. You’ll make settings individually for each MTX/MRX unit. As desired, you can assign a name to each DCP unit.

DCP units can also be connected in a star topology by using the Yamaha DCH8 digital controller hub.

- **[Device] box**  
Select the MTX/MRX unit to which you want to connect DCP units.
- **[Model] box**  
Select the model of DCP. A graphic of the DCP is shown at the left.
- **[Name] box**  
Assign the desired name to each DCP.
- **[Cancel] button**  
Cancels the operation and exits the wizard.
- **[< Back] button**  
Returns to the previous screen.
- **[Next >] button**  
This button will be dimmed and unavailable.
- **[Finish] button**  
Applies the changes and closes the wizard. A confirmation message will ask whether you want to view a configuration diagram. If you click the [Yes] button, the configuration diagram (“Configuration Diagram” dialog box) will appear (→step 10). If you click the [No] button, the wizard will close without displaying the configuration diagram.

**10.** The “Configuration Diagram” dialog box will appear.

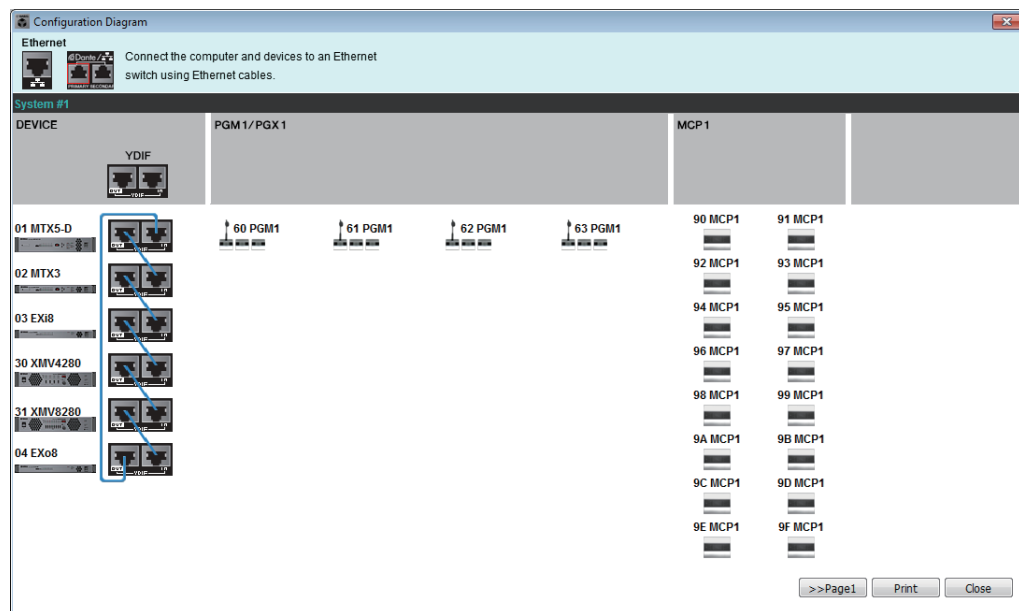
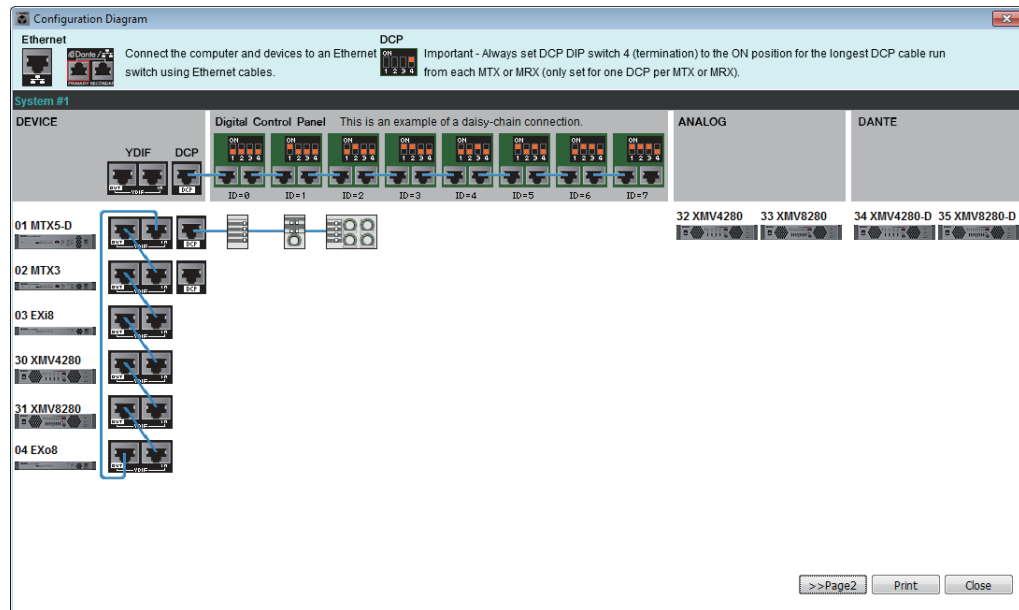

A configuration diagram of the system you constructed using the wizard is shown. Following the directions in the dialog box, connect each device and specify the panel ID of each DCP.

You can use the [Print] button to print this configuration diagram for convenient reference when you’re working at the actual location. This dialog box will also appear if you choose [Print Configuration Diagram] from the [File] menu.

- **[>>Page2]/[>>Page1] buttons**  
Switch the page to display.
- **[Print] button**  
Prints the configuration diagram.
- **[Close] button**  
Closes the dialog box.

## □ YDIF-connected devices

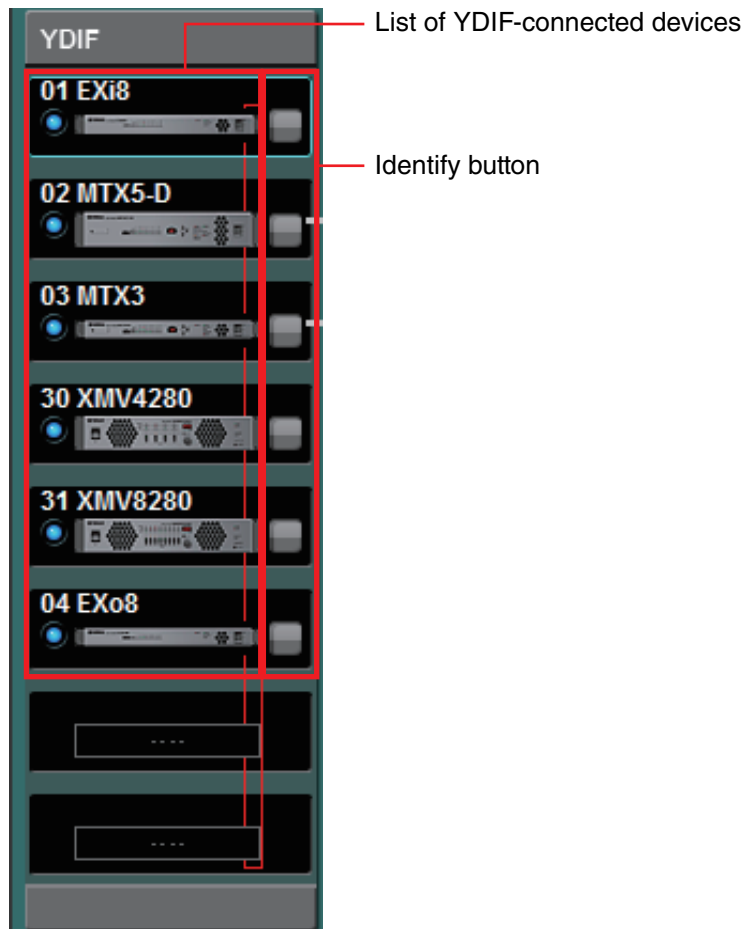





### List of YDIF-connected devices

These are the YDIF-connected devices within the MTX/MRX system. An online indicator, the UNIT ID, the device type, and a graphic of the device are shown.

If you double-click the graphic of a device, the description of the DIP switches (or the device setting DIP switches for the XMV) will be shown. If you double-click the device graphic when MTX-MRX Editor has recognized a device, the current DIP switch setting (or for the XMV, both device setting DIP switches and [SPEAKERS] DIP switches) will appear. If you double-click an XMV graphic while online, the current settings of the DIP switches are shown, allowing you to make HPF settings for each channel.

The online indicator and the device graphic show the online status and whether an alert has occurred. For more about alerts, refer to [\[Alert\] tab](#) and “[Alert list](#).”

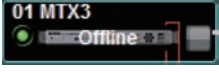
The currently-selected device is enclosed by a blue border.

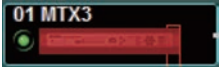
Indication	Online indicator	Device icon	Status
	Unlit	Dimmed	Does not exist on the network, or is not connected to the computer (MTX-MRX Editor).
	Lit blue	Indication	Exists on the network, and is synchronized with MTX-MRX Editor (online status).
	Lit green	“Offline” indicated on the icon	Exists on the network, but is not synchronized with MTX-MRX Editor (offline status).
	Lit blue	Red (*)	Synchronized with MTX-MRX Editor (online status), and an alert has occurred.
	Lit green	Red (*)	Not synchronized with MTX-MRX Editor (offline status), and an alert has occurred.

(\*) The red state will be cleared when you click the device icon or close the automatically-displayed popup.

## Identify button

When you click this, the indicator of the corresponding device will flash for approximately five seconds, allowing you to identify the device.

## □ Digital control panel, PGM1/PGX1

Digital Control Panel/PGM1 switching button

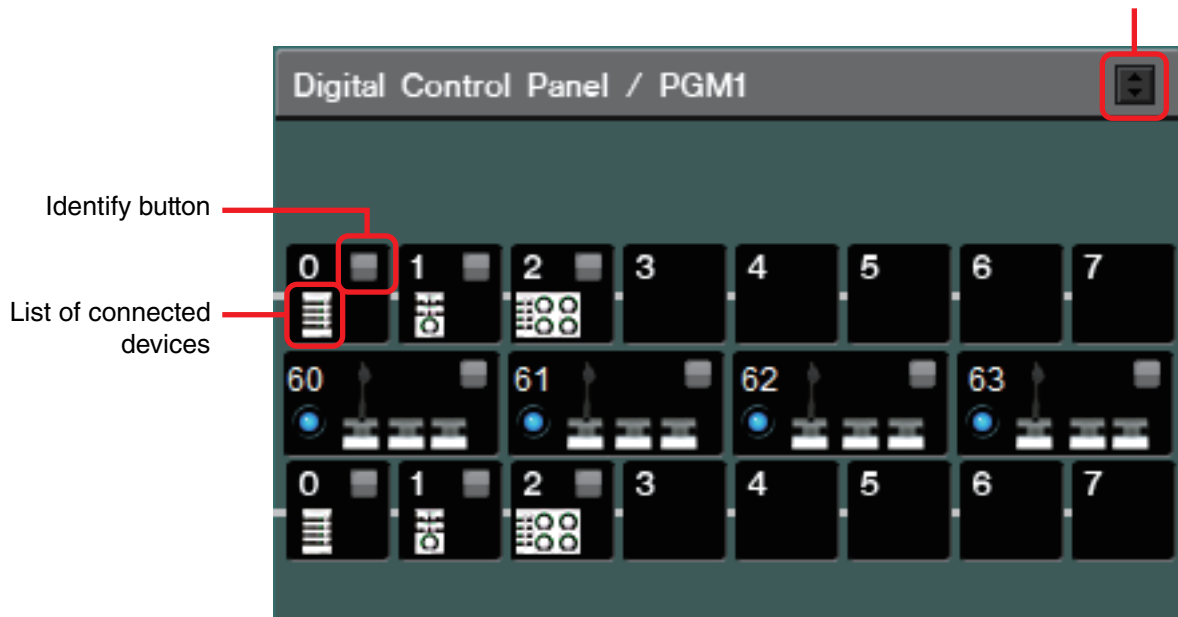

This area shows an illustration and panel ID for each of the digital control panel (DCP) units and PGM1/PGX1 units assigned by the wizard. Up to eight DCP units can be connected to one MTX/MRX unit.

Up to four PGM1 units can be connected to one MTX/MRX system. The PGM1 can control only a single MTX5-D/MRX7-D unit. The left-most PGM1 is the 1st Priority Mic. For more about the 1st Priority Mic, refer to [“ZONE” screen](#).

### Digital Control Panel/PGM1 switching button

Selects whether to show the Digital Control Panel or the PGM1.

This is available when the [System] tab/[Device] tab/[Alert] tab is expanded.

### List of connected devices

This shows the digital control panels and PGM1/PGX1 units that are connected to MTX/MRX units in the MTX/MRX system.

If you double-click the graphic of a PGM1, an explanation of the device setting DIP switches will be shown. If you double-click the graphic of a PGM1 when online, the current setting of the DIP switches will be shown.

### Identify button

When you click this, the indicator of the corresponding device will flash for approximately five seconds, allowing you to identify the device.

## □ Analog-connected devices

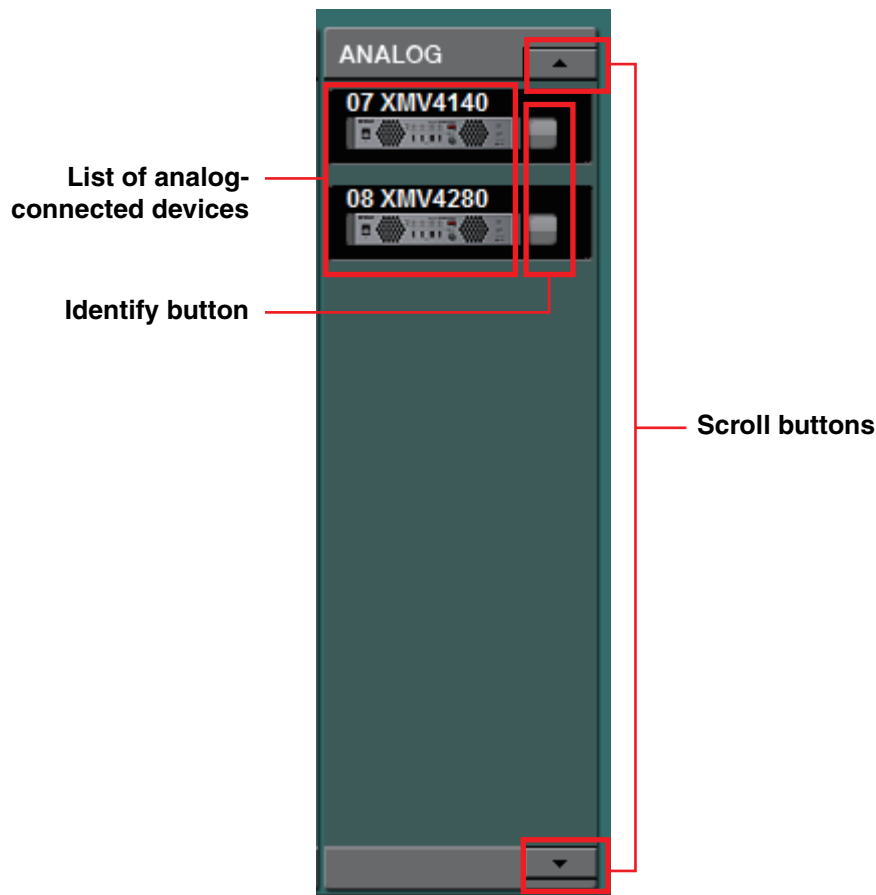

Of the devices controlled by MTX-MRX Editor, this area shows the devices whose audio signals are connected via analog.

### List of analog-connected devices

This shows the XMV units within the MTX/MRX system that are connected to the MTX/MRX via an analog connection.

If you double-click the device graphic, a description of the device setting DIP switches will appear. If you double-click the device graphic when MTX-MRX Editor has recognized a device, the current settings both of the device setting DIP switches and of the [SPEAKERS] DIP switches are shown. If you double-click the graphic of a device while online, the current settings of the DIP switches are shown, allowing you to make HPF settings for each channel.

### Identify button

When you click this, the indicator of the corresponding device will flash for approximately five seconds, allowing you to identify the device.

### Scroll buttons

Use these to scroll the display up or down.

## □ DANTE-connected devices

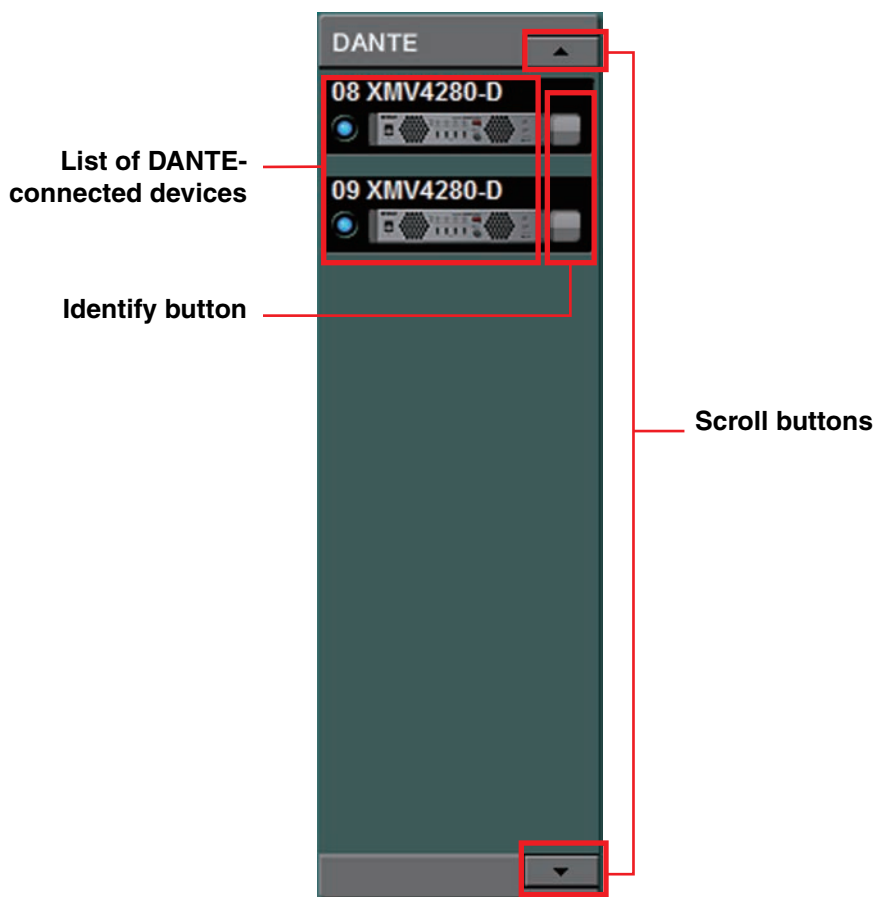

Of the devices controlled by MTX-MRX Editor, the Dante units other than the MTX/MRX or PGM1 are shown here.

### List of Dante-connected devices

These are the Dante units within the MTX/MRX system, except for the MTX/MRX and PGM1. An online indicator, the UNIT ID, the device type, and a graphic of the device are shown. If you double-click the graphic of a device, the description of the DIP switches (or the device setting DIP switches for the XMV) will be shown. If you double-click the device graphic when MTX-MRX Editor has recognized a device, the current DIP switch setting (or for the XMV, both device setting DIP switches and [SPEAKERS] DIP switches) will appear. If you double-click the graphic of a device while online, the current settings of the DIP switches are shown, allowing you to make HPF settings for each channel on the XMV. For more about the online indicators, refer to [“YDIF-connected devices.”](#)

### Identify button

When you click this, the indicator of the corresponding device will flash for approximately five seconds, allowing you to identify the device.

### Scroll buttons

Use these to scroll the display up or down.

## □ MCP1

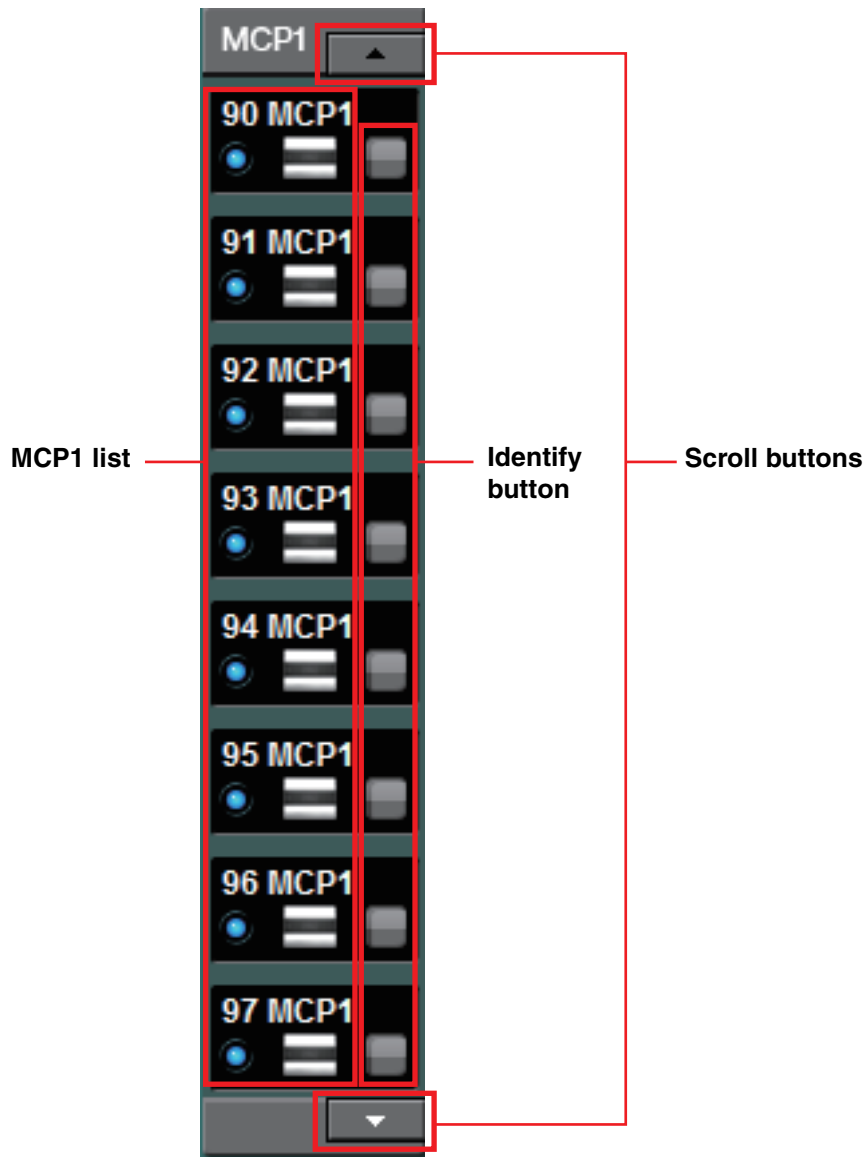

Of the devices controlled by MTX-MRX Editor, the MCP1 units are shown here.

### **MCP1 list**

These are the MCP1 units that are connected within the MTX/MRX system. An online indicator, the UNIT ID, the device type, and a graphic of the device are shown.

For details on the online indicator, refer to [YDIF-connected devices](#).

### **Identify button**

When you click this, the UNIT ID is shown on the display of the corresponding device, and its switches will flash for approximately five seconds, allowing you to identify the device.

### **Scroll buttons**

Use these to scroll the display up or down.

## [System] tab

This shows information about the MTX/MRX system.

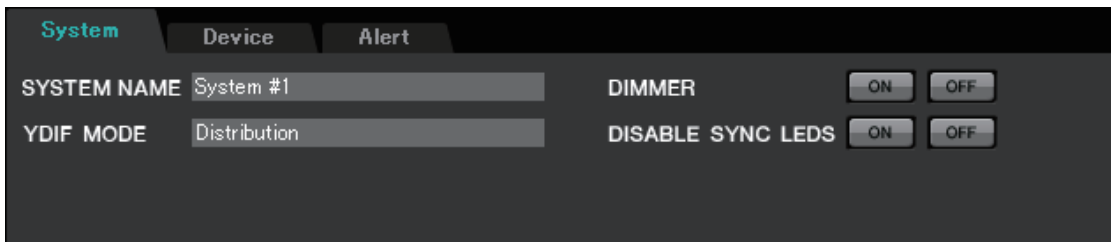

- **[SYSTEM NAME]**

This shows the system name that you entered in the [SYSTEM NAME] input box of the “[Device Configuration Wizard](#)” dialog box. If you want to change this, click the [Device Config] button and make changes in the “Device Configuration Wizard” dialog box.

- **[YDIF MODE]**

This shows the YDIF connection mode that you specified as the [YDIF MODE] in the “[Device Configuration Wizard](#)” dialog box. If you want to change this, click the [Device Config] button and make changes in the “Device Configuration Wizard” dialog box.

- **[DIMMER]**

If you click the [ON] button, the indicators of all devices in the MTX/MRX system will be dimmed simultaneously. When you click the [OFF] button, they will return to their original brightness.

This does not function on the R series (AD/DA) or the Tio1608-D.

- **[DISABLE SYNC LEDS]**

If you click the [ON] button, the [SYNC] indicators of the Dante devices in the MTX/MRX system will no longer light. When you click the [OFF] button, they will be able to light.

This does not function on the R series (AD/DA) or the Tio1608-D.

## [Device] tab

When you click a device other than a digital control panel, information for that device is shown.

### For the MTX3/MTX5-D/MRX7-D

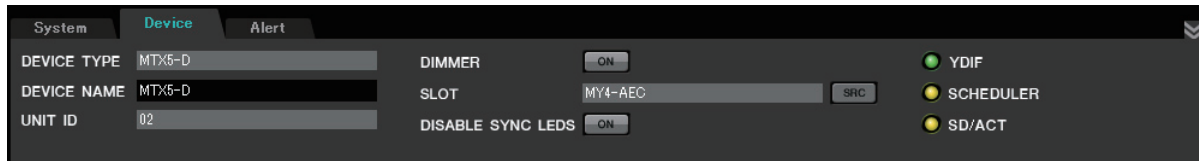

### For the EXi8/EXo8

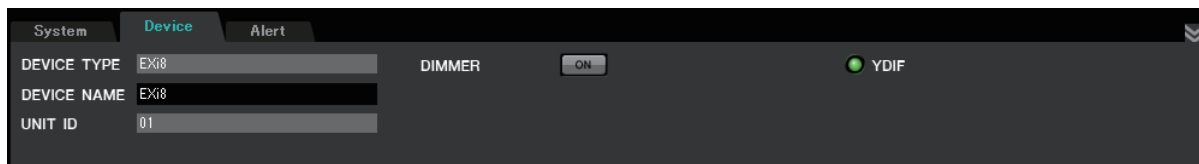

### For an XMV

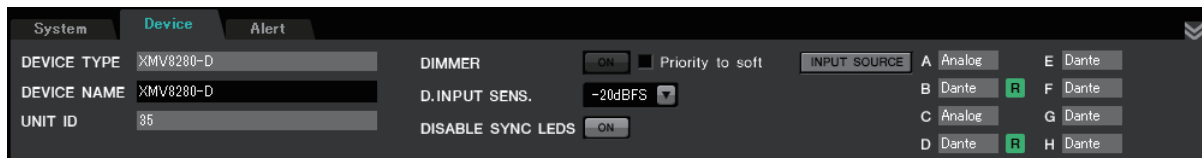

### For the PGM1/MCP1/R series (AD/DA)/Tio1608-D



- **[DEVICE TYPE]**

Indicates the type of device.

- **[DEVICE NAME]**

Indicates the device name. You are free to assign a desired name.

- **[UNIT ID]**

Indicates the UNIT ID.

- **[DIMMER]**

If you click the [ON] button to make it light, the indicators of the corresponding device will be dimmed. When you click the [ON] button once again, the indicators will return to their original brightness.

The XMV's [DIMMER] is enabled when you select the [Priority to soft] check box. In this case, the setting from MTX-MRX Editor will take priority over the settings of the DIP switches on the device itself.

This setting is transmitted and received when the device is synchronized with MTX-MRX Editor. It is synchronized with the device only when online.

- **[SLOT] (MTX5-D/MRX7-D only)**

Indicates the Mini-YGDAI card specified in the “Device Configuration Wizard” dialog box. The [SRC] button is shown if an MY4-AEC or MY8-AE96S is selected. Click this to open the “[Sampling Rate Converter](#)” dialog box.

- **[INPUT SOURCE] button (XMV only)**

For each channel, this indicates whether the input is analog or digital. When you click this, the “[Input Source/Redundant](#)” dialog box will appear. An “R” symbol is shown beside a digital input that is specified as Redundant. The “R” symbol turns yellow if the input has switched from digital to analog.

- **[D.INPUT SENS.] (XMV only)**

This specifies the input sensitivity from YDIF or Dante. If you select “-20 dBFS,” the input sensitivity will be the same as the analog connectors.

**NOTE** *If you change from [-3 dBFS] to [-20 dBFS], the output from the XMV will be louder for the same attenuator value. If you want to change this, lower the level and attenuator value before you make the change.*

- **[YDIF] indicator (YDIF-enabled models only)**

When online, this indicator is lit green if the rear panel [YDIF IN] jack is correctly connected to another device’s [YDIF OUT] jack.

- **[SCHEDULER] indicator (MTX/MRX only)**

When online, this indicator is lit yellow if an event has been set in the Scheduler, and will flash one minute prior to the event.

- **[SD/ACT] indicator (MTX/MRX only)**

When online, this indicator is lit yellow if an SD memory card is inserted into the SD memory card slot and is recognized correctly. The indicator will flash if the unit is accessing the SD memory card.

- **[DISABLE SYNC LEDS] (MTX/MRX/XMV Dante-enabled models only)**

If you click the [ON] button to make it light, the [SYNC] indicator of the device will no longer light. When you click the [ON] button once again to turn it off, the indicator will be able to light.

## [Alert] tab

Alert notifications from a device are shown by a popup window in MTX-MRX Editor (see “[Alert list](#)”). Even if you close this popup window, you can use this tab to view alerts that have occurred in the past. The R-series (AD/DA) and Tio1608-D are excluded.

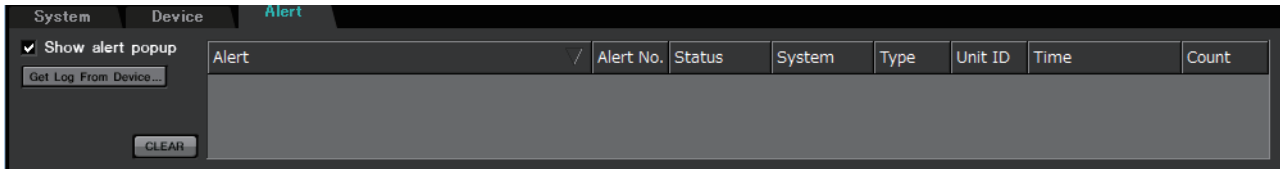

- **[Show alert popup] check box**

If this is selected, a popup window will appear when alert notifications are received from a device.

- **[Get Log From Devices] button**

The “[Get Log](#)” dialog box will appear.

- **[CLEAR] button**

Clears the currently-shown alert list.

- **Alert list**

- **[Alert]**  
Shows the contents of the alert and an icon.  
If you click the blue button, the “Solution” dialog box will appear, showing a solution if one exists.
- **[Alert No.]**  
Shows the alert number.
- **[Status]**  
Shows the status of the event. In the case of an alert, this will indicate “Occurred” when the alert occurs. There are two types of alert: momentary and continuing. In the case of a continuing alert, this will indicate “Resolved” when the condition has ended.
- **[System]**  
This indicates the name of the MTX/MRX system in which the device is installed.
- **[Type]**  
Indicates the type of device.
- **[Unit ID]**  
Indicates the UNIT ID of the device.
- **[Time]**  
Indicates the date and time that the alert occurred.
- **[Count]**  
Indicates the total number of times that the same event occurred.

- NOTE**
- The contents of the alert list will be deleted if you exit the project file that's being edited or if you reload a new file. If you want to view a past alert list, use “[Get Log](#)” dialog box to receive the log.
  - The alert list is saved within the device, but if the allowable memory size is exceeded, the alerts will be overwritten starting with the oldest.
  - When you use the [\[Get Log From Devices\]](#) button, alert lists produced by devices other than the MTX/MRX will also be obtained.

# Chapter 4. System screen

This screen shows the audio signal flow within the MTX/MRX system. From this screen you can move to other editing screens.

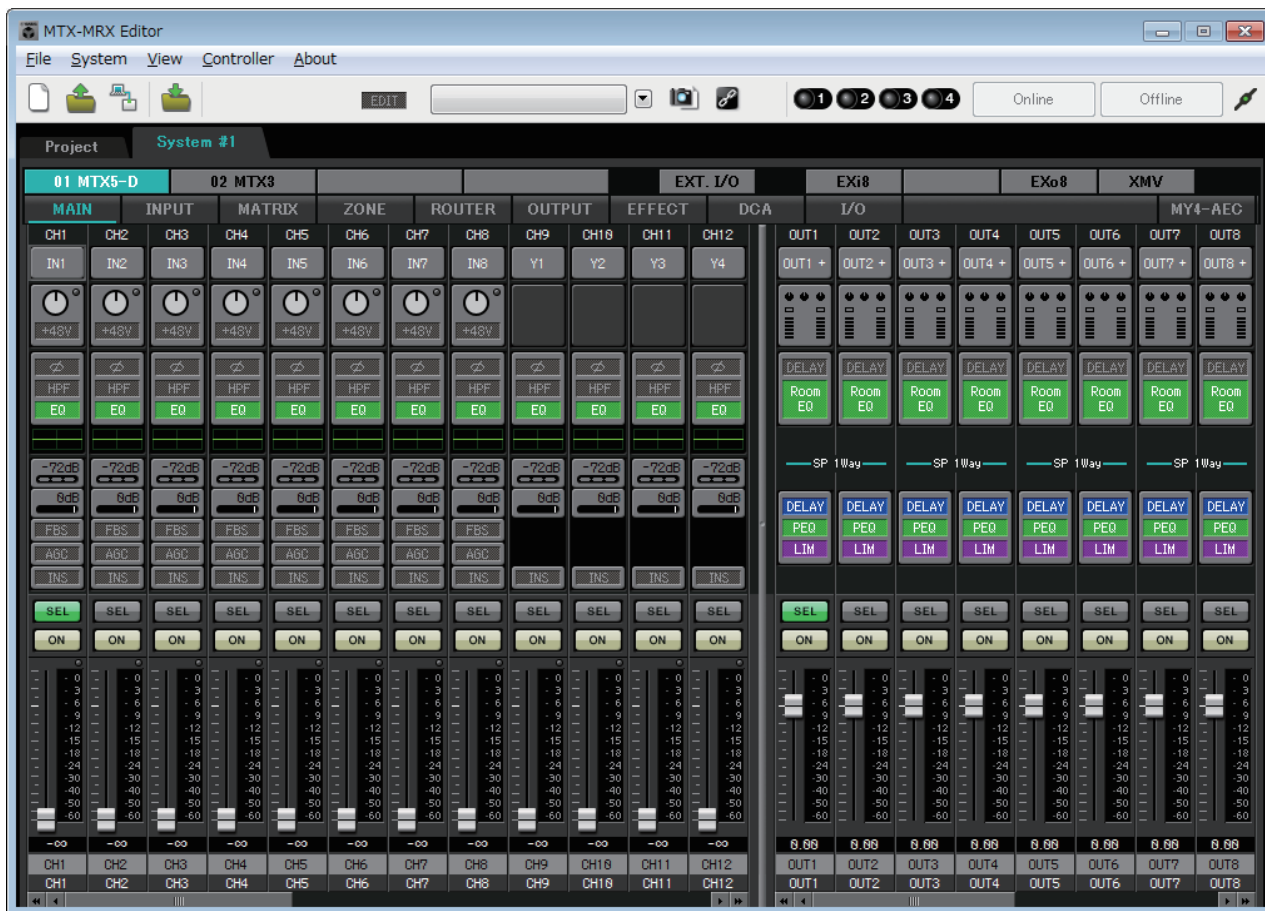

## Screen select buttons

Use these buttons to switch between units in the MTX/MRX system and to access various functions.

01 MTX5-D	02 MTX3					EXT. I/O	EXi8	R/Tio	EXo8	XMV	
MAIN	INPUT	MATRIX	ZONE	ROUTER	OUTPUT	EFFECT	DCA	I/O			MY4-AEC

### ● [MTX]/[MRX] buttons

Use these buttons to select the MTX/MRX unit whose settings you want to edit. The button shows the UNIT ID and device name. There will be one [MTX]/[MRX] button for each MTX/MRX unit in the MTX/MRX system.

In the “MRX” screen, click the [Open MRX Designer] button to access the “MRX Designer” window. For details, refer to “MRX Designer User Guide.”

- **[MAIN] button**  
Displays the “MAIN” screen.
  - **[INPUT] button**  
Displays the “INPUT” screens.
  - **[MATRIX] button**  
Displays the “MATRIX” screen.
  - **[ZONE] button**  
Displays the “ZONE” screen.
  - **[ROUTER] button**  
Displays the “ROUTER” screen.
  - **[OUTPUT] button**  
Displays the “OUTPUT” screens.
  - **[EFFECT] button**  
Displays the “EFFECT” screen.
  - **[DCA] button**  
Displays the “DCA” screen.
  - **[I/O] button**  
Displays the “I/O” screen.
  - **[MY4-AEC] button**  
Displays the “MY4-AEC” screen.
- **[EXT. I/O] button**  
Displays the “EXT. I/O” screen.
  - **[EXi8] button**  
Displays the “EXi8” screen.
  - **[R/Tio] button**  
Displays the “R/Tio” screen.
  - **[EXo8] button**  
Displays the “EXo8” screen.
  - **[XMV] button**  
Displays the “XMV” screen.

## Explanation of basic operation

### Changing the screen size



By dragging the right edge of the screen you can change the horizontal width of the screen. If you're using a large monitor, this is a convenient way to view numerous channel strips simultaneously.

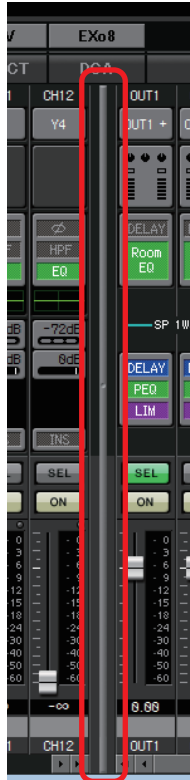

By dragging the scroll bar in the center of the screen to the left or right, you can change the proportion of input channel faders and output channel faders that are shown.

If stereo input channels and direct input channels are hidden, drag the scroll bar at the bottom of the screen to left or right to make these channels visible.



### ● Focus



The currently selected item is enclosed by a flashing border (this area is subsequently referred to as the “focus”). Use the <Tab> key to move the focus (<Shift>+<Tab> will move in the opposite direction). Left-clicking a button has the same effect as pressing the <Enter> key while focus is on that item.

### ● Faders/knobs



Drag upward to increase the value, or downward to decrease the value. If focus is on the fader or knob, you can also use the mouse wheel or the <↑><↓> keys.

By holding down the <Alt> key and clicking the knob or fader, you can set it to the nominal value. You can right-click a fader and select an input value.

### ● Numeric box



Drag upward to increase the value, or downward to decrease the value. If focus is on the fader or knob, you can also use the mouse wheel or the <↑><↓> keys.

You can double-click to enter edit mode and specify a numeric value. In edit mode, you can use <Ctrl>+<C> (hold down the <Ctrl> key and press the <C> key) to Copy, <Ctrl>+<V> to Paste, and press the <Enter> key to confirm the value.

# “MAIN” screen

This screen shows the input/output channels. From here you can access various editing screens.

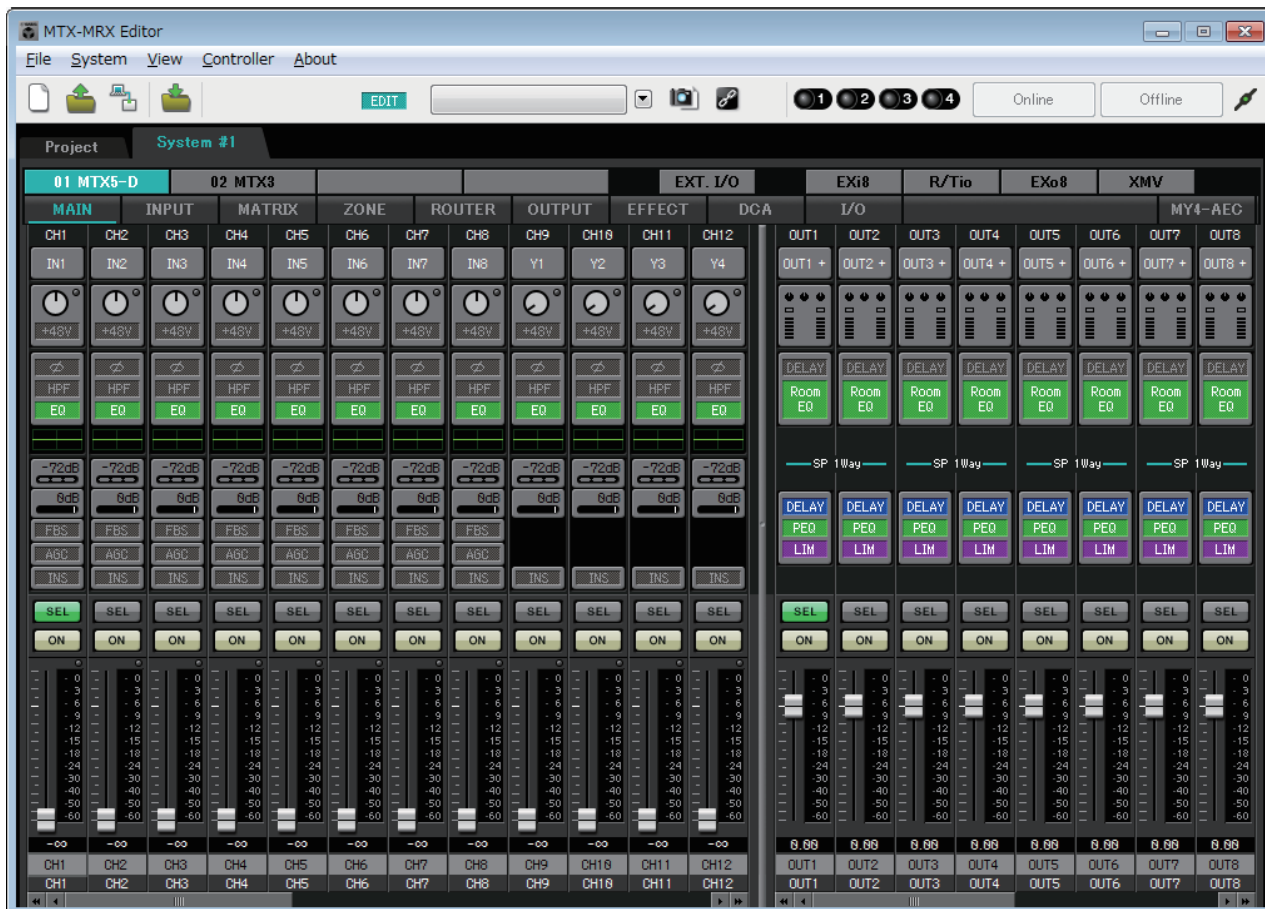

The types of channel and the number of channels are as follows.

	MTX5-D	MTX3
<b>Input channels</b>	CH1–CH16	CH1–CH8
<b>Stereo input channels</b>	STIN1L, STIN1R, STIN2L, STIN2R, STIN3L, STIN3R	
<b>Effect return channels</b>	Fx RTN1, Fx RTN2	
<b>Direct input channels</b>	CH17–CH24	CH9–CH16
<b>Output channels</b>	OUT1–OUT16	OUT1–OUT8

## Input channels

Input channel settings are made in the [INPUT CHANNEL SETUP] section of the “MTX Configuration” dialog box.

The description in this section assumes that two mono channels are used. If stereo channels are used, some settings will be shared between channels.

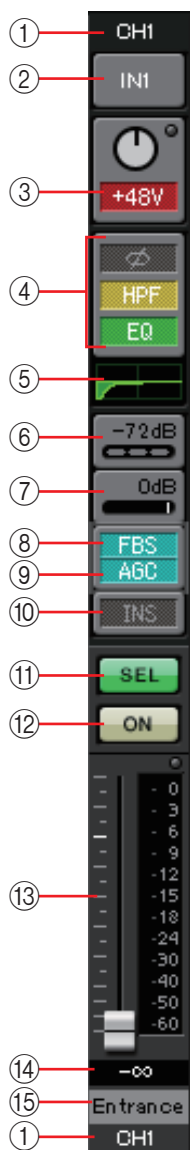

### ① Channel index

Shows the MTX's input channel number.

### ② Port select button

Opens the “Input Patch” dialog box. The button shows the currently selected port.

### ③ Port/external device parameter access button

This button displays a popup screen where you can edit the parameters of the MTX's input connector and the parameters of the external device that is associated those channels, eight channels at a time.

#### • Indicator

This will light green when the port signal input reaches a certain level (-40 dBFS), and will light red when it clips (-3 dBFS or higher).

#### • GAIN

Shows the output gain of the port.

#### • [48V]

Shows the +48V (phantom power) on/off status.

### Parameter edit screen (for the MTX)

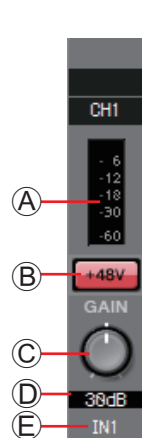

#### Ⓐ Meter

Shows the input signal level.

#### Ⓑ [+48V] button

Turns the HA phantom power (+48V) on/off.

### Notice

Be sure to leave this button off if you do not need phantom power.

Follow the important precautions below, in order to prevent noise and possible damage to external devices as well as the unit when you operate this switch.

- Be sure to leave this button off when you connect a device that does not support phantom power to [INPUT] connector.
- Do not connect/disconnect a cable to/from [INPUT] connector while this button is on.
- Down the output level to the minimum before operating this button.

**NOTE** There is no master switch. To avoid malfunctions, be sure to set this appropriately for the equipment that is connected.

#### Ⓒ [GAIN] knob

Adjusts the analog gain of the HA (head amp)

#### Ⓓ HA analog gain

Shows the HA analog gain setting.

#### Ⓔ Channel index

Indicates the name and number of the device's input connector.

## Parameter edit screen (for the EXi8)

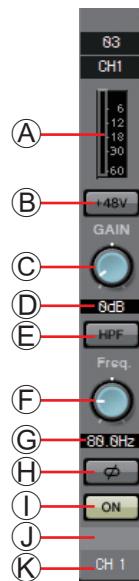

- Ⓐ **Meter**  
Shows the input signal level.
- Ⓑ **[+48V] button**  
Turns the HA phantom power (+48V) on/off.

### Notice

Be sure to leave this button off if you do not need phantom power. Follow the important precautions below, in order to prevent noise and possible damage to external devices as well as the unit when you operate this switch.

- Be sure to leave this button off when you connect a device that does not support phantom power to [INPUT] connector.
- Do not connect/disconnect a cable to/from [INPUT] connector while this button is on.
- Down the output level to the minimum before operating this button.

**NOTE** There is no master switch. To avoid malfunctions, be sure to set this appropriately for the equipment that is connected.

- Ⓒ **[GAIN] knob**  
Adjusts the analog gain of the HA (head amp)
- Ⓓ **HA analog gain**  
Shows the HA analog gain setting.
- Ⓔ **[HPF] button**  
Switches the HPF (High Pass Filter) on/off.
- Ⓕ **[Freq.] knob**  
Specifies the cutoff frequency of the HPF.
- Ⓖ **Cutoff frequency**  
Indicates the cutoff frequency of the HPF.
- Ⓗ **[Ø] button**  
Switches the phase of the input signal.
- Ⓘ **[ON] button**  
Switches the input channel on/off.
- Ⓙ **Channel name**  
Indicates the channel name of the EXi8. You can double-click this and edit it.
- Ⓚ **Channel index**  
Indicates the number of the device's input connector. If you place the cursor here, a popup will show the UNIT ID and the name of the external device.

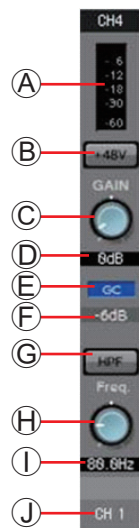
**Parameter edit screen (for the R series (AD/DA) except the Ro8-D)****A Meter**

Shows the input signal level.

**B [+48V] button**

Turns the HA phantom power (+48V) on/off.

**Notice**

**Be sure to leave this button off if you do not need phantom power. When turning phantom power on, you must observe the precautions below in order to prevent noise and possible damage to the unit and to external devices.**

- Leave this button off if a device that does not support phantom power is connected to the [INPUT] connector.
- Do not connect/disconnect a cable to/from the [INPUT] connector while this button is on.
- Lower the output level to the minimum before turning phantom power on/off.

**C [GAIN] knob**

Adjusts the analog gain of the HA (head amp).

**D HA analog gain**

Shows the HA analog gain setting.

**E [GC] indicator**

Indicates the gain compensation on/off status.

**F Compensation gain value**

Indicates the gain value fixed by the gain compensation. This is not shown if gain compensation is off.

**G [HPF] button**

Switches the HPF (High Pass Filter) on/off.

**H [Freq.] knob**

Specifies the cutoff frequency of the HPF.

**I Cutoff frequency**

Indicates the cutoff frequency of the HPF.

**J Channel index**

Indicates the number of the device's input jack. If you place the cursor here, a popup will show the UNIT ID and the name of the external device.

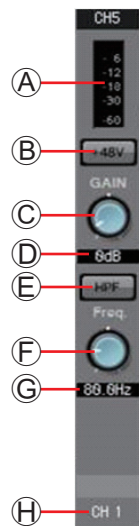
**Parameter edit screen (for the Tio1608-D)****A Meter**

Shows the input signal level.

**B [+48V] button**

Turns the HA phantom power (+48V) on/off.

**Notice**

**Be sure to leave this button off if you do not need phantom power. When turning phantom power on, you must observe the precautions below in order to prevent noise and possible damage to the unit and to external devices.**

- Leave this button off if a device that does not support phantom power is connected to the [INPUT] connector.
- Do not connect/disconnect a cable to/from the [INPUT] connector while this button is on.
- Lower the output level to the minimum before turning phantom power on/off.

**C [GAIN] knob**

Adjusts the analog gain of the HA (head amp).

**D HA analog gain**

Shows the HA analog gain setting.

**E [HPF] button**

Switches the HPF (High Pass Filter) on/off.

**F [Freq.] knob**

Specifies the cutoff frequency of the HPF.

**G Cutoff frequency**

Indicates the cutoff frequency of the HPF.

**H Channel index**

Indicates the number of the device's input jack. If you place the cursor here, a popup will show the UNIT ID and the name of the external device.

- ④ **“GAIN/HPF/EQ” screen access button**  
Switches to the “GAIN/HPF/EQ” screen. The button also shows the on/off status.
- ⑤ **EQ/HPF indication**  
This shows a miniature (non-editable) version of the graph that is shown in the “GAIN/HPF/EQ” screen. This is not shown if HPF and EQ are off.
- ⑥ **“GATE” screen access button**
- ⑦ **“COMP” screen access button**  
Switches to the “GATE/COMP” screen. The button also shows the current value and on/off status.
- ⑧ **“FBS” screen access button**
- ⑨ **“AGC” screen access button**  
Switches to the “FBS/AGC” screen. The button also shows the on/off status. In the case of the MTX3, this will be only CH1 through CH4.
- ⑩ **[INS] button (MTX5-D only)**  
This button displays a popup screen where you can edit the insert on/off setting eight channels at a time. If this is on, the audio signal will be sent from POST ON to the Mini-YGDAI card installed in [SLOT].  
**NOTE** *If no Mini-YGDAI card is installed, or if the installed Mini-YGDAI card does not support insertion, there will be no audio output if this is turned on.*
- ⑪ **[SEL] button**  
Selects the channel that you want to edit.
- ⑫ **[ON] button**  
Switches the input channel on/off. The button also shows the on/off status.
- ⑬ **Fader/meter**  
Adjusts the input level. You can right-click the fader to access the popup menu, and select [0 dB] or [-Infinity].  
If you right-click the input channel meter, a popup menu will appear, allowing you to choose [EQ OUT] or [POST ON]. If you choose [EQ OUT], the indicator above the meter will light.
- ⑭ **Input channel volume**  
Edits/indicates the level of the input channel.
- ⑮ **Channel name**  
Indicates the channel name. You can double-click this and edit it.

**HINT** *Some of the channel parameters can be copied and pasted.*

### ● Component copy

Drag (left-click and move) the component that you want to copy, and drop it (release the right-click) on the desired channel.

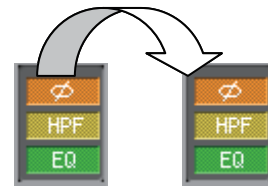

Alternatively, you can right-click a component to access a menu. Select [Copy] and then select [Paste] for the desired channel.

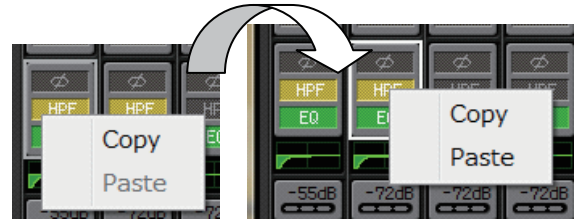

**NOTE** The following components can be copied: GAIN/HPF/EQ, GATE/COMP, AGC, GAIN/EQ, COMP/AGC, DELAY/ROOM EQ, and SPEAKER PROCESSOR. However of [GAIN/HPF/EQ], [Ø] is not copied.

### ● Channel copy

Right-click the [SEL] button to access the menu. Select [Channel Copy] and then select [Channel Paste] for the desired channel. All parameters of the channel will be pasted.

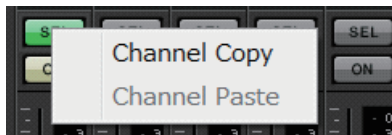

## Stereo input channels

Stereo input channel settings are made in the [INPUT PORT SETUP] section of the “[MTX Configuration](#)” dialog box.

Input channel settings are made in the [INPUT CHANNEL SETUP] section of the “[MTX Configuration](#)” dialog box.

The description in this section assumes that STEREO channels are used.

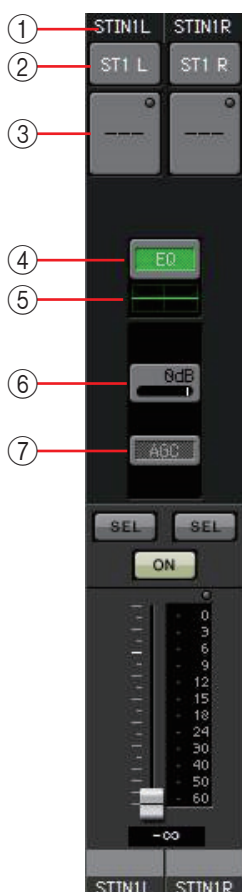

### ① Channel index

Shows the MTX's input channel number.

### ② Port select button

Opens the “[Input Patch](#)” dialog box. The button shows the currently selected port.

### ③ Port/external device parameter access button

For details, refer to [Input channels](#).

### ④ “GAIN/EQ” screen access button

Switches to the “[GAIN/EQ](#)” screen. The button also shows the on/off status. This is not shown if HPF and EQ are off.

### ⑤ EQ indication

This shows a miniature (non-editable) version of the graph that is shown in the “[GAIN/EQ](#)” screen. This is not shown if HPF and EQ are off.

### ⑥ “COMP” screen access button

Switches to the “[COMP/AGC](#)” screen. The button also shows the current value and on/off status. STIN3 does not provide the capability of specifying COMP or AGC.

### ⑦ “AGC” screen access button

Switches to the “[COMP/AGC](#)” screen. The button also shows the on/off status. In the case of the MTX3, this will be only STIN1 and STIN2.

For details on adjusting the following parameters, refer to [Input channels](#).

- [SEL] button
- [ON] button
- Fader/meter
- Input channel volume
- Channel name

## Effect return channels

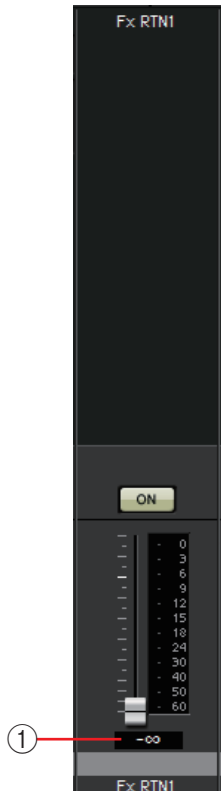

### ① Effect return volume

This parameter specifies the amount of audio signal processed by the effect that will be returned.

For details on adjusting the following parameters, refer to [Input channels](#).

- Channel index
- [ON] button
- Fader/meter
- Channel name

## Direct input channels

Direct input channel settings are made in the [INPUT CHANNEL SETUP] section on the [INPUT] tab of the “[MTX Configuration](#)” dialog box.



For details on adjusting the following parameters, refer to [Input channels](#).

- Channel index
- Port select button
- Port/external device parameter access button
- [ON] button
- Fader/meter
- Input channel volume
- Channel name

## Output channels

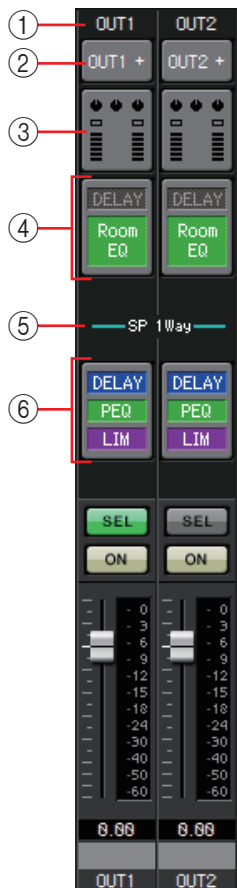

### ① Channel index

Indicates the number of the MTX's output channel.

### ② Port select button

Opens the “[Output Patch](#)” dialog box. The button shows the currently selected port. If more than one port is assigned, a [+] is shown at the end of the port name.

### ③ Port/external device parameter access button

This button displays a [Parameter editing screen](#) where you can edit the parameters of the MTX's output connector and the parameters of the external device that is associated with that channel.

### ④ “DELAY/ROOM EQ” screen access button

Switches to the “DELAY/ROOM EQ” screen. The button also shows the on/off status.

### ⑤ SP 1way/SP 2way indication

Indicates the signal type of the output channel. Output channel settings are made in [OUTPUT CHANNEL SETUP] of the “[MTX Configuration](#)” dialog box.

### ⑥ “SPEAKER PROCESSOR” screen access button

Switches to the “SPEAKER PROCESSOR” screen. The button also shows the on/off status.

For details on adjusting the following parameters, refer to [Input channels](#).

- [SEL] button
- [ON] button
- Fader/meter
- Output channel volume
- Channel name

## Parameter editing screen

An output can be assigned to more than one device.

In the explanatory screens shown here, the assignments are as follows.

<b>Upper line</b>	Left	MTX [OUTPUT] connector parameters
	Center	MTX [DANTE] parameters
	Right	MTX [SLOT] parameters
<b>Lower line</b>	Left	EXo8 parameters
	Right	XMV parameters

The popup shows the MTX [OUTPUT] connector parameters if OUTPUT is selected in the “Output Patch” popup.

Parameters other than the MTX’s [OUTPUT] connector parameters will appear in the popup if a device has been assigned to the output route in the “EXT I/O” screen and the corresponding output is selected in the “Output Patch” popup.

**NOTE** If digital connections and analog connections coexist, we recommend that you set the XMV’s input sensitivity to  $[-20\text{ dBFS}]$  in the [Device] tab of the Project screen. If this is set to  $[-20\text{ dBFS}]$ , the digital connections and analog connections will have the same input sensitivity.

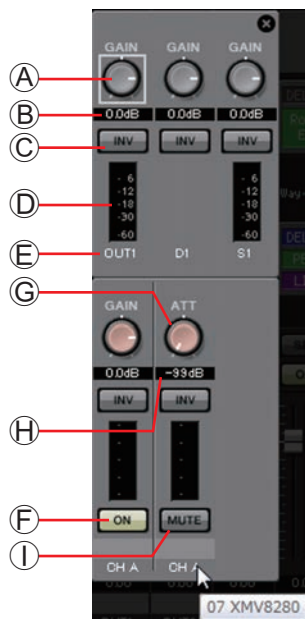

- Ⓐ **[GAIN] knob (for other than the XMV)**  
Adjusts the output gain.
- Ⓑ **Output gain (for other than the XMV)**  
Shows the output gain setting.
- Ⓒ **POLARITY button**  
Switches the polarity of the output signal.
- Ⓓ **Meter (for other than Dante)**  
Shows the output signal level.
- Ⓔ **Channel index**  
Indicates the connector number.  
In the case of an external device, you can place the cursor here to see a popup that shows the UNIT ID and the name of the external device.
- Ⓕ **[ON] button (EXo8 only)**  
Switches the output channel on/off.
- Ⓖ **[ATT] knob (XMV only)**  
Adjusts the XMV’s output attenuator.
- Ⓗ **Output attenuator (XMV only)**  
Shows the XMV’s output attenuator setting.
- Ⓘ **[MUTE] button (XMV only)**  
Switches mute on/off for the output channel.

## □ “Input Patch” dialog box

Here you can specify the connector or channel whose signal will be assigned to each input channel.

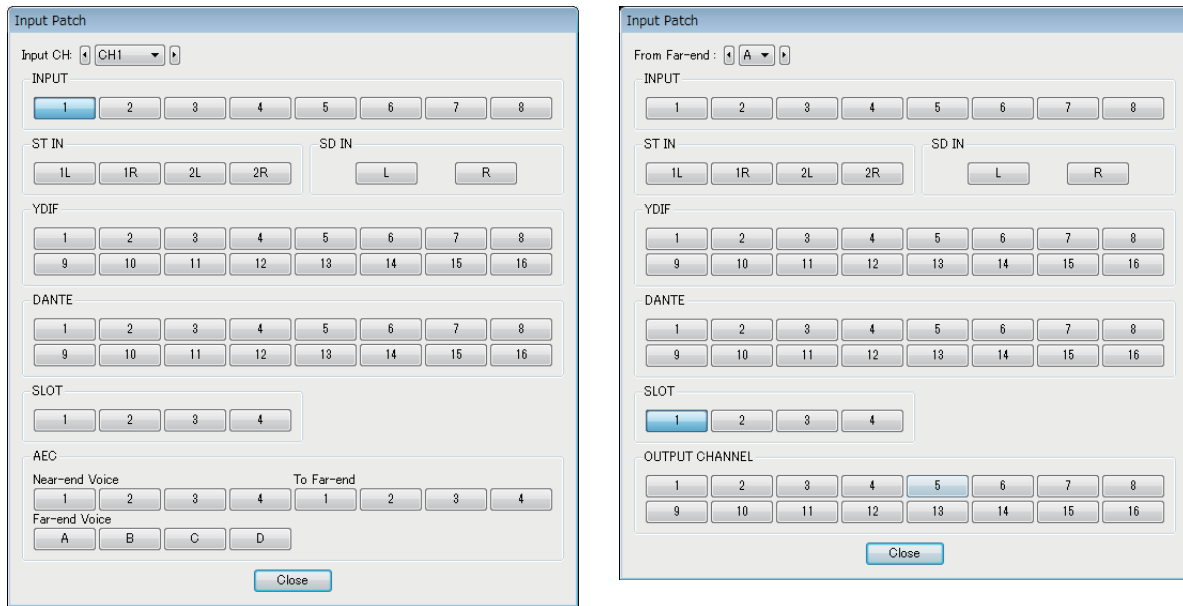

- **[Input CH] box**  
Selects the input source channel.
- **INPUT**  
These are the MTX’s [INPUT] connectors.
- **ST IN**  
These are the MTX’s [ST IN] connectors.
- **SD IN**  
This is the MTX’s SD memory card.
- **YDIF**  
This is the MTX’s [YDIF] connector.
- **DANTE (MTX5-D only)**  
This is the MTX5-D’s [Dante] connector.
- **SLOT (MTX5-D only)**  
This is the MTX5-D’s [SLOT].
- **AEC (MTX5-D only)**  
These are the signals processed by the MY4-AEC installed in the MTX5-D’s [SLOT]. These are not shown if the MY4-AEC is not installed. For details, refer to “MY4-AEC Owner’s Manual.”
- **OUTPUT CHANNEL (only for the MY4-AEC’s Near-end Mic. and From Far-end)**  
These are the MTX5-D’s output channels.
- **[Close] button**  
Closes the “Input Patch” dialog box.

## □ “Output Patch” dialog box

Here you can choose how the output channels will be assigned to connectors or channels. You can select multiple output connectors (except for Far-end Voice, and To Far-end).

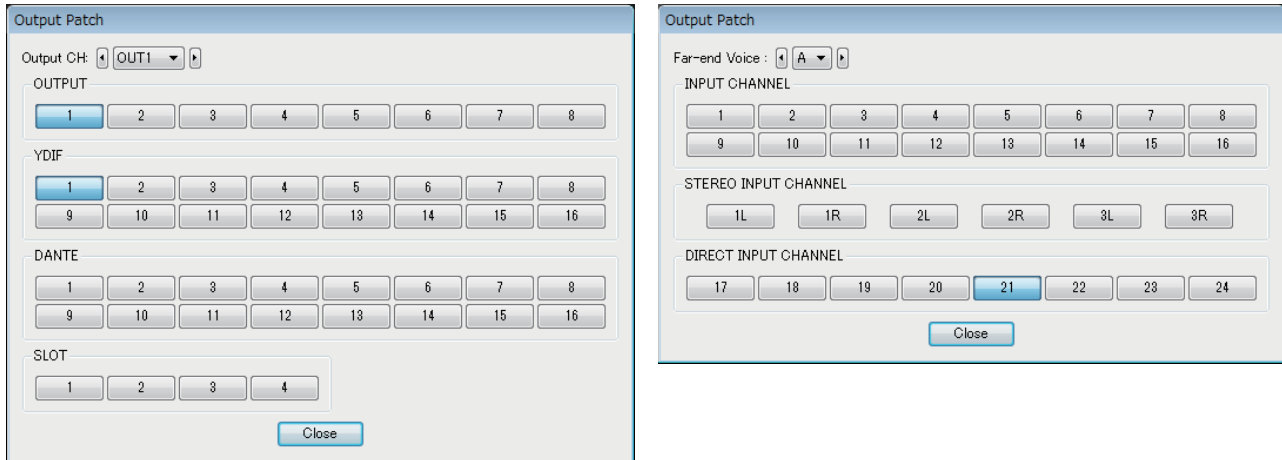

- **[Output CH] box**  
Selects the output channel.
- **OUTPUT**  
These are the MTX’s [OUTPUT] connectors.
- **YDIF**  
These are the channels that the MTX will output as YDIF. They are available only in Distribution mode.
- **DANTE (MTX5-D only)**  
This is the MTX5-D’s [Dante] connector.
- **SLOT (MTX5-D only)**  
This is the MTX5-D’s [SLOT].
- **INPUT CHANNEL (MY4-AEC’s Far-end Voice and To Far-end only)**  
These are the input channels of the MTX5-D.
- **STEREO INPUT CHANNEL (MY4-AEC’s Far-end Voice and To Far-end only)**  
These are the stereo input channels of the MTX5-D.
- **DIRECT INPUT CHANNEL (MY4-AEC’s Far-end Voice and To Far-end only)**  
These are the input channels of the MTX5-D.
- **[Close] button**  
Closes the “Output Patch” dialog box.

# “INPUT” screens

In these screens you can apply signal processing to the input channels.

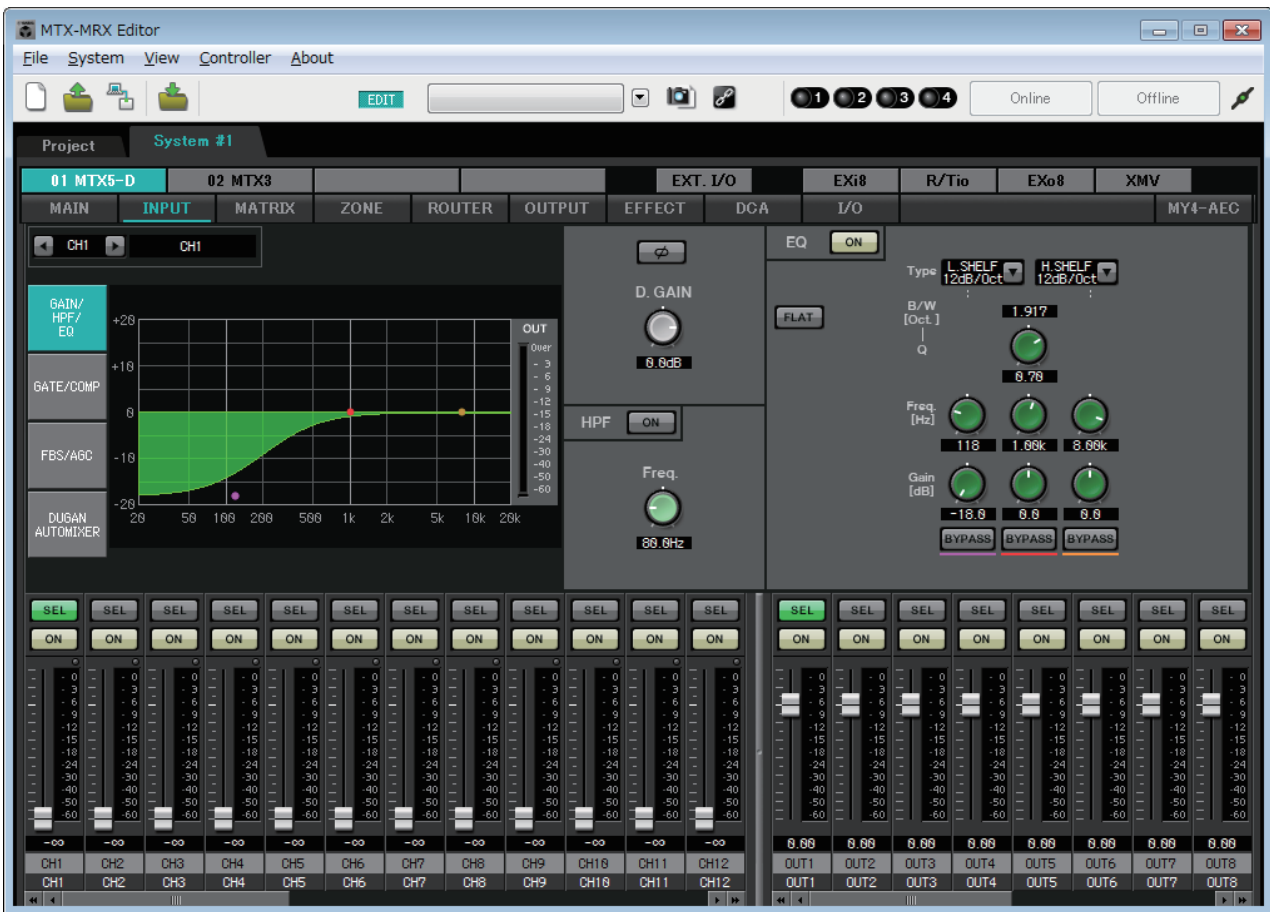

In this screen you can apply signal processing to the input channels. You can apply GAIN/HPF/EQ, GATE/COMP, FBS/AGC, and Dugan Automixer.

### ● Channel selection

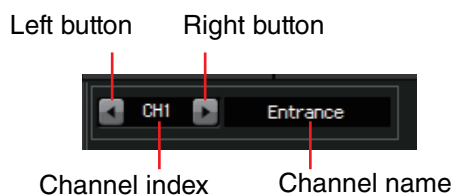

Use the left or right button to select the channel to which you want to apply signal processing.

### ● Screen selection

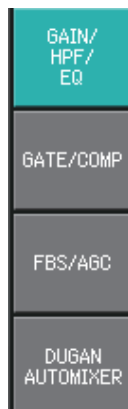

Click the appropriate button to select the screen that includes the channel processing you want to apply.

● **Operations common to the "INPUT" screens**

For details on the knobs and numeric boxes, refer to [Explanation of basic operation](#).

**HINT** You can copy channel settings to other channels. When you right-click within the area, a list box will appear. Select a channel, and paste the settings (the Phase setting of an input channel will not be copied).



## Input channels

### Signal flow

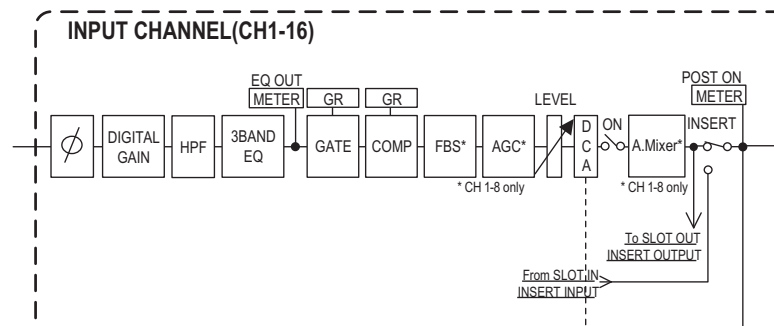

## "GAIN/HPF/EQ" screen

In this screen you can edit the GAIN, HPF, and EQ parameters.

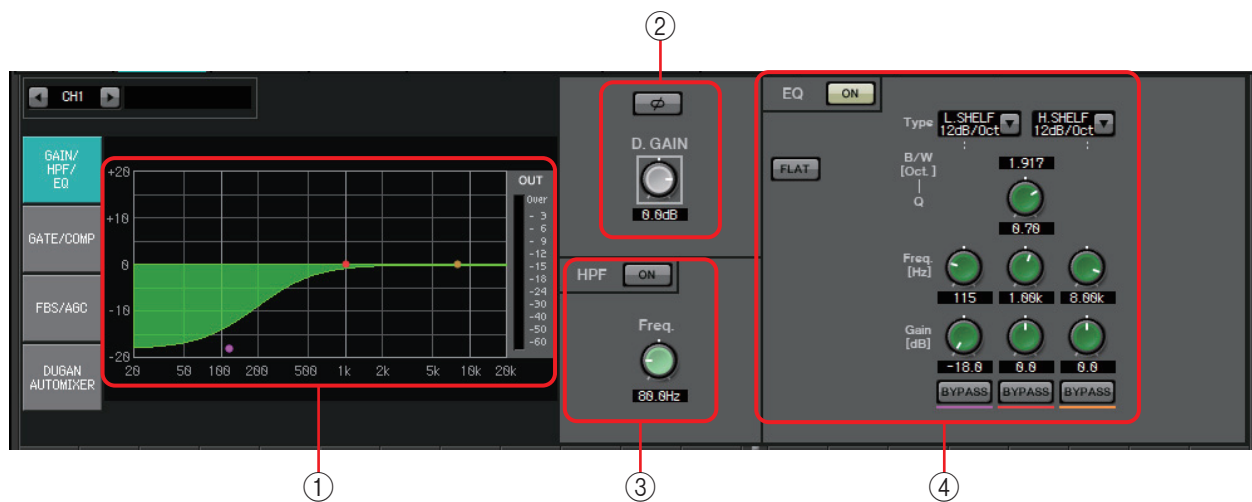

### ① EQ graph and OUT meter

The effect of the equalizer is shown as a graph. You can drag a control point to edit the parameters.

An OUT meter is shown at the right of the graph.

### ② GAIN setting area

- [Ø] button  
Switches the phase of the input signal.
- [D.GAIN] knob  
Adjusts the digital gain of the input signal.

### ③ HPF setting area

- HPF [ON] button  
Switches the HPF (High Pass Filter) on/off.
- [Freq.] knob  
Specifies the cutoff frequency of the HPF.

#### ④ EQ setting area

- **EQ [ON] button**  
Switches the EQ on/off.
- **[FLAT] button**  
Resets the EG gain (0 dB). A confirmation message will appear. Click the [Yes] button to execute.
- **[Type] list box**  
Select the type of EQ.  
The frequency response is shown by the EQ graph.

#### **PEQ (Parametric Equalizer)**

The volume in the region of the specified frequency will be boosted or cut according to the specified Q.

#### **L.SHELF (Low Shelf)**

The volume of the entire low-frequency region below the specified frequency will be boosted or cut. Use this for purposes such as bass boost. [6dB/Oct] and [12dB/Oct] specify the amount of attenuation per octave.

#### **H.SHELF (High Shelf)**

The volume of the entire high-frequency region above the specified frequency will be boosted or cut. Use this for purposes such as high boost. [6dB/Oct] and [12dB/Oct] specify the amount of attenuation per octave.

#### **HPF (High Pass Filter)**

The region below the specified frequency will be cut.

#### **LPF (Low Pass Filter)**

The region above the specified frequency will be cut.

- **[B/W] box/[Q] knob**  
Specifies the width of each frequency region. The [B/W] box specifies the setting in Octave units.
- **[Freq.] knob**  
Specifies the frequency of each frequency region.

**NOTE** *The variable range depends on the band. The Low (left) region has a lower limit of 20 Hz, and the Mid (center) and High (right) regions have a lower limit of 100 Hz.*

- **[Gain] knob**  
Specifies the amount of boost or cut that will be applied to the frequency.
- **[BYPASS] button**  
Temporarily turns off the EQ.

## “GATE/COMP” screen

In this screen you can adjust the GATE and COMP (Compressor) parameters.

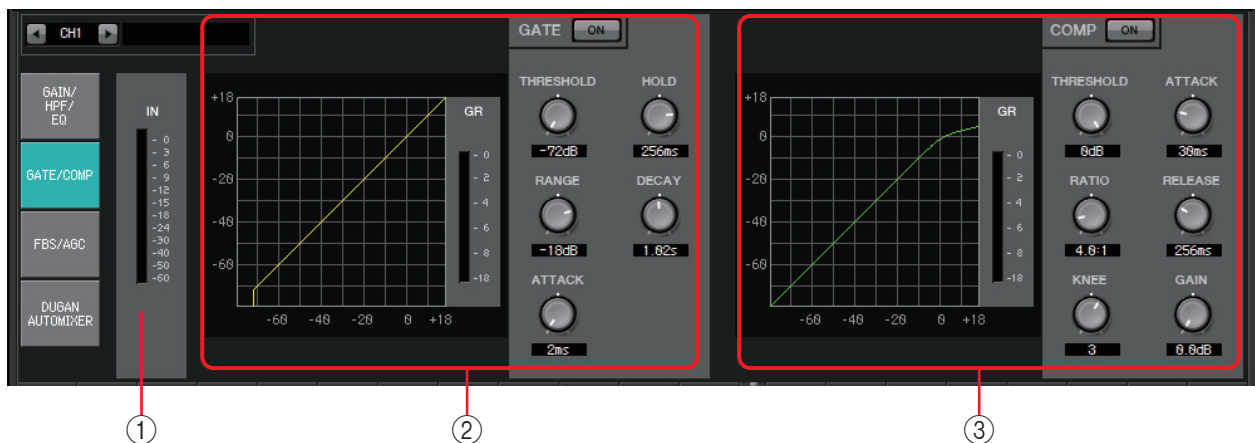

### ① IN meter

This is the input meter for the gate.

### ② GATE setting area

This type of signal processing passes the audio signal only while it exceeds a specified volume. Use this to cut low-level noise, such as when there is no input from a mic, or when the input is below a specified level (the threshold value).

- **GATE graph**

The effect of the gate is shown by this graph. The horizontal axis is the input level, and the vertical axis is the output level.

- **GR meter**

Indicates the amount of gain reduction.

- **GATE [ON] button**

Turns the gate on/off.

- **[THRESHOLD] knob**

Specifies the threshold level at which the gate will take effect.

- **[RANGE] knob**

Specifies the amount of attenuation applied when the gate is active.

- **[ATTACK] knob**

Specifies the attack time (the time from when the input signal exceeds the threshold until the gate opens).

- **[HOLD] knob**

Specifies the hold time (the time from when the input signal falls below the threshold until the gate begins to close).

- **[DECAY] knob**

Specifies the decay time (the time over which the gate closes after the hold time has elapsed).

### ③ **COMP setting area**

This type of signal processing compresses the dynamic range. Use this to prevent problems that can occur in the sound if the input exceeds a certain level (threshold).

- **COMP graph**  
The effect of the compressor is shown by this graph. The horizontal axis is the input signal level, and the vertical axis is the output level.
- **GR meter**  
Indicates the amount of gain reduction.
- **COMP [ON] button**  
Turns the compressor on/off.
- **[THRESHOLD] knob**  
Specifies the threshold level at which the compressor will take effect.
- **[RATIO] knob**  
Specifies the compression ratio.  
When the threshold level is exceeded, the output signal will be adjusted at the ratio specified by "input signal : output signal."  
For example with a setting of 4:1, the portion of the signal that exceeds the threshold value will be compressed to 1/4th.
- **[KNEE] knob**  
Specifies how compression will be applied.  
With the [HARD] setting, compression will operate like a limiter. If the [HARD] setting produces an unnatural impression, raise the value. However, raising the value excessively will increase the amount of compression for the portion below the threshold level.
- **[ATTACK] knob**  
Specifies the attack time (the time from when the input signal exceeds the threshold until the maximum compression is reached).
- **[RELEASE] knob**  
Specifies the release time (the time from when the input signal falls below the threshold until compression is no longer applied).
- **[GAIN] knob**  
Adjusts the output gain.

## “FBS/AGC” screen

In this screen you can edit the “FBS (Feed Back Suppressor)” and “AGC (Auto Gain Controller)” parameters.

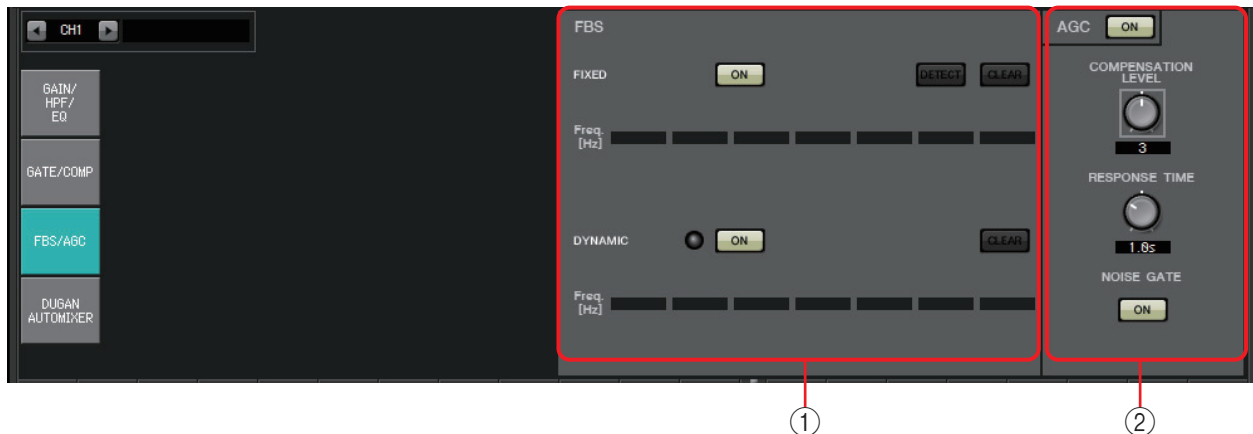

### ① FBS setting area

FBS (Feed Back Suppressor) is a function that prevents the unpleasant acoustic feedback that occurs when sound from a speaker is picked up by a mic and re-amplified. In addition to being unpleasant, acoustic feedback places a strain on the speakers, and can damage them. To prevent such feedback, place the speakers so that their sound will not be picked up by the mic and amplified. If acoustic feedback still occurs, you can use FBS to improve the feedback margin.

#### FIXED

After the speakers and mics have been installed, and while the MTX series settings are being made, this method proactively finds feedback points in the current sound system, and applies the appropriate filters. This is effective for mics whose position is fixed.

- **[ON] button**  
Applies the detection result.
- **[DETECT] button**  
Displays the [Detection start screen](#). This is available only when online.
- **[CLEAR] button**  
Clears the filter settings. A confirmation message will appear. Click the [Yes] button to execute.
- **[Freq.]**  
Displays the frequencies of the filters that were applied. Up to seven filters will be applied.

#### DYNAMIC

This method continually finds the changing feedback points while the MTX series unit is in use, and updates the filter settings accordingly. This is effective for wireless mics whose location is not fixed, and which can be used in a variety of positions.

- **[ON] button**  
Turns the DYNAMIC function on/off. FBS operation will begin when you turn this on.
- **[CLEAR] button**  
Clears the filter settings. A confirmation message will appear. Click the [Yes] button to execute.
- **[Freq.]**  
Displays the frequencies of the filters that were applied. Up to seven filters will be applied.

### Performing FBS detection for the FIXED type

In order to obtain good results, you should set up the mics, speakers, and other sound equipment, and adjust the output EQ settings before performing detection. If you want, FIXED can also be used in conjunction with DYNAMIC.

**1. Adjust the power amp output volume.**

While vocalizing into the mic, gradually raise the power amp output to the volume at which the system will be operated in actual use. In addition, clap your hands and verify that feedback does not occur.

**2. Maintain silence in the space for which you want to suppress feedback.**

**3. Select the input channels in MTX-MRX Editor.**

**4. Click the [FBS/AGC] button.**

**5. Click the FIXED [DETECT] button to open the detection start screen.**

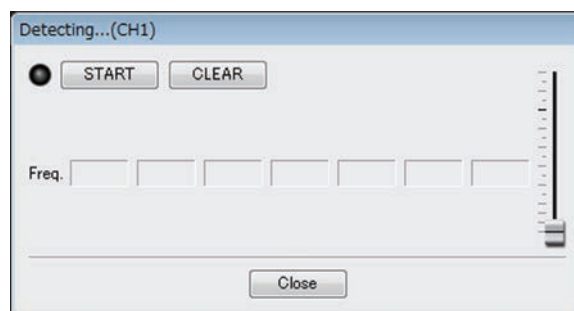

**6. Click the [START] button in the detection start screen. Detection will start.**

Raise the faders little by little during detection. You can make fine adjustments by operating the mouse wheel.

Feedback will occur, but the MTX will immediately detect that frequency and insert a filter. Repeat this operation. When you have obtained a satisfactory result, click the [STOP] button to end the procedure.

**7. After detection has ended, click the [CLOSE] button to close the screen.**

- NOTE**
- The indicator will light when the following occurs.
    - When a frequency is displayed
    - When a currently-displayed frequency is rewritten
  - If you don't notice any result, it may be that detection has failed. Click the [CLEAR] button to discard the detection result. If you want to make the settings once again, adjust the position of the mics and speakers, adjust the volume, and try the above procedure once again from step 1.
    - In some cases, detection will not occur correctly if the overall volume is raised excessively, or if the mics and speakers are too close, or if sound from a speaker is directly entering a mic.*
  - When using FIXED, calculation will continue repeatedly even after all seven filters have been displayed, for example to combine the frequencies that are closest to each other. However when using DYNAMIC, if all seven filters are already displayed but new feedback is found, the filter that was specified first and that will have the least effect on the audio quality will be discarded, and replaced by the newly-specified filter. A filter will be discarded automatically after a certain length of time has elapsed since it was applied.
  - It is not possible to completely eliminate all feedback in all environments.
  - If feedback increases when you raise a fader, and is not automatically suppressed, lower the fader to prevent the speakers from being damaged.

**HINT** The MTX cannot detect multiple feedback points simultaneously. Settings will be easier if you raise the fader slowly so that feedback occurs gradually.

## ② AGC setting area

AGC (Auto Gain Controller) is a function that automatically compensates the gain according to the input level, keeping a constant output level for an incoming signal whose level is changing. For example, differences in how closely and how loudly a person is speaking into a mic can make their amplified voice vary in volume, making it less intelligible. In such cases, the volume will be automatically adjusted within a fixed range.

Compensation Level	Threshold	Ratio
1	-21	1
2	-27.75	1.3
3	-34.5	2
4	-41.25	4
5	-48	20

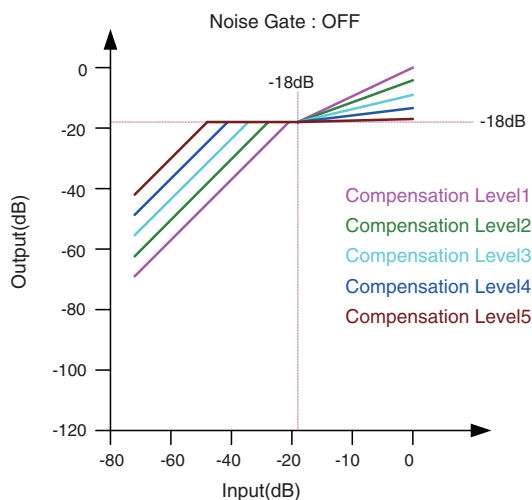

If the input is below the Threshold value, the output is adjusted so that the output is  $-18$  dB when it reaches the Threshold value.  
 If the input is above the Threshold value and below  $-18$  dB, the output is set to  $-18$  dB.  
 If the input is above the Threshold value and above  $-18$  dB, the output level is adjusted by the Ratio value.

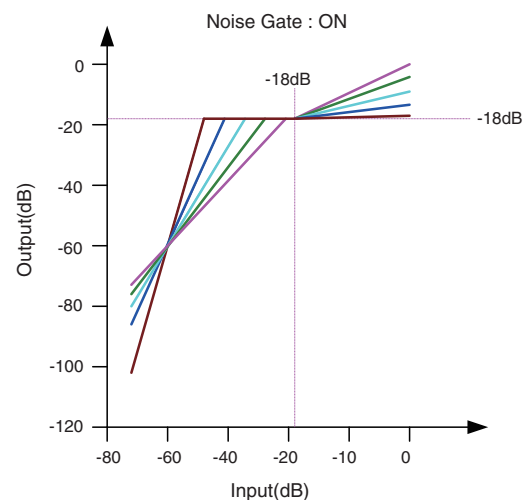

If the noise gate is on, the volume is adjusted so that input and output are the same level at  $-60$  dB, and then adjusted so that the output is  $-18$  dB when it reaches the Threshold value.  
 If the input is above the Threshold value and below  $-18$  dB, the output is set to  $-18$  dB.  
 If the input is above the Threshold value and above  $-18$  dB, the output level is adjusted by the Ratio value.

- **AGC [ON] button**  
Turns AGC on/off.
- **[COMPENSATION LEVEL] knob**  
Specifies the amount of gain compensation. Higher settings will produce more compensation.
- **[RESPONSE TIME] knob**  
Specifies the response speed for gain compensation. This applies to compensation that raises the gain; it is the time required for a 6 dB increase.
- **[NOISE GATE] button**  
Turns the noise gate on/off.

## “DUGAN AUTOMIXER” screen

In a system used for unscripted speech, the automixer detects the mics that are in use and automatically optimizes the gain distribution, maintaining a consistent system gain between multiple mics without requiring an engineer to be constantly adjusting the faders. The Dugan Automixer provided by the MTX automatically adjusts the automix gain of input channels 1–4 on the MTX3 or input channels 1–8 on the MTX5-D.

In this explanation, we describe using the Dugan Automixer with three mics.

When one person is speaking	When two people are speaking
<p>When one person speaks, the gain of that mic instantly rises, and the gain of the other mics decreases. The same thing happens when a different person speaks.</p>	<p>When two people speak simultaneously, the gain is automatically distributed between the two mics so that the total gain remains constant, and the gain of the remaining mic decreases.</p>

The Dugan Automixer differs from the functionality of a limiter or an auto level controller. When multiple people are speaking, the engineer can use the faders to adjust individual levels as usual. Even when nobody is speaking, the mic audio level is detected and the gain is distributed automatically, so the faders can be left raised.

The automixing algorithm is only complete when all the channels in an automixing group are summed.



### Master field

#### ① [reset] button

Resets the various parameters to their default values.

② **[meters] button**

Switches the meter display of the channel control field between gain/input/output.

**NOTE** When using [weight] to adjust the relative sensitivity between the input channels, switching the meter display to “gain” lets you use the channel control field to adjust the gain amount, providing better visibility.

③ **[OVERRIDE] button**

This function instantly mutes all mics except for a specific mic, such as the mic of the chair or head.

If this is on, channels whose [override] button is on are set to “man,” and channels whose [override] button is off are set to “mute.”

For the specified mic, such as of the chair or head, click the [override] button in the channel strip to make it light yellow. Press the button once again to return to the previous setting.

④ **[MUTE] button**

Turns mute on/off for all mics in the group.

**Channel control field**

This is color-coded by group.

Channels of the same group are mixed.

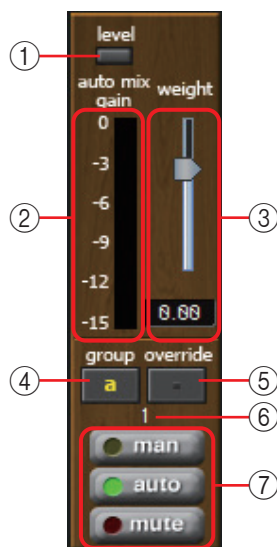

① **[level] indicator**

This lights green when the audio reaches the appropriate level for automixing.

**NOTE**

- If the [level] indicator goes dark, raise the mic input gain.
- If the [level] indicator lights red, lower the mic input gain.

② **Meter**

The meter provides three display modes: gain (green: automix gain) /input (yellow: input level) /output (blue: output level). The display mode switches each time you press the [meters] button in the master field.

**NOTE** Normally you will leave this in the “gain” display mode.

### ③ [weight] slider

Adjusts the relative sensitivity between input channels. Set the meter display to "gain," and adjust the weight setting so that the meters are at approximately the same level when there is no input. For example if noise is heard near a certain mic (e.g., air conditioner wind noise), lowering the weight value of that channel will reduce the noise.

The automixer calculates the proportion of a specific channel's input level relative to the mix of all inputs in the group. The following examples describe how weight control works.

#### ○ If the weight setting value is raised on one channel

- The automix gain value of that channel increases, and the value of other channels decreases.
- Channels with a high weight setting will more easily obtain automix gain in comparison to other channels.

#### ○ If the weight setting value is lowered on one channel

- The automix gain value of that channel decreases, and the value of other channels increases.
- If people speak simultaneously into multiple mics, it will be more difficult to differentiate them from the other mics.

### ④ [group] button

Selects the group to which each channel belongs. Click the button to switch the group. Two groups can be specified on the MTX3, or four groups on the MTX5-D.

### ⑤ [override] button

When the master field's [OVERRIDE] button is on, the setting of this button determines whether the corresponding channel switches to "man" mode or "mute" mode.

- If you turn on the [OVERRIDE] button of the master field when the [override] button of the channel control field is on, the channel mode changes to "man."
- If you turn on the [OVERRIDE] button of the master field when the [override] button of the channel control field is off, the channel mode changes to "mute."
- When the [OVERRIDE] button of the master field is turned off, that channel returns to its previous mode.

### ⑥ Input channel number

Indicates the input channel number.

### ⑦ [man]/[auto]/[mute] buttons

These buttons toggle the channel between man/auto/mute.

- man** : The audio is passed through without modifying the gain. Select this mode if singing into the mic.
- auto** : The automixer is turned on. Select this mode for conversation.
- mute** : The channel is muted.

## Stereo input channels

### Signal flow

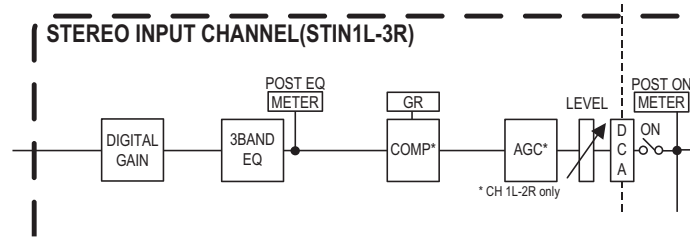

### “GAIN/EQ” screen

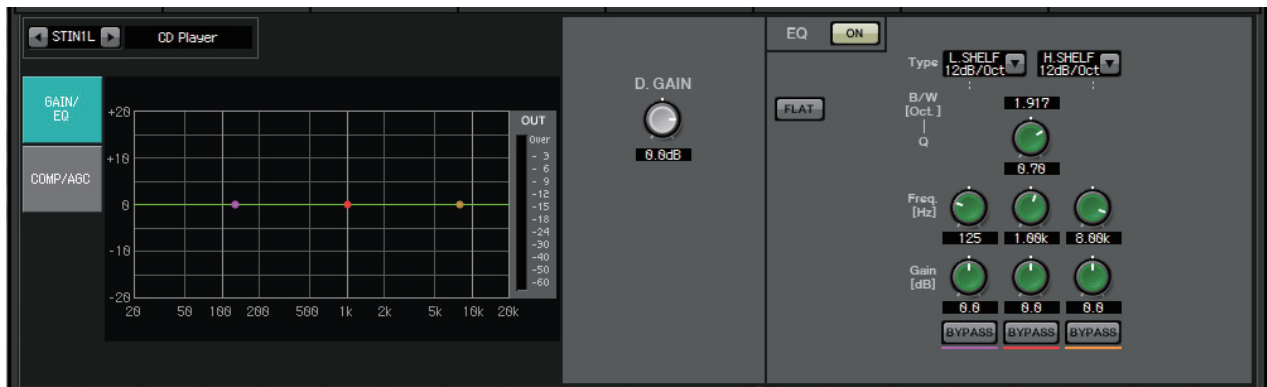

In this screen you can adjust the GAIN and EQ parameters. For details on these parameters, refer to [“GAIN/HPF/EQ” screen](#).

### “COMP/AGC” screen



In this screen you can adjust the COMP and AGC parameters. For details on these parameters, refer to [“GATE/COMP” screen](#) and [“FBS/AGC” screen](#).

**HINT** If you are playing a CD and the recorded level differs between songs to an unpleasant extent, it is effective to use the AGC function to adjust the levels.

# “MATRIX” screen

This screen mixes and sends the input channel signals.

In SENDS ON FADER mode, you can use the input channel faders to adjust the amount of the input channels that is sent to the matrix bus.

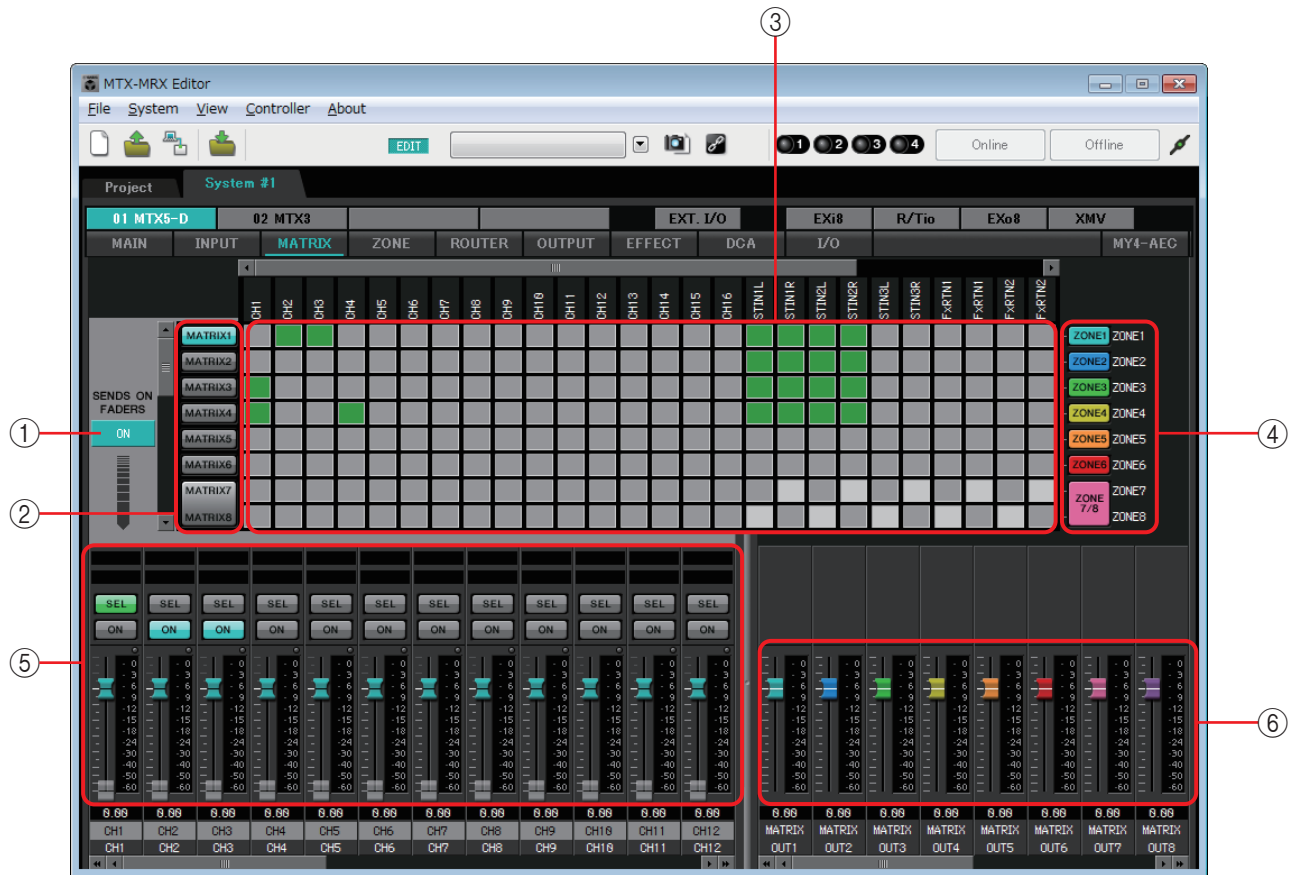

## Signal flow

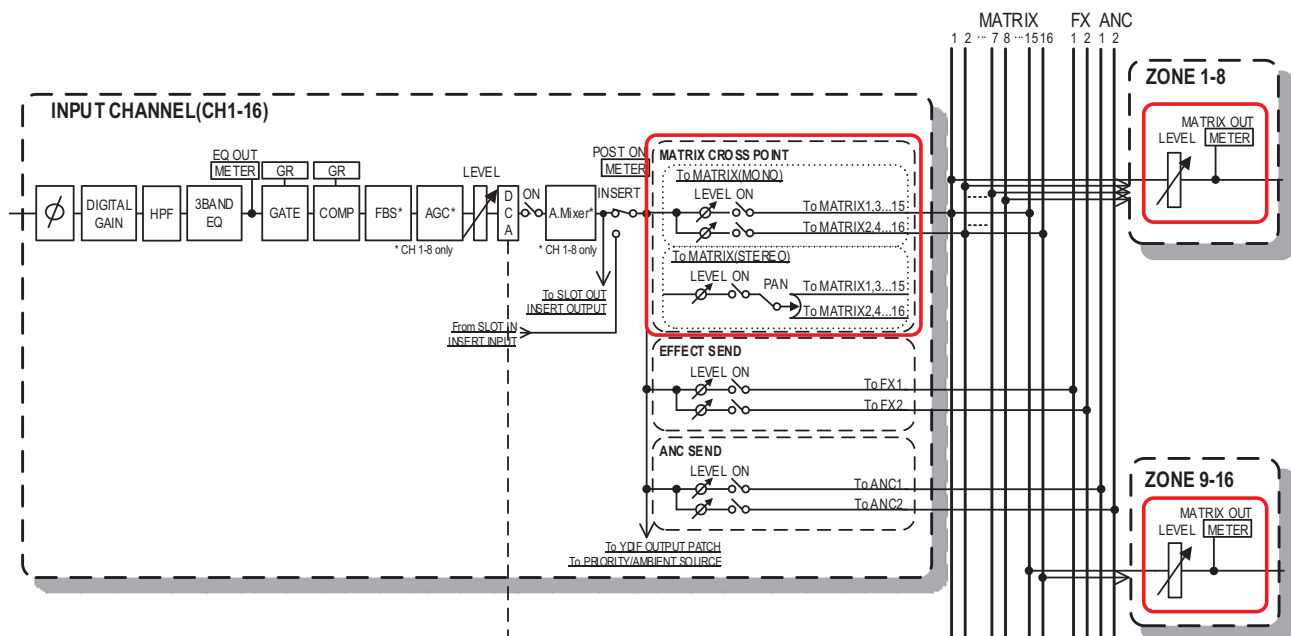

### ① SENDS ON FADERS [ON] button

Turns SENDS ON FADER mode on/off. If this is off, the input channel faders will adjust the input levels.

② **Matrix bus select buttons**

Select the matrix bus to which the signal will be sent. A pair of channels that are assigned as stereo is shown by a single button.

If you right-click the button, you’ll be able to set all send levels to the matrix bus in a single operation by choosing 0 dB, -3 dB, -6 dB, or -Infinity.

③ **Input channel matrix**

Shows the send level of each channel. The horizontal axis indicates the input channels, and the vertical axis indicates the send-destination matrix buses. The PAN or Blend settings are included in the send levels. Click here to turn send on/off. If you drag with the mouse, the send on/off settings over which the cursor passes will change to the state of the location from which you began dragging.



If a name has been assigned to the input channel or zone, the name is shown at the top or right of the matrix.

You can right-click a cross point and make multiple send on/off settings in a single operation by choosing Matrix ON (all horizontal axis on), Matrix OFF (all horizontal axis off), All ON (all on), or All OFF (all off).

- NOTE**
- Do not turn on the input channel matrix for an input channel that is connected to a PGM1 unit.
  - You can use the vertical and horizontal scroll bars to select ANC buses or other channels that are hidden.

④ **[ZONE] button**

Indicate the zones that are the matrix output destinations. Click a button to access the “ZONE” screen. A pair of channels that are assigned as stereo is shown by a single button.

ZONE 9 through ZONE 16 are only displayed; they have no buttons.

⑤ **Input channel faders**

When SENDS ON FADER mode is on, the faders and [ON] buttons are shown in the same color as the send-destination matrix bus select buttons.

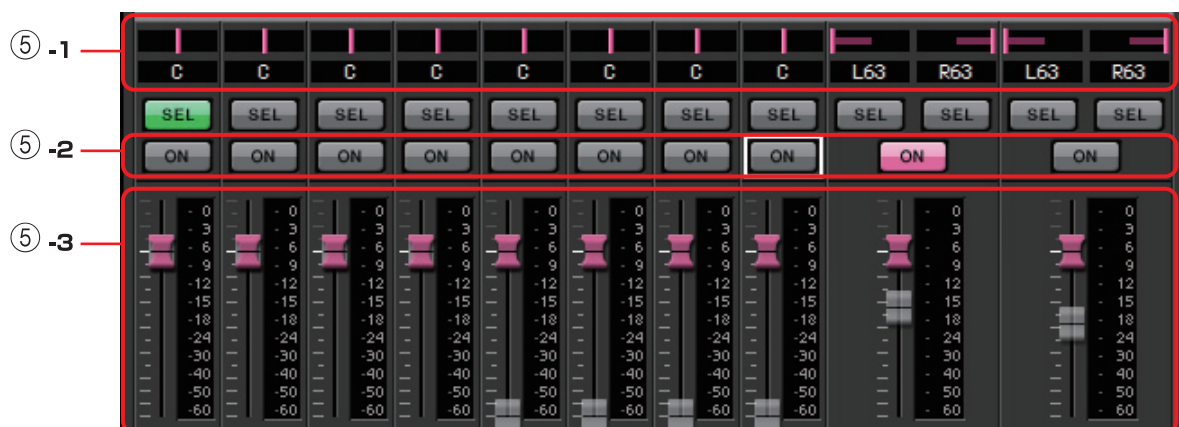

⑤ -1 **PAN (controller and numeric box)**

The controller and numeric value are shown only if the matrix bus is stereo, allowing the setting to be edited.

Far left is 63L, center is C, and far right is 63R.

**NOTE**

- When sending from a stereo input to a stereo bus, you can use "MTX Configuration" dialog box in the "Advanced Settings" dialog box to switch between PAN and Blend. If Blend is selected, the controller and numeric value are not shown (illustration at right).
- In the numeric box, enter [L63] or [l63] to pan fully left; enter [R63] or [r63] to pan fully right. Enter [C] or [c] to pan to the center.



⑤ -2 **[ON] buttons**

Switch send on/off when SENDS ON FADERS mode is on.

⑤ -3 **Faders**

Adjust the send level of the input channels.

You can right-click a fader and set the send level by selecting 0 dB, -3 dB, -6 dB, or -Infinity. A grayed-out fader is shown at the position of the input level (this cannot be edited).

⑥ **Matrix out faders**

The colors of the faders are linked with the colors of the matrix bus select buttons.

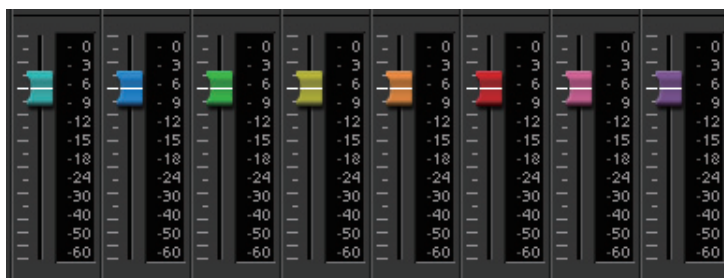

• **Faders**

Adjust the matrix out level.

You can right-click a fader and set the level by selecting 0 dB or -Infinity.

## Setting the input channel mix

1. Click the [SENDS ON FADERS] button.



2. Click a send-destination select button to select a send-destination bus.



3. Adjust the send level of each input channel. You can use the [ON] button to switch send on/off.



# “ZONE” screen

In this screen you can specify settings for the PGM1, and how input signal priority will control output signals.

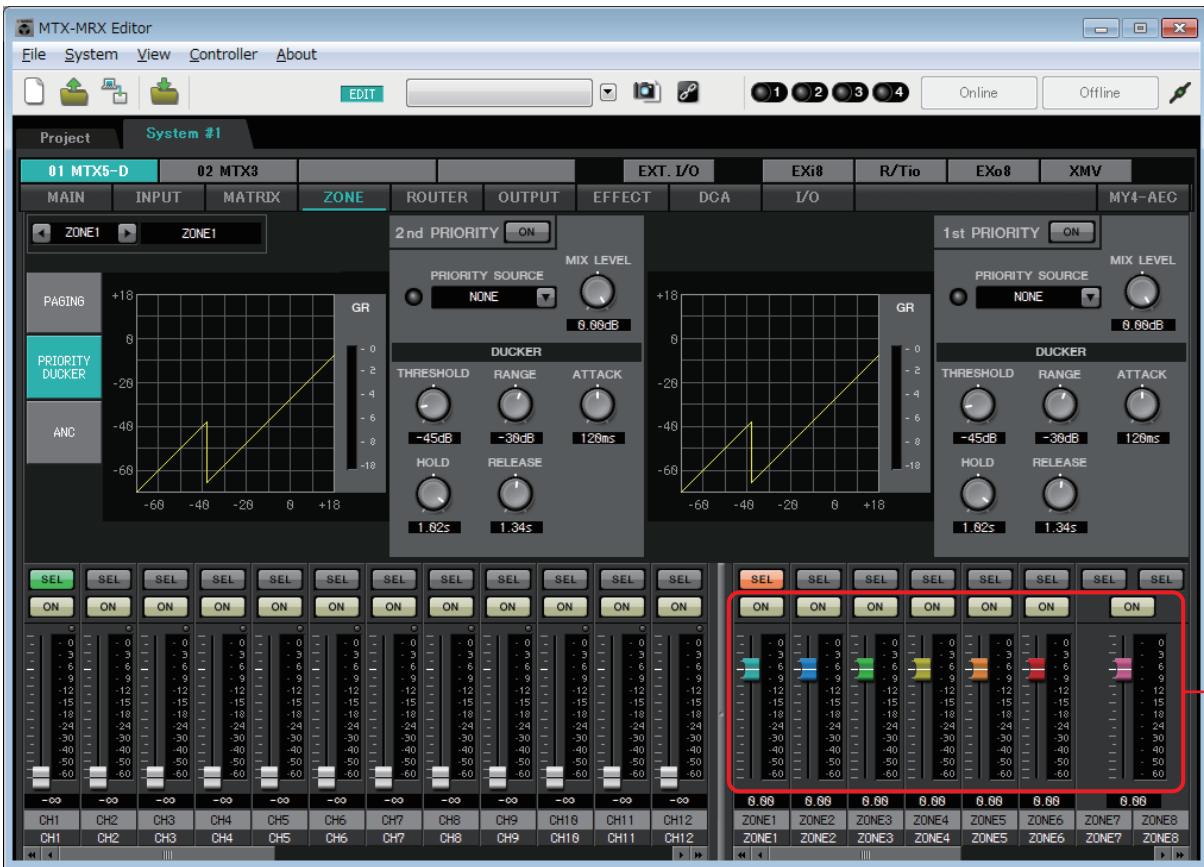

## Signal flow

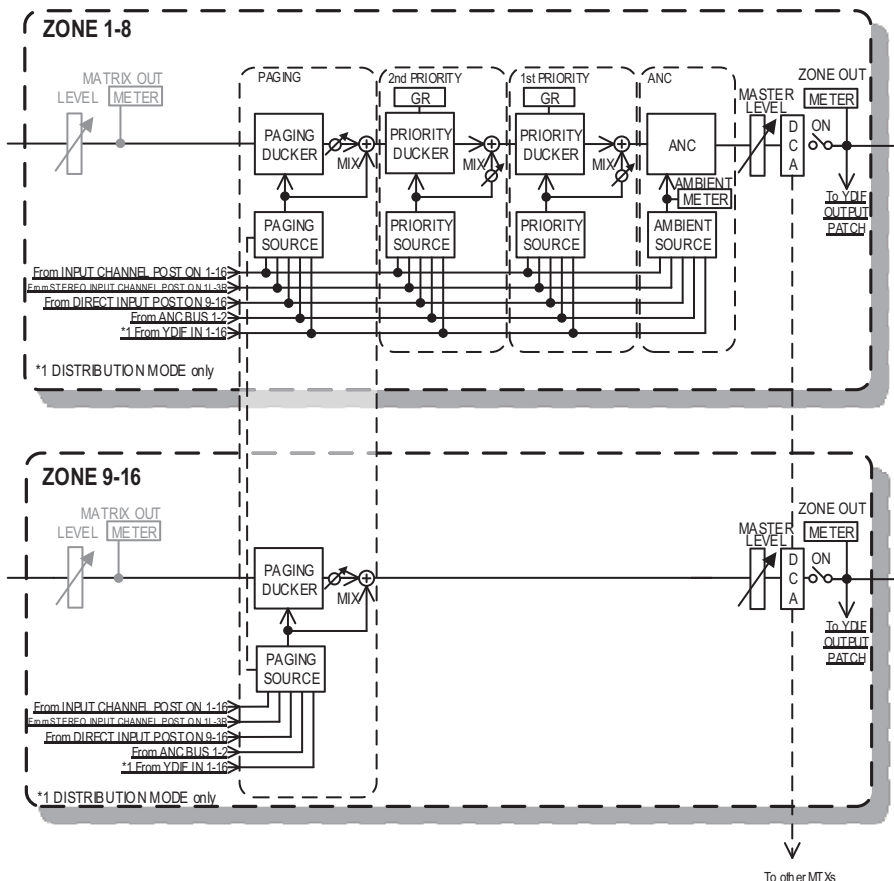

### ① Output channel faders

The colors of the faders are linked with the colors of the [ZONE] buttons in the "MATRIX" screen.

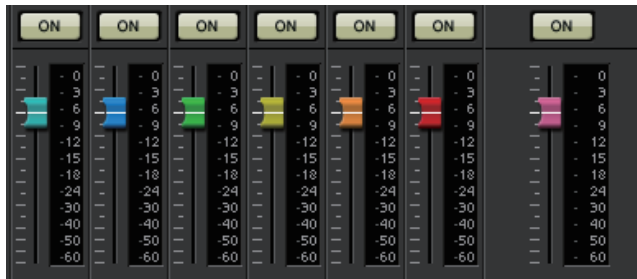

- **[ON] buttons**  
Turn ZONE OUT on/off.
- **Faders**  
Adjust the ZONE OUT level.  
You can right-click a fader knob and set the send level by selecting 0 dB or -Infinity.

### ● Screen selection



By clicking a button, you can switch to the screen for making various settings.

## “PAGING” screen (MTX5-D only)

In this screen you can make settings for the PGM1 paging station microphone.

Paging refers to the function of broadcasting an announcement.

For the workflow of making settings, refer to “[Workflow for paging settings](#)” in the appendix, or the “MTX Setup Manual.”

The SD messages referred to here are standard-format announcements saved on the SD card of the MTX.

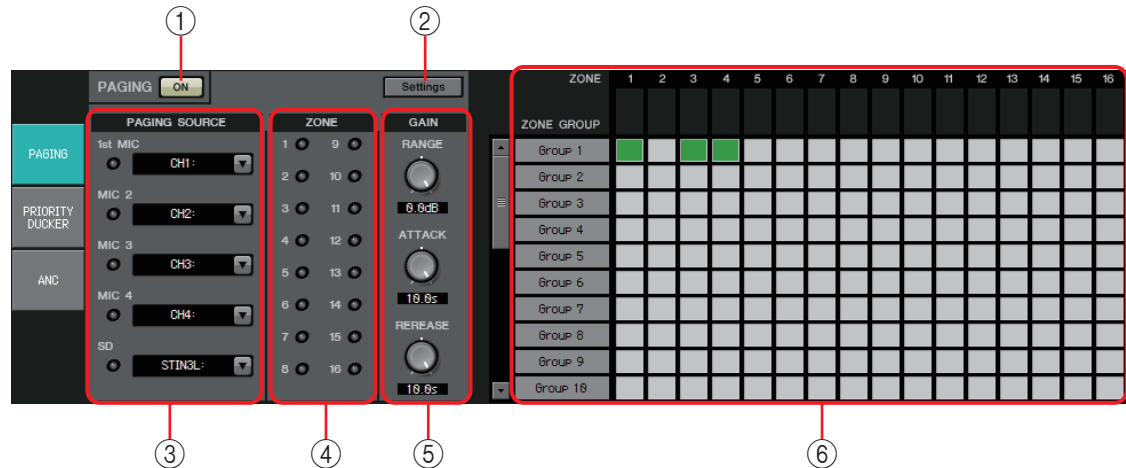

### ① **PAGING [ON] button**

Turns the paging function on/off.

### ② **[Settings] button**

When you click this, the “[PGM1/PGX1](#)” dialog box will appear.

### ③ **PAGING SOURCE settings area**

- **Indicator**  
This is lit if there is a currently-broadcasting PGM1 or SD.
- **Channel list box**  
Selects the paging source. Select the input channel to which a PGM1 or SD is connected. Specify 1st Mic for the input channel of the PGM1 that is specified as 1st Priority.

### ④ **ZONE area**

- **Indicator**  
This is lit if there is a zone that is currently broadcasting using a PGM1 or SD message.

### ⑤ GAIN setting area

Each knob resets to the default value if you click it while holding down the <Alt> key. In this area, you can make settings related to the line shown in green in the flow depicted below.

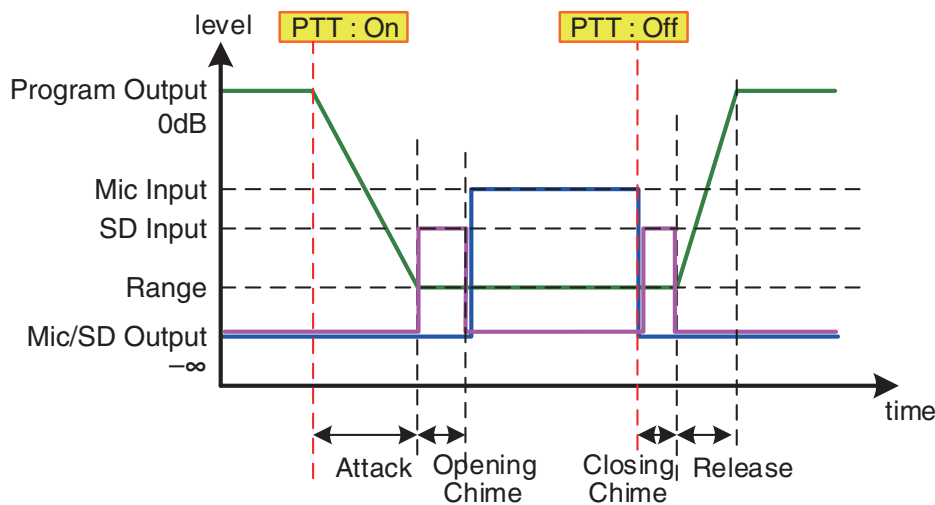

- **[RANGE] knob**  
Specifies the Program value while the chime is sounding or while the PGM1 is broadcasting.
- **[ATTACK] knob**  
Specifies the time from when the PGM1's PTT turns on until the program decreases to the RANGE value.
- **[RELEASE] knob**  
Specifies the time from when the broadcast or the closing chime finishes playing until the program returns to its original level.

### ⑥ ZONE GROUP area

- **Zone name**  
Indicates the zone name specified for the OUTPUT fader below.
- **Group name**  
Indicates the group name. You can double-click this and edit it.
- **ZONE GROUP matrix**  
Specify a zone group if you want a single zone/message select button of a PGM1/PGX1 to broadcast to multiple zones. Click an intersection in the matrix to turn it on/off. Zones that are colored green belong to a zone group. You can specify up to 24 zone groups.

## “PRIORITY DUCKER” screen

In this screen you can make ducker settings.

The ducker is a function that temporarily reduces the input from one channel when an audio signal is input to another specified input channel, allowing the audio from the specified channel to be heard clearly. The priority order is as follows: “PRIORITY SOURCE” of the “1st PRIORITY” > “PRIORITY SOURCE” of the “2nd PRIORITY” > MATRIX Out signal.

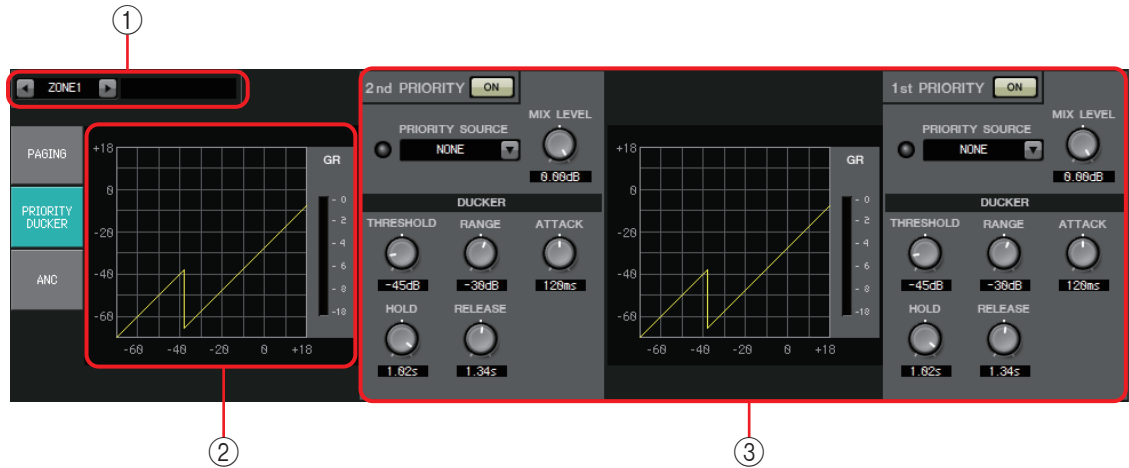

### ① ZONE select buttons

Use the left and right buttons to select the zone for which to make settings.

The name of the zone is shown at the right.

**NOTE** You can also use the output channel [SEL] buttons to select a zone.

### ② Graph and GR meter

This graph shows the ducker settings. The amount of gain reduction applied by the ducker is shown at the right of the graph.

### ③ Ducker setting area

**HINT** Ducker settings can be copied between 1st/2nd, or to another zone. When you right-click within the copy-source settings area, a list will appear.

- **DUCKER [ON] button**  
Turns the ducker on/off.
- **[PRIORITY SOURCE] list**  
Selects the input signal for the ducker.

**NOTE** Select [ANC Bus] if you want the mixed signal to be the high-priority audio. The mix of audio signals to the ANC bus can be created in the “MATRIX” screen.



- **DUCKER indicator**  
When the ducker operates, the indicator will light green to indicate operation.
- **[MIX LEVEL] knob**  
Adjusts the amount by which the signal selected in the [PRIORITY SOURCE] list will be mixed into the ducker’s output.
- **[THRESHOLD] knob**  
Specifies the threshold level at which the ducker will take effect.

- **[RANGE] knob**  
Specifies the amount of attenuation applied when the ducker is active.  
This amount specifies how much of the main audio will remain, or whether it will be silenced.
- **[ATTACK] knob**  
Specifies the time from when the priority source input signal exceeds the THRESHOLD until the ducker for the main signal reaches the amount of attenuation specified by the [RANGE] knob.
- **[HOLD] knob**  
Specifies the time from when the input signal falls below the THRESHOLD until the signal begins returning to its original level.
- **[RELEASE] knob**  
Specifies the duration of the wait from when the HOLD time has elapsed until the ducker no longer affects the input signal.

### Making ducker settings

#### Examples of use

**Example 1:** If there is input from a mic while background music is playing, the volume of the background music will automatically decrease.

**Example 2:** In a conference, the voice of a participant is suppressed when there is input from the mic of the chairperson.

#### 1. Patch the background music and the lowest-priority mics to the desired zone.

The volume of this sound will be attenuated when the ducker operates.

The sound being input as the priority source is not patched to the input of the zone.

#### 2. In the ZONE screen, select the zone for which you want to make ducker settings.



#### 3. Click the DUCKER [ON] button.

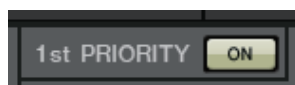

#### 4. In the PRIORITY SOURCE list, select the sound that will have a higher priority than the sounds you patched in step 1.

#### 5. Use [RANGE] to adjust the amount of ducking.

Specify a smaller value if you want some sound to remain as (for example) background music, or specify a high value such as -70 dB if you want the sound to be entirely silenced.

#### 6. Adjust other parameters as necessary.

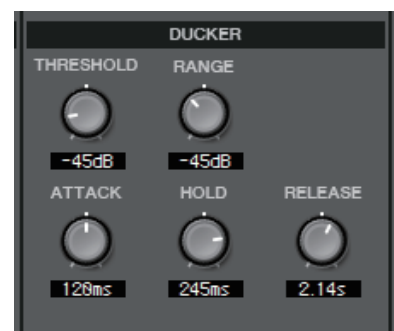

## “ANC” screen

In this screen you can make settings for the “Ambient Noise Compensator” (subsequently called “ANC”).

ANC is a function that boosts or attenuates the output signal from the MTX according to the level that is being input via an ambient noise detection mic. The ANC function provided by the MTX is a gap-type ANC that detects silent intervals such as between songs, detects the noise level during those intervals, and varies the level accordingly.

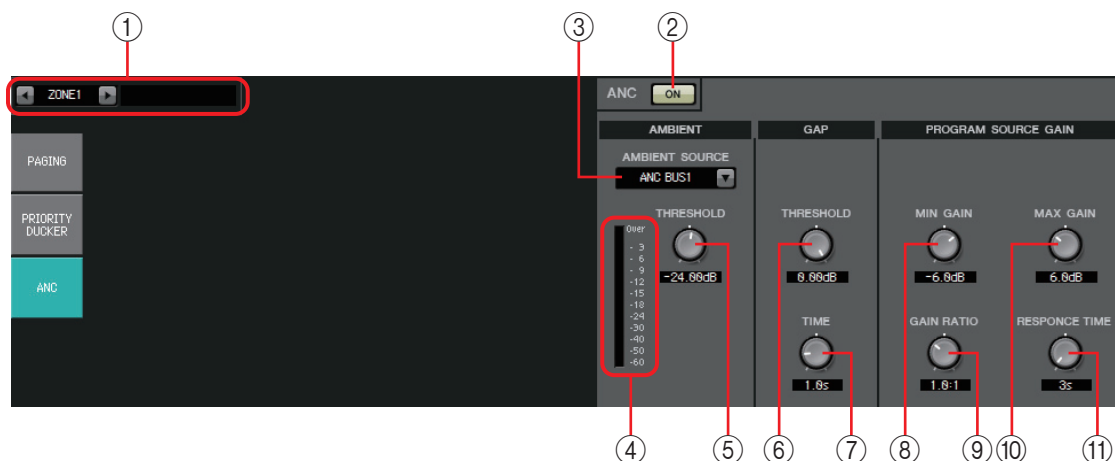

### ① ZONE select buttons

Use the left and right buttons to select the zone for which to make settings.

The name of the zone is shown at the right.

You can also use the output channel [SEL] buttons to select a zone.

### ② ANC [ON] button

Turns ANC on/off.

### ③ [AMBIENT SOURCE] list

Selects the channel to which the ambient noise detection mic is connected.

**NOTE** The mix of audio signals to the ANC bus can be created in the “MATRIX” screen.

### ④ [ANC] level meter

Shows the level of ambient noise.

### ⑤ [AMBIENT THRESHOLD] knob

Specifies the average level of ambient noise.

### ⑥ GAP [THRESHOLD] knob

Specifies the threshold level for the input signal. If the input signal level remains below the threshold for a specified time, it will be interpreted as a gap.

### ⑦ [TIME] knob

Specifies the time required for a gap to be detected.

### ⑧ [MIN GAIN] knob

Specifies the minimum amount by which the input signal level will be compensated.

### ⑨ [GAIN RATIO] knob

Specifies the ratio by which the input signal level will be compensated.

- ⑩ **[MAX GAIN] knob**  
Specifies the maximum amount by which the input signal level will be compensated.
- ⑪ **[RESPONSE TIME] knob**  
Specifies the response speed for level compensation.

**Making ANC settings**

**Examples of use**

**Example 1:** In a location where a speech is being given, automatically adjust the volume of the zone up or down according to the level of ambient noise (e.g., crowd noise).

**Example 2:** In a restaurant, adjust the background music according to the noise of the surrounding conversation in order to maintain privacy.

**1. Set up a mic in a position where it can detect the ambient noise at an appropriate level.**

Place the ambient noise detection mic in a location where it will not receive direct sound from the speakers but will be close to the source of the ambient noise, such as on the ceiling in the middle of the room above the crowd or audience, and at a distance from the speakers.

**2. Select a zone.**



**3. Click the ANC [ON] button.**



**4. In the AMBIENT SOURCE list, select the input signal from the ambient noise detection mic.**

If you've connected more than one mic for detecting ambient noise, select [ANC BUS1/2].

**5. Adjust the ANC threshold setting.**



**6. Adjust the parameters.**



# “ROUTER” screen

In this screen you can assign zone outputs to output channels.

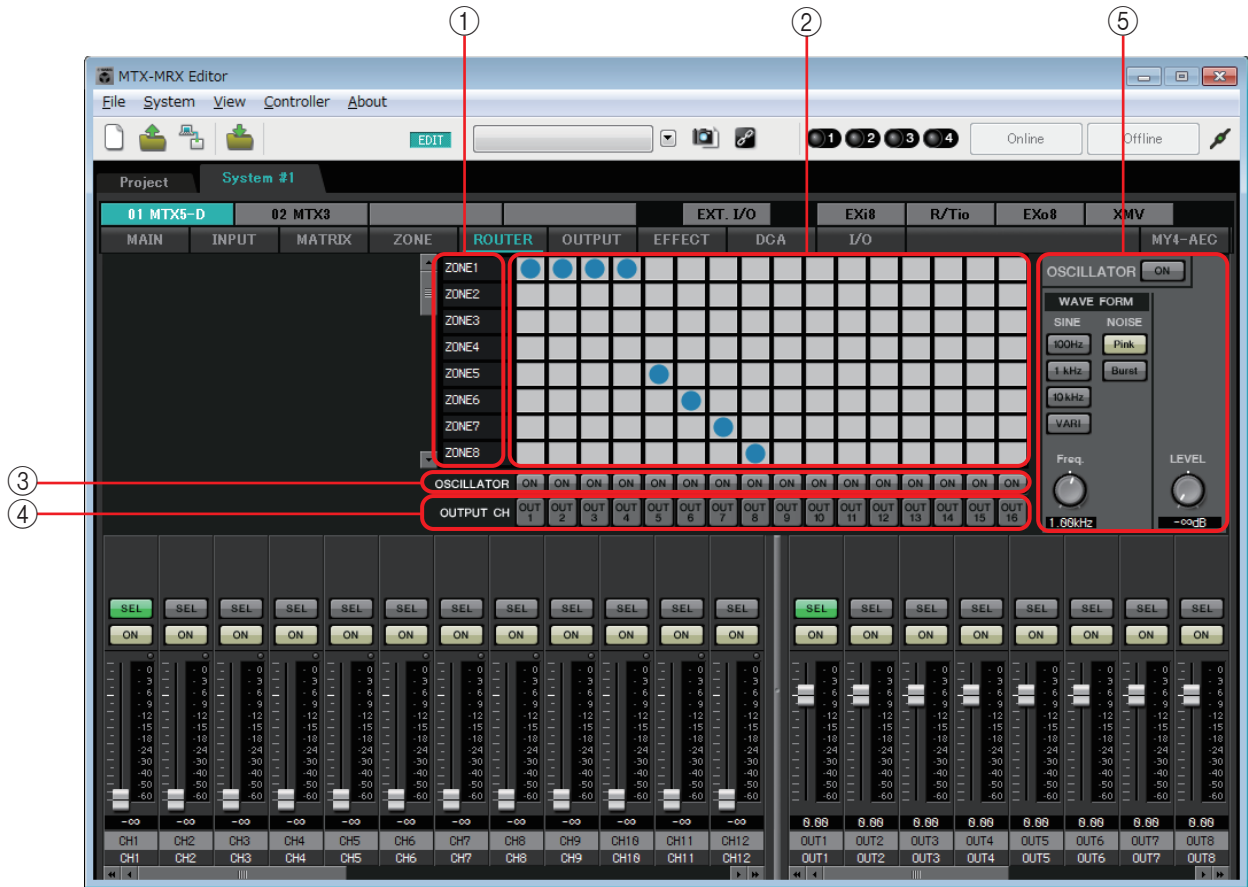

## Signal flow

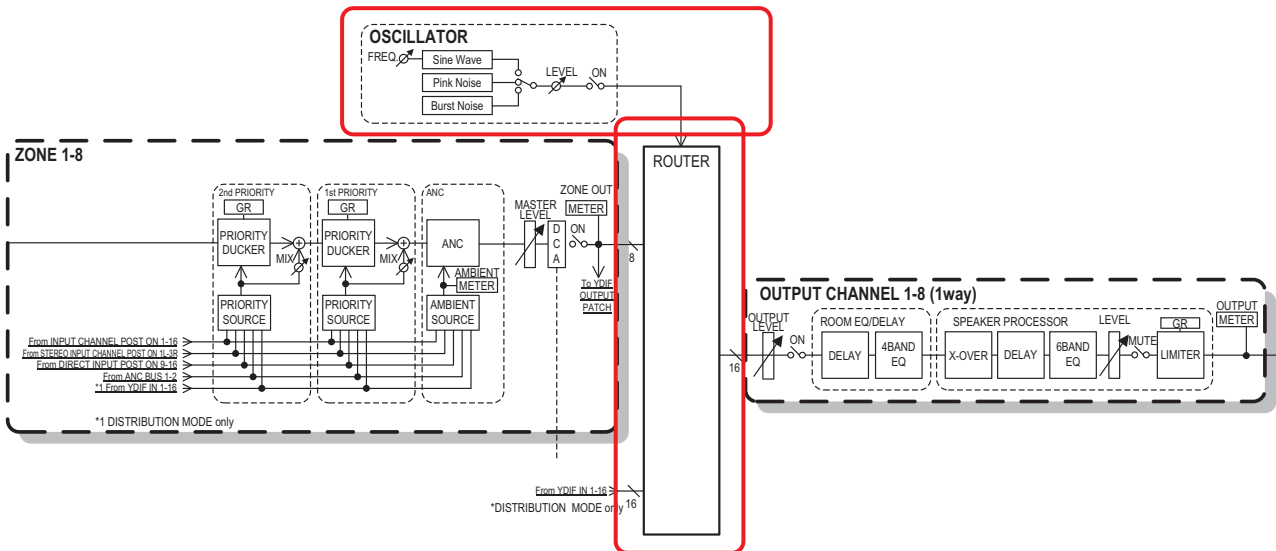

You'll assign zone outputs, YDIF input signals in Distribution mode, and oscillator signals to the output channels.

### ① Input signals to the router

This area shows zone outputs and YDIF signals.

## ② Router

This router distributes the signals. Click a square in the grid to switch the output on/off. If you right-click, a context menu will appear, allowing you to choose [All OFF] to turn all outputs off.

On:  Off: 

It is not possible to mix multiple zone outputs for output to a single output channel.

## ③ OSCILLATOR [ON] button

If this is on, a oscillator signal will be output to the corresponding channel.

However, no signal will be output unless the OSCILLATOR [ON] button at the right is turned on.

## ④ OUTPUT CH [OUT] button

Accesses the CHANNEL EDIT screen of the output-destination channel.

## ⑤ OSCILLATOR setting area

- **OSCILLATOR [ON] button**

If this is on, a oscillator signal will be output.

- **WAVE FORM**

- **[SINE] signal frequency setting buttons**

Specify the frequency of the sine wave that is output by the oscillator.

Choose [100Hz], [1 kHz], [10kHz], or [VARI].

- **Sine wave signal [Freq] setting knob**

Adjusts the output frequency of the sine wave. This is available if you click the sine wave [VARI] button.

- **[NOISE] signal setting buttons**

Choose [Pink] noise or [Burst] noise.

- **Output [LEVEL] knob**

Adjusts the level of the signal that is output from the oscillator.

# “OUTPUT” screens

In these screens you can apply signal processing to the output channels.

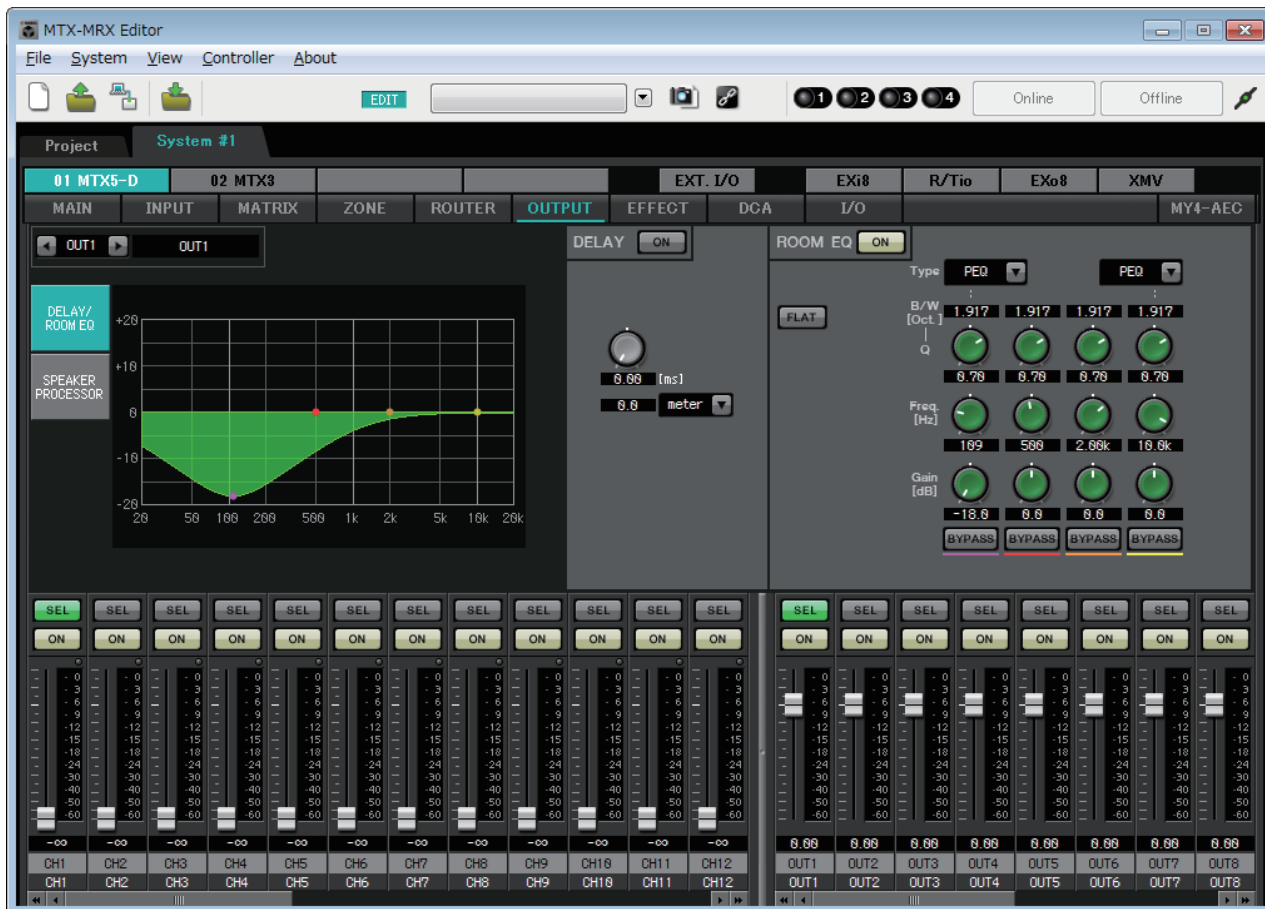

In this screen you can apply signal processing to the output channels. You can apply DELAY/ ROOM EQ, and SPEAKER PROCESSOR.

### ● Channel selection

Left button      Right button

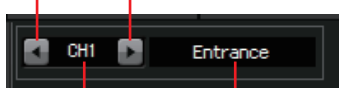

Channel index      Channel name

Use the left or right button to select the channel to which you want to apply signal processing.

### ● Screen selection

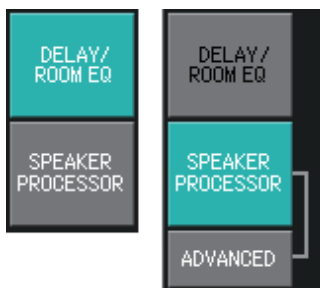

Click the appropriate button to select the screen that includes the channel processing you want to apply.

● **Operations common to the “OUTPUT” screens**

For details on the knobs and numeric boxes, refer to [Explanation of basic operation](#).

**HINT** You can copy channel settings to other channels. When you right-click within the area, a list box will appear. Select a channel, and paste the settings.



The signal from the router is processed by ROOM EQ and SPEAKER PROCESSOR.

Depending on the OUTPUT CHANNEL SETUP setting (1WAY or 2WAY) in the “MTX Configuration” dialog box, the signal routing will differ as follows. If this is set to 2WAY, you will be unable to set “DELAY” or “ROOM EQ” in the screens of even-numbered channels.

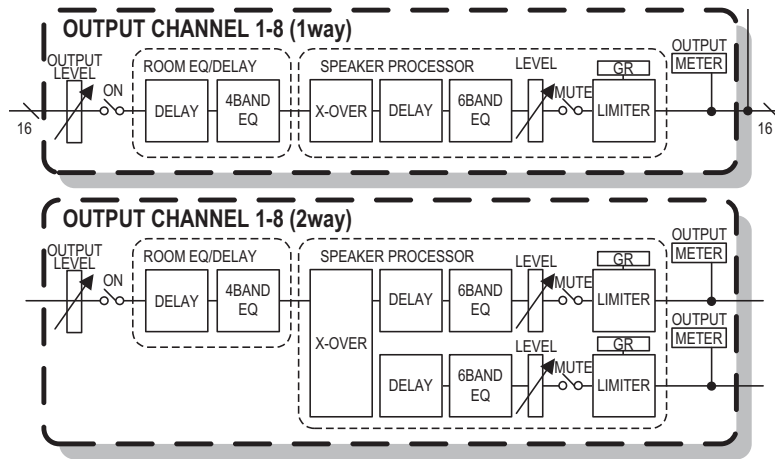

“**DELAY/ROOM EQ**” screen

In this screen you can adjust the DELAY and ROOM EQ parameters.

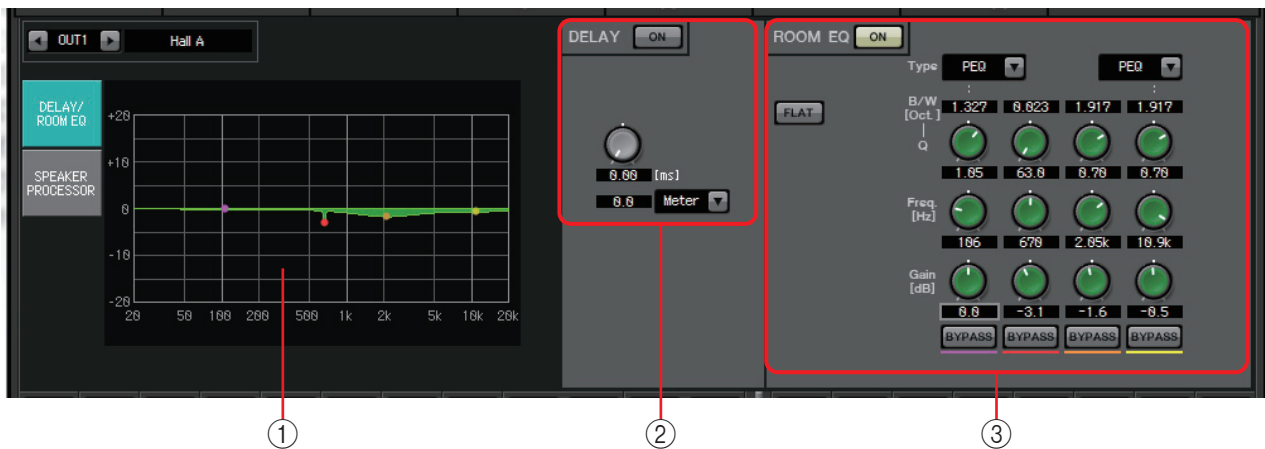

① **ROOM EQ graph**

The effect of the room EQ is shown by this graph. You can drag a control point to edit the parameters.

② **DELAY setting area**

In a sound system that includes multiple speaker units, it may appear to a listener that the voice of the person talking is originating from a nearby speaker unit, rather than from the person themselves. In such cases, you can correct the perceived localization by delaying the audio to the distant speaker unit according to the distance between the speaker unit and the person who is talking.

If sound from different speaker units is mutually interfering, adding a slight delay to one of the audio signals will shift the interfering frequencies, lessening the unnatural sensation.

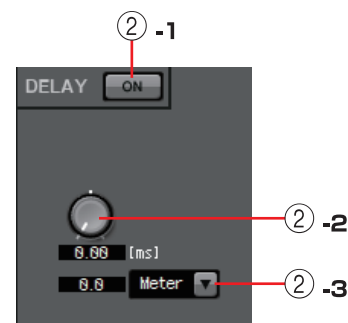

② -1 **DELAY [ON] button**

Turns delay on/off.

② -2 **Delay Time knob**

Specifies the delay time.

② -3 **Type list box**

The delay time specified by the Delay Time knob is converted into the units you select, and shown at the left.

- ms** ..... Milliseconds
- Sample** ..... Number of samples (the range will depend on the sampling frequency setting)
- Meter** ..... Meters/second
- Feet** ..... Feet/second

③ **ROOM EQ setting area**

The sound from the speakers is affected by the materials of the walls, ceiling, and floor, and by the position of the speakers and how they are attached. This four-band EQ lets you compensate for such changes. It cannot compensate for dips in the frequency response that are caused by the shape of the room.

- **ROOM EQ [ON] button**  
Turns the ROOM EQ on/off.

For details on adjusting the following parameters, refer to EQ in [“GAIN/HPF/EQ” screen](#).

- [FLAT] button
- [Type] list box
- [B/W] box
- [Q] knob
- [Freq.] knob
- [Gain] knob
- [BYPASS] button

## “SPEAKER PROCESSOR” screen

In this screen you can view the response of the “SPEAKER PROCESSOR” parameters that are provided for adjusting the speakers; these parameters include APF (All Pass Filter), Horn EQ, and limiter. These parameters can be edited in the “ADVANCED” screen.

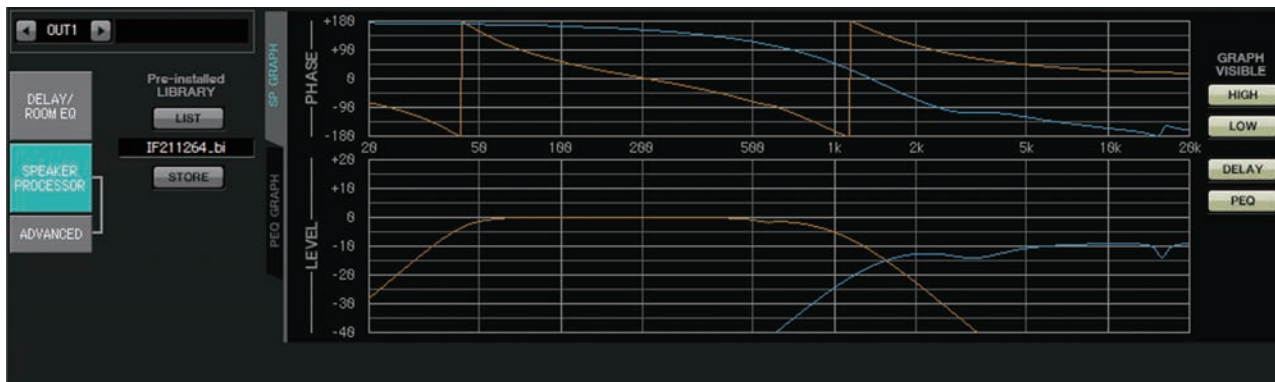

### ■ Pre-installed LIBRARY

In the libraries that are preinstalled with MTX-MRX Editor, the limiter’s threshold value is the value when using a power amp whose voltage gain is 26 dB.

As necessary, you should adjust settings such as the MTX’s limiter settings and output level, and the power amp’s voltage gain and attenuator.

For example if you’re using a power amp with a voltage gain of 30 dB, you should either lower the power amp’s attenuator value by 4 dB, or lower the MTX’s limiter threshold value by 4 dB.

The voltage gain will differ depending on the type and settings of the XMV. For details, refer to the XMV’s user manual.

- **[LIST] button**  
Selects and shows library items.
- **[STORE] button**  
Saves the current state as a library item (file extension [.ce3]).

### ■ [SP GRAPH] tab

#### PHASE

Displays a crossover phase response curve. This display takes into account the response of the PEQ and the Delay.

If the signal type is 2-way, High and Low are displayed separately in different colors.

#### LEVEL

Displays a crossover amplitude response curve. This display takes into account the response of the PEQ and the Output Level.

If the signal type is 2-way, High and Low are displayed separately in different colors.

#### GRAPH VISIBLE

- **[HIGH] button (shown only if the signal type is 2-way)**  
Switches the High graph between visible and hidden.
- **[LOW] button (shown only if the signal type is 2-way)**  
Switches the Low graph between visible and hidden.

- **[DELAY] button**  
Includes or removes the effect of the delay response from the crossover curve that is displayed.
- **[PEQ] button**  
Includes or removes the effect of the PEQ response from the crossover curve that is displayed.

### ■ [PEQ GRAPH] tab

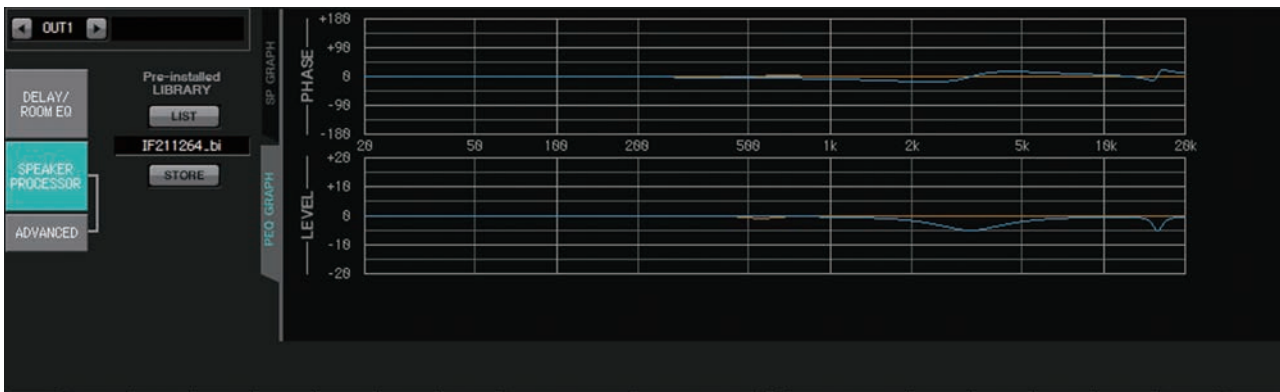

#### PHASE PEQ

Displays the PEQ phase response curve.

If the signal type is 2-way, High and Low are displayed separately in different colors.

#### LEVEL PEQ

Displays the PEQ amplitude response curve.

If the signal type is 2-way, High and Low are displayed separately in different colors.

## “ADVANCED” screen

In this screen you can make detailed “SPEAKER PROCESSOR” settings. If the signal type is 2-way, the parameters are displayed separately for HIGH and LOW.

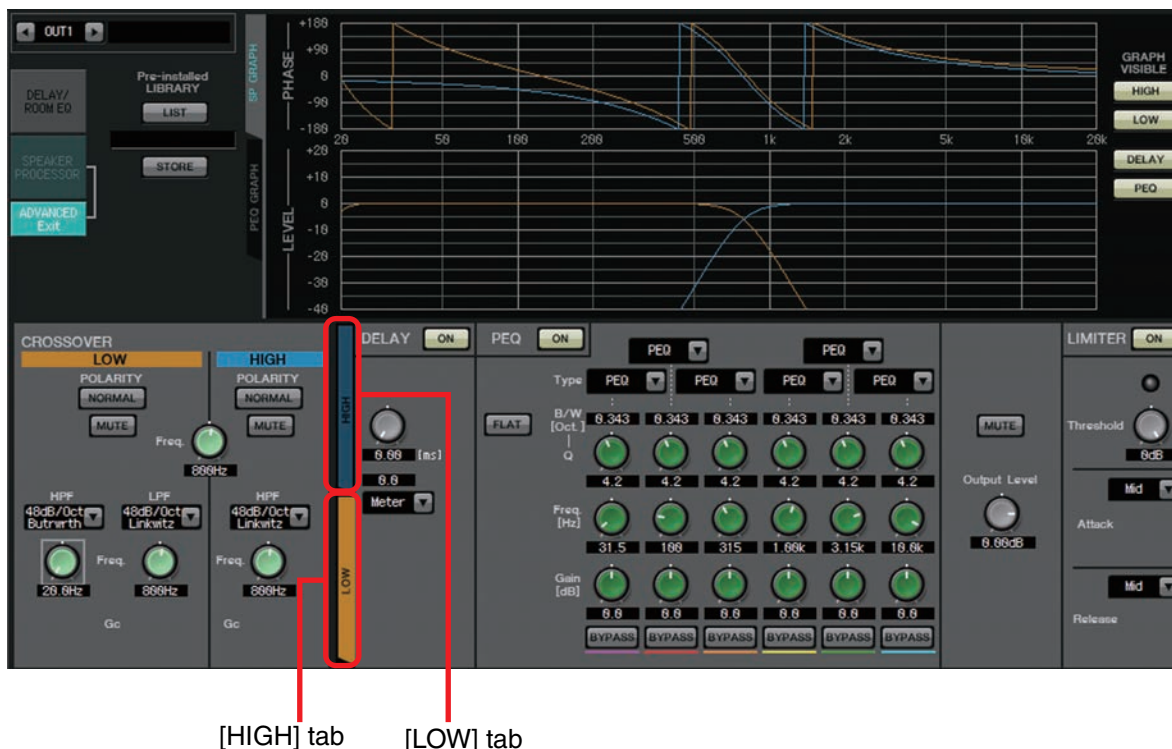

In the “ADVANCED” screen, control points are shown on the LEVEL PEQ amplitude response curve of the “PEQ GRAPH.”

### About the LEVEL PEQ amplitude response curve

If the signal type is 2-way, the High and Low graph displays are linked with your switching between the [HIGH] tab and [LOW] tab.

### ■ CROSSOVER

- POLARITY button**  
 Inverts the phase of the signal that is output from each output channel. Switch between NORMAL/INVERTED.
- [MUTE] button**  
 Mutes the output of each output channel.
- [Freq.] knob**  
 Specifies the crossover frequency of each output channel. If an output channel is muted, its crossover graph is shown as a dotted line.
- HPF/LPF type list box**  
 Specifies the amount of attenuation and the filter type. A menu will appear when you click the list box. You can combine six slopes with four filter types. [6dB/Oct], [12dB/Oct], [18dB/Oct], [24dB/Oct], [36dB/Oct], and [48dB/Oct] specify the amount of attenuation per octave. Lower values apply more gentle attenuation; higher values apply steeper attenuation.

### Thru

No filter will be applied. There will be no attenuation; the response will be the same at all frequencies.

**AdjustGc (Adjustable Gc)**

Adjusts the Gc (gain at the cutoff frequency) in a range of  $-6$  –  $+6$ dB. Setting this to  $-3$ dB will produce a Butterworth filter, and setting this to  $-6$ dB will produce a Linkwitz-Riley filter. The Gc knob will appear when you select this.

**Butrwrth (Butterworth)**

This is the most common response. The passed region is flat, and the gain at the cutoff frequency is  $-3$  dB.

**Bessel**

This curve emphasizes the phase response; the attenuation is more gradual than Butterworth, but the waveform will not be distorted when a square wave is passed through it.

**Linkwitz (Linkwitz-Riley)**

The order of this filter will be a power of two; the summed voltage of the LPF and HPF outputs will produce a gain of 0 dB across the entire frequency range. The passed region is flat, and the gain at the cutoff frequency is  $-6$  dB.

- **HPF/LPF [Freq.] knob**  
Specifies the cutoff frequency of the HPF/LPF.
- **HPF/LPF [Gc] knob (shown only if filter type is set to [AdjustGc])**  
Specifies the gain at the cutoff frequency.

**■ [HIGH] tab/[LOW] tab**

Use the [HIGH] tab and [LOW] tab to switch the [DELAY], [PEQ], [Output Level], [MUTE], and [LIMITER] display.

**■ DELAY**

For details on adjusting the following parameters, refer to [“GAIN/HPF/EQ” screen](#).

- DELAY [ON] button
- Delay Time knob
- [Type] list box

**■ PEQ**

For details on adjusting the following parameters, refer to [“GAIN/HPF/EQ” screen](#).

- PEQ [ON] button
- [FLAT] button
- [B/W] box
- [Q] knob
- [Freq.] knob
- [Gain] knob
- [BYPASS] button
- **[Type] list box**  
Selects the PEQ type.  
The frequency response is shown in PEQ GRAPH.  
For details on the following types, refer to [“GAIN/HPF/EQ” screen](#).
  - PEQ
  - L.SHELF (Low Shelf)
  - H.SHELF (High Shelf)
  - HPF
  - LPF

**APF (All Pass Filter)**

This filter passes the signals of the entire frequency range, affecting only the phase. It is used mainly to correct the phase of the crossover region.

For APF 1st, the phase will be rotated 90° at the specified frequency, and will be rotated in the range 0° to 180° when seen over the entire frequency range. For APF 2nd, the phase will be rotated 180° at the specified frequency, and will be rotated in the range 0° to 360° when seen over the entire frequency range.

**Horn EQ**

A directional horn speaker is characterized by a high frequency level roll-off.

Horn EQ is an equalizer that compensates for this characteristic. For this reason, Gain is restricted to 0 dB or higher and Freq. is restricted to 500 Hz or higher.

- **[MUTE] button**  
Mutes the output.
- **[Output Level] knob**  
Specifies the output level.

**■ LIMITER**

- **[ON] button**  
Turns the limiter on/off. If the button is off, the limiter will be bypassed.
- **Gain Reduction indicator**  
This will light when the threshold value is exceeded.
- **[Threshold] knob**  
Specifies the threshold.
- **[Attack]**  
Specifies the speed at which the limiter will take effect. If Manual is selected, a knob is shown, allowing you to specify the setting in msec units. If Fast/Mid/Slow is selected, the following settings will be made automatically according to the crossover's HPF cutoff frequency in the Speaker Processor settings.  
  - Fast** ..... 1/4 wavelength of the cutoff frequency
  - Mid** ..... 1/2 wavelength of the cutoff frequency
  - Slow** ..... 1 wavelength of the cutoff frequency
- **[Release]**  
Specifies the speed at which the limiter will release. If Manual is selected, a knob is shown, allowing you to specify the setting in msec units. If Fast/Mid/Slow is selected, the following settings will be made automatically according to the crossover's HPF cutoff frequency in the Speaker Processor settings.  
  - Slow** ..... 4 wavelengths of the cutoff frequency
  - Mid** ..... 8 wavelengths of the cutoff frequency
  - Slow** ..... 16 wavelengths of the cutoff frequency

# “EFFECT” screen

In this screen you can change the effect type and edit the effect parameters.

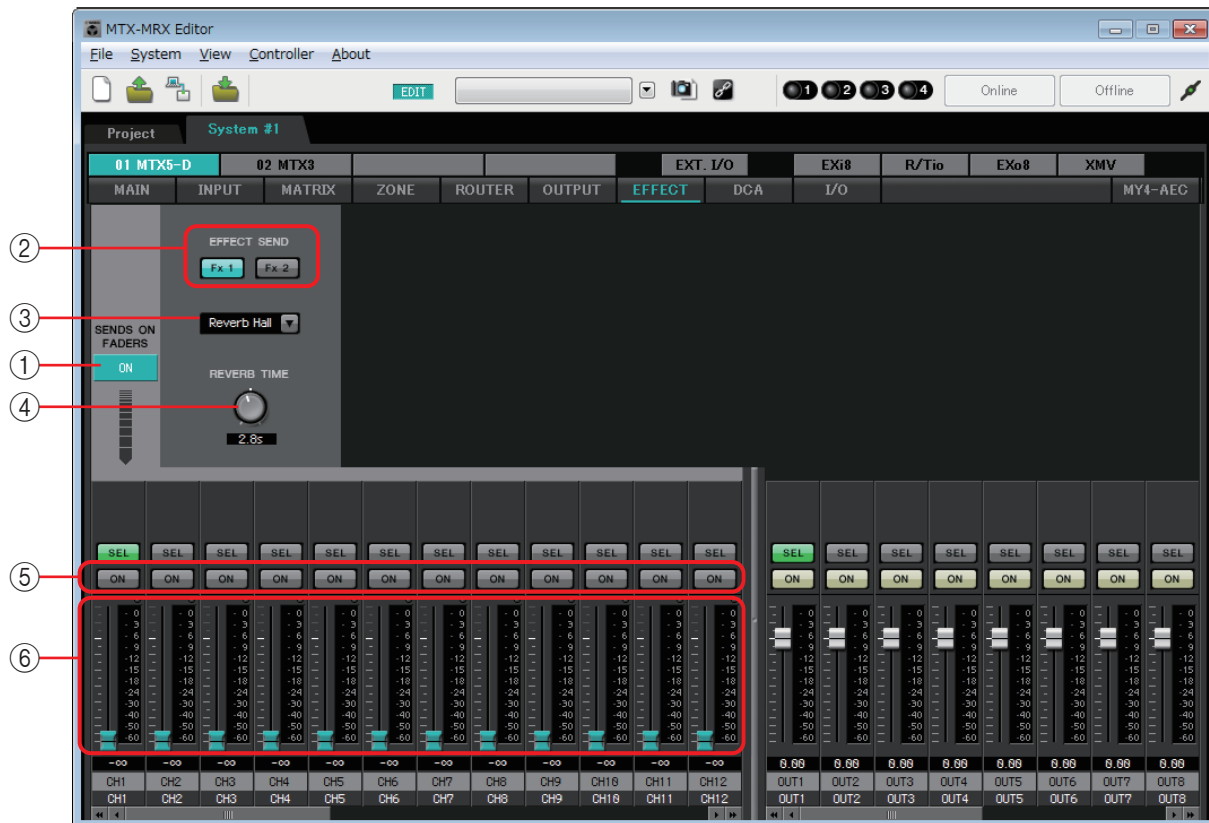

This screen lets you edit the effect that is sent from the input channels to the effect bus. You can specify the type (e.g., reverb or echo), the parameter value for that type, and the send level.

### Signal flow

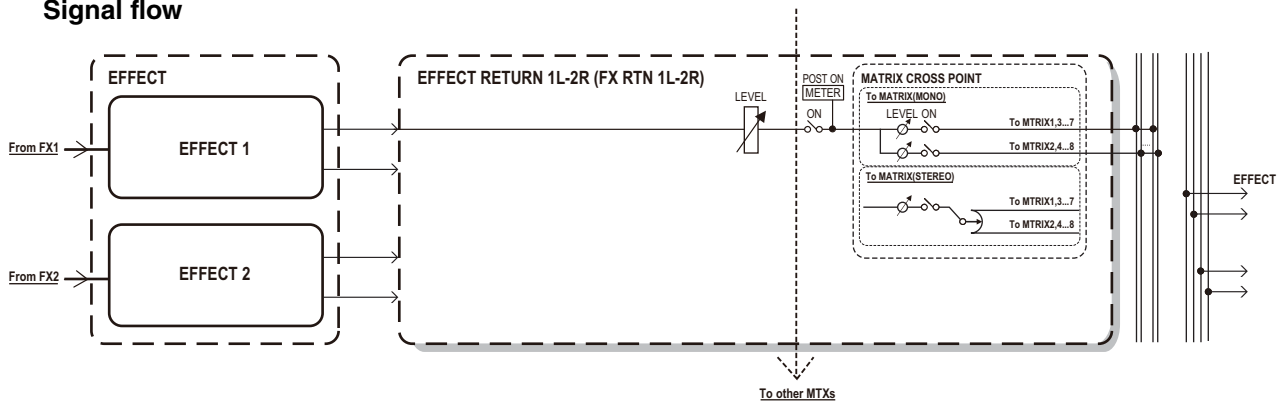

① **SENDS ON FADERS [ON] button**

Turns SENDS ON FADER mode on/off. If this is off, the input channel faders will adjust the input levels.

② **[EFFECT SEND] buttons (available only if SENDS ON FADER mode is on)**

These buttons select the bus to which the effect will be sent. You can select buses [Fx1] or [Fx2].

If you right-click the button, you'll be able to set all send levels in a single operation by choosing 0 dB, -3 dB, -6 dB, or -Infinity.

③ **Effect type (shown only if SENDS ON FADER mode is on)**

This selects the effect type for each bus. You can choose one of the following four types.

- Reverb Hall** ..... Reverb that simulates an expansive space such as a concert hall.
- Reverb Stage** ..... Reverb that simulates a broad stage.
- Karaoke Echo** ..... Echo designed for karaoke use.
- Vocal Echo** ..... Echo designed specifically for stage vocals.

④ **Effect parameter (shown only if SENDS ON FADER mode is on)**

Adjusts the parameter of the effect. This will be [REVERB TIME] if the effect type is reverb, and “DELAY TIME” if the effect type is echo.

⑤ **[ON] button**

Turns the effect send on/off.

⑥ **Faders**

When SENDS ON FADER mode is on, these adjust the effect send levels that are sent from the input channels.

You can right-click a fader knob and set the send level by selecting 0 dB, -3 dB, -6 dB, or -Infinity.

A grayed-out fader is shown at the position of the input level (this cannot be edited).

**Making effect settings**

- 1.** Click the SENDS ON FADERS [ON] button to turn it on.
- 2.** Select the bus ([Fx1] or [Fx2] button) to which the effect will be sent.
- 3.** Select the effect type from the list.

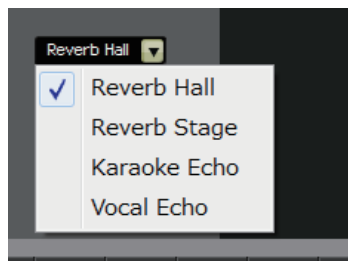
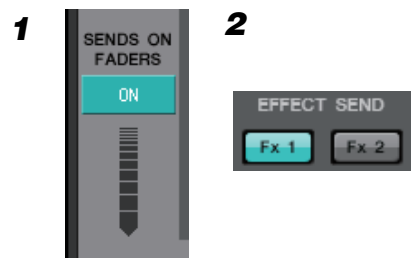

- 4.** Adjust the effect parameter ([REVERB TIME] or [DELAY TIME]).



- 5.** Use the faders to adjust the send level.

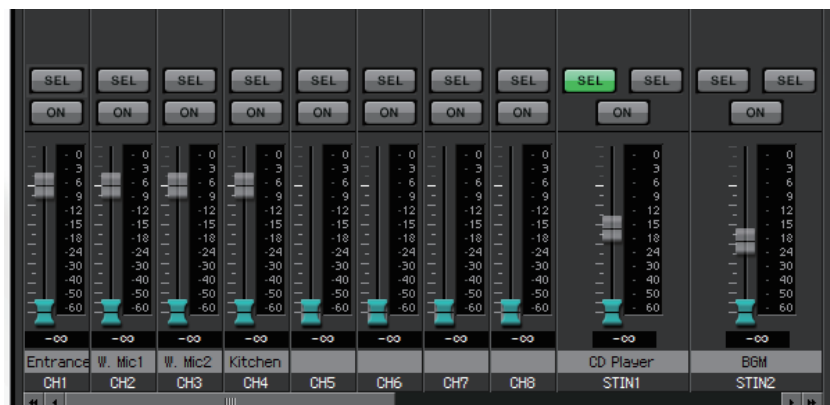

# “DCA” screen

In this screen you can adjust the levels and mute settings of multiple channels.

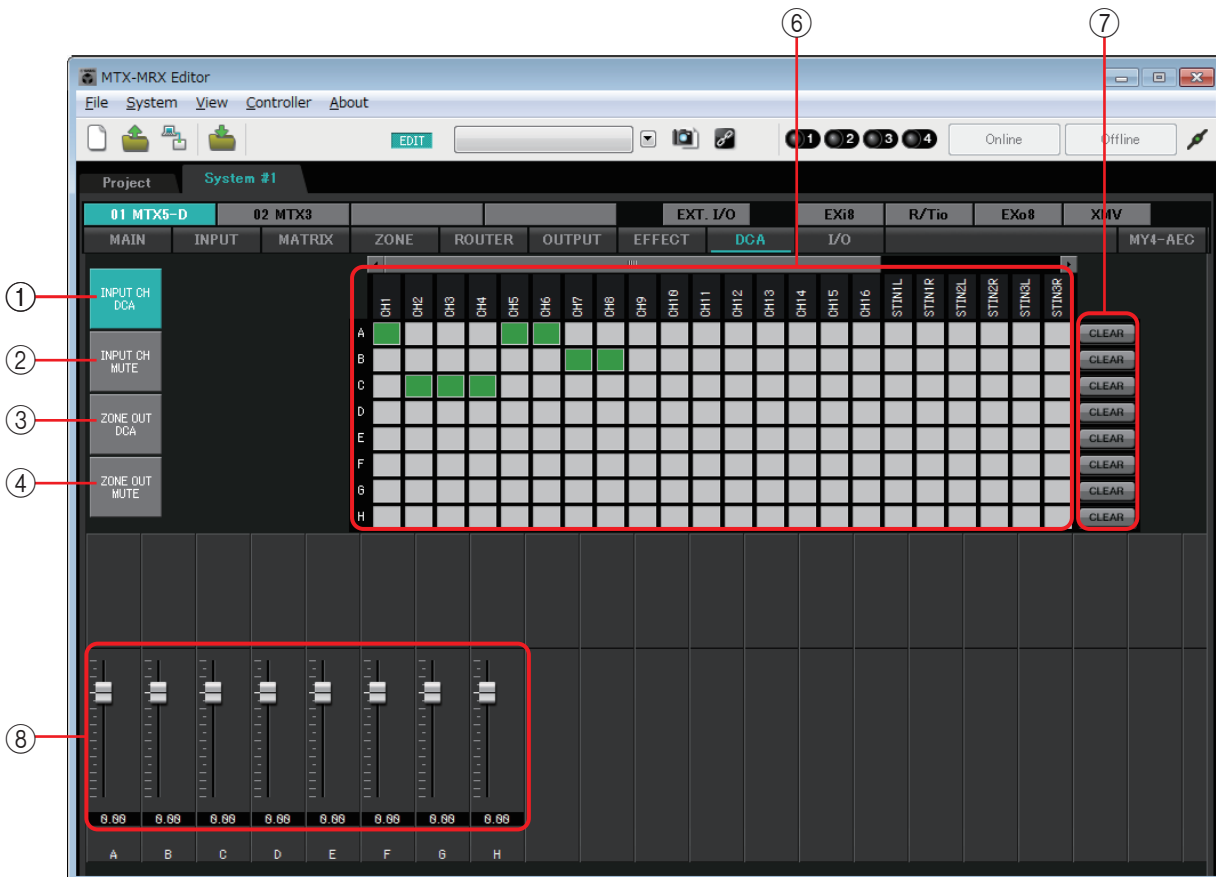

In this screen, input channels can be assigned to eight DCA groups and eight mute groups, and zone outputs can be assigned to eight DCA groups and eight mute groups.

DCA groups allow you to use a single fader to control the input levels or output levels of multiple channels. Mute groups allow you to switch multiple channels on/off together.

Fader settings for DCA groups and [MUTE] group master button settings for mute groups are shared by MTX units within the same MTX/MRX system. For example if you make these settings for the MTX3 whose ID=1, they will automatically be applied to MTX3 units of other ID numbers. This is not shared with MRX units.

- ① **[INPUT CH DCA] button**  
This button selects input channel DCA groups.
- ② **[INPUT CH MUTE] button**  
This button selects input channel mute groups.
- ③ **[ZONE OUT DCA] button**  
This button selects zone output DCA groups.
- ④ **[ZONE OUT MUTE] button**  
This button selects zone output mute groups.

- ⑤ **[MUTE] group master buttons (shown only if the [INPUT CH MUTE] button or [ZONE OUT MUTE] button is selected)**

These buttons turn each mute group on/off.

- ⑥ **Assignment channel matrix**

This matrix lets you assign channels to DCA groups or mute groups.

The group names are shown on the vertical axis, and the names of the channels that can be assigned are shown on the horizontal axis. Click an intersection to assign a channel to a group.

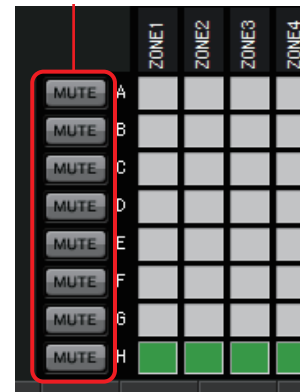

On:  Off:

- ⑦ **[CLEAR] button**

This button clears all channels assigned to the corresponding group.

- ⑧ **Faders (shown only if the [INPUT CH DCA] button or [ZONE OUT DCA] button is selected)**

Adjust the level of each DCA group.

# “I/O” screen

In this screen you can make settings related to the HA (head amp) of the MTX’s analog input, and for the MTX’s digital output.

You can also make settings to specify whether a pilot tone is output from digital output.

When the PILOT TONE [ON] button is on, a pilot tone is output to channels whose digital output’s [PT] button is on.

To specify the XMV units that receive the pilot tone, access the “Project” screen > [Device] tab, and click the [INPUT SOURCE] button to make settings for redundancy.

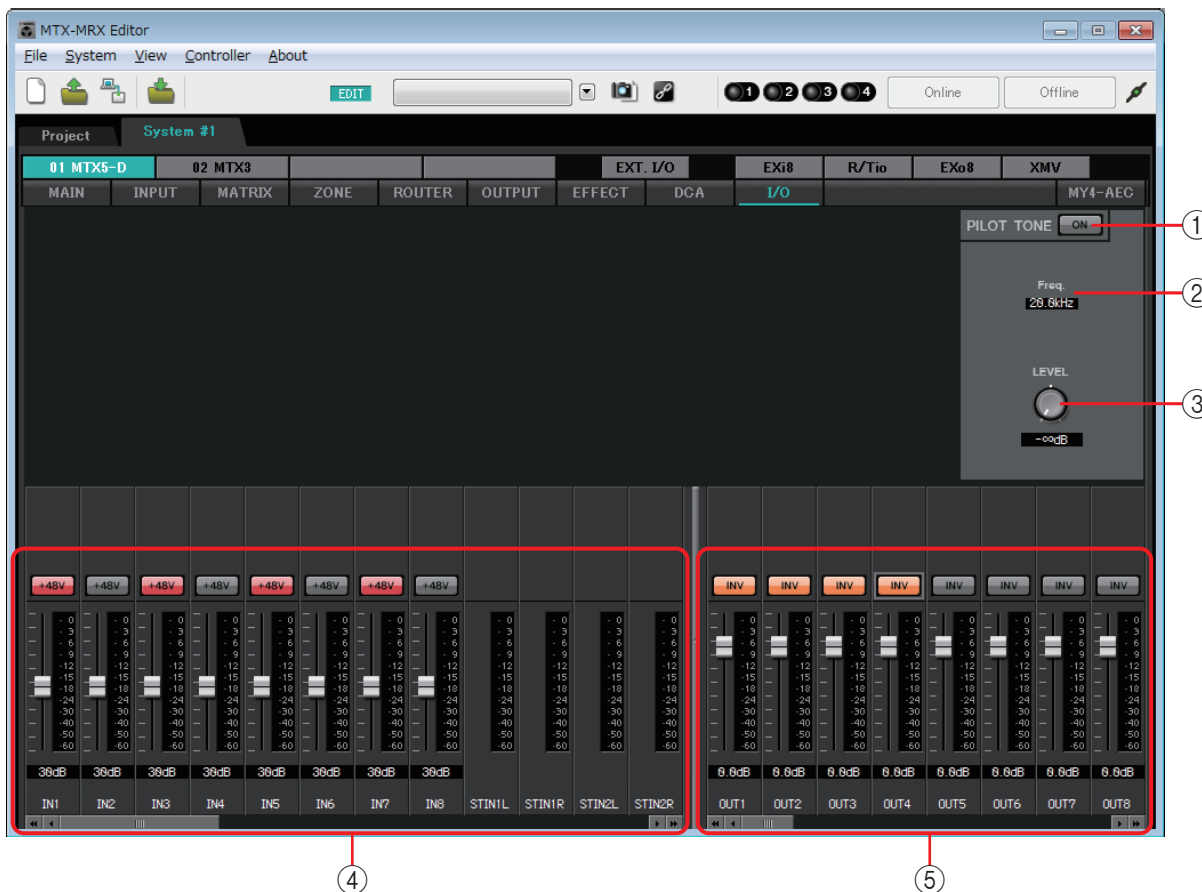

## Signal flow

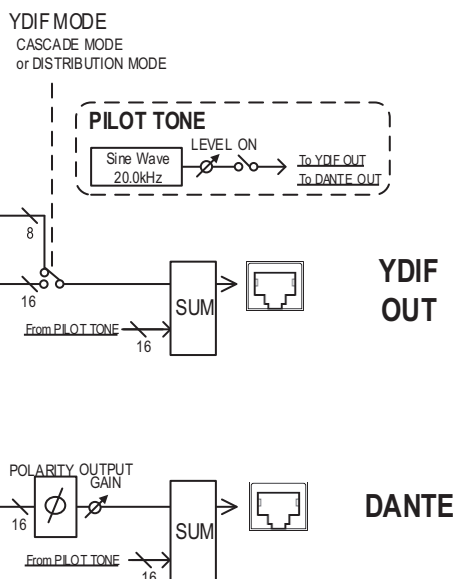
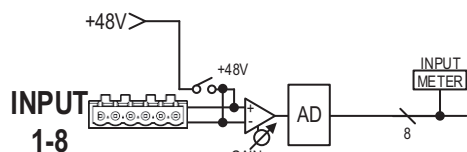

**① PILOT TONE [ON] button**

Turns the pilot tone function on/off. If this is off, a pilot tone is not output even if the [PT] button is on.

**② Freq.**

Indicates the center frequency of the pilot tone. This is fixed at 20 kHz.

**③ [LEVEL] knob**

Specifies the level of the pilot tone.

**④ Analog input settings area**

Here you can make settings for the HA (head amp) of the MTX’s analog input. These settings are linked with the input channel parameter editing screen of the “MAIN” screen.

**• [+48V] button**

Turns the phantom power (+48V) of the HA (head amp) on/off.

**Notice**

**Be sure to leave this button off if you do not need phantom power.**

**Follow the important precautions below, in order to prevent noise and possible damage to external devices as well as the unit when you operate this switch.**

- **Leave this button off if a device that does not support phantom power is connected to the [INPUT] connector.**
- **Do not connect/disconnect a cable to/from the [INPUT] connector while this button is on.**
- **Lower the output level to the minimum before turning phantom power on/off.**

**NOTE** *There is no master switch. To avoid malfunctions, be sure to set this appropriately for the equipment that is connected.*

**• Fader/meter**

Adjusts the analog gain of the HA.

You can right-click a fader knob and set the analog gain by selecting 0 dB or –6 dB.

**⑤ Digital output settings area**

Here you can make settings related to the MTX’s digital output. These settings are linked with the output channel parameter editing screen of the “MAIN” screen.

**• [PT] button**

Turns the pilot tone output on/off. When the PILOT TONE [ON] button is on, a pilot tone is output to channels whose [PT] button is on.

**• POLARITY button**

Switches the polarity of the output signal.

**• Fader/meter**

Adjusts the output gain.

You can right-click a fader knob and set the output gain by selecting 0 dB or –96 dB.

# “MY4-AEC” screen

In this screen you can make settings for the MY4-AEC installed in the MTX5-D’s [SLOT]. This screen will not appear if any other card is installed or if no card is installed.

**NOTE** For example settings, refer to “MTX5-D/MY4-AEC System Setup Manual.”

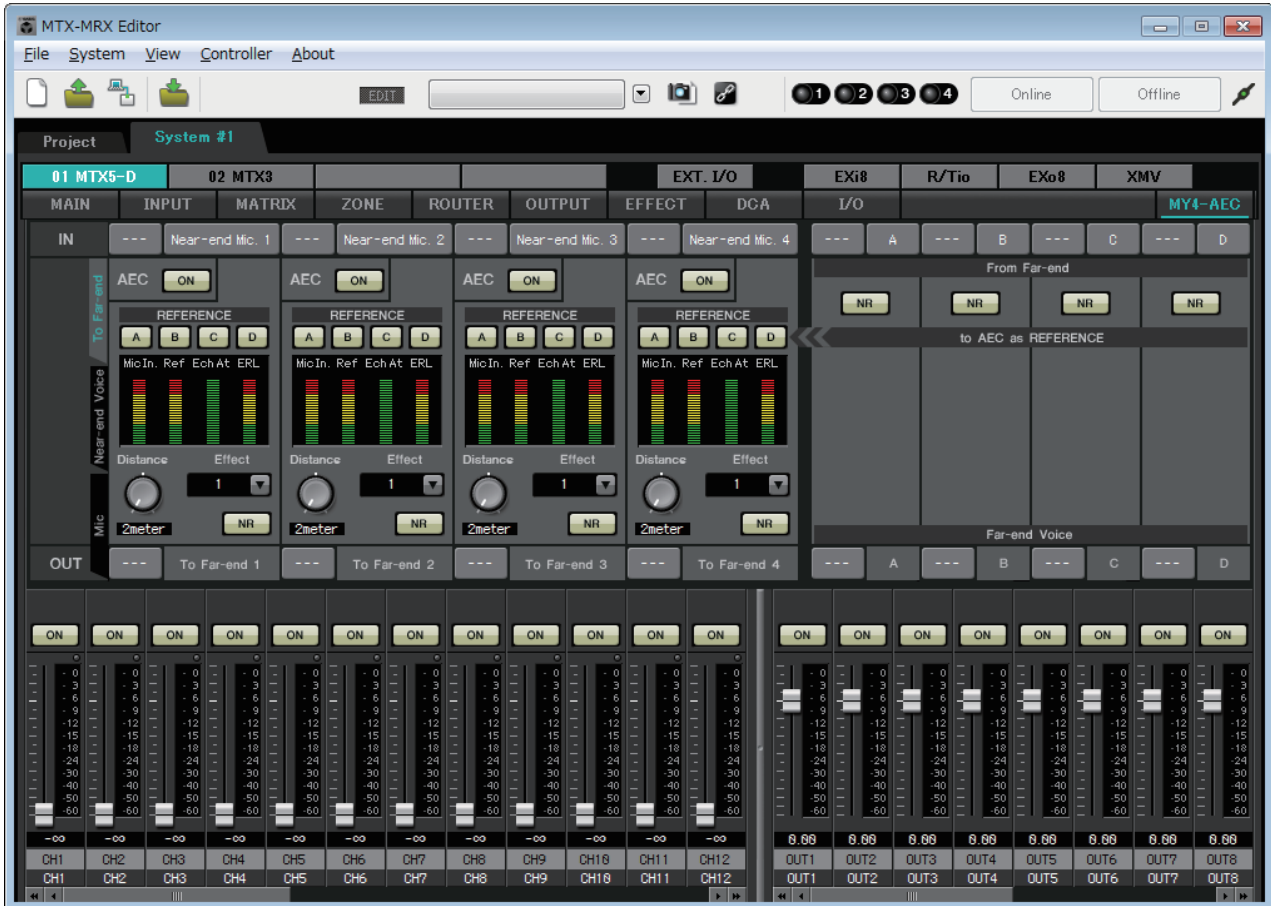

In this screen you can make settings for the signals of the MY4-AEC.

In a teleconferencing system, the local and remote environments are respectively called the Near-end and Far-end.

The MY4-AEC’s acoustic echo canceller (AEC) determines the echo component included in the mic input signal by using the signal from the Far-end as the reference signal, and subtracts only the echo component of the Far-end from the mic input signal. This allows clear audio from the Near-end to be transmitted to the other party.

The MY4-AEC’s signals can be specified using the following choices and screens.

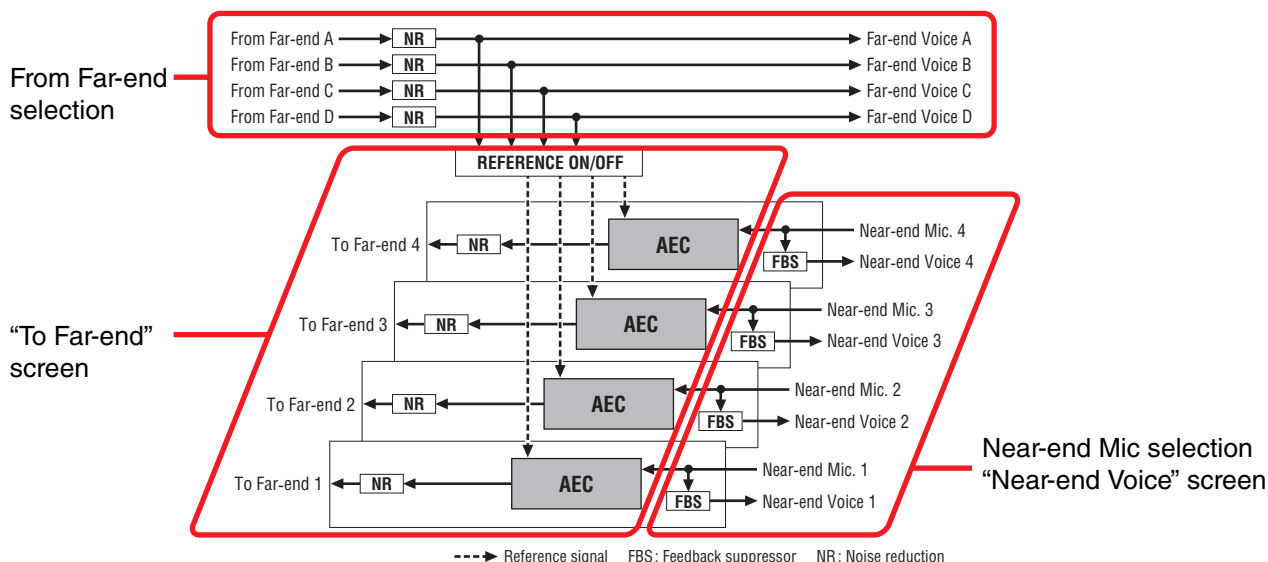

<b>From Far-end</b>	Input signals from the remote location (the other party)
<b>Far-end Voice</b>	Signals from the remote location reproduced by the speakers of the local location (your side)
<b>Near-end Mic.</b>	Input signals from local mics
<b>Near-end Voice</b>	Signals from local mics reproduced by local speakers
<b>To Far-end</b>	Echo-cancelled signals of local mics sent to the remote location

## Common items

Here we explain items that do not change even when the screen changes.

### About input and output

The MY4-AEC inputs audio signals from the ports or output channels of the MTX5-D. The MY4-AEC outputs audio signals to the input channels of the MTX5-D.

### ● Screen selection



Click the appropriate tab to select the screen that includes the channel processing you want to apply.

### ● Near-end Mic selection

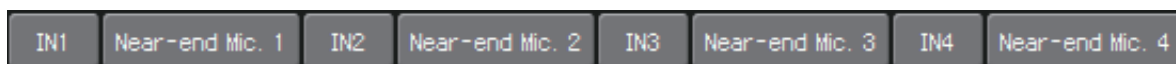

Here you can select the ports for the local mics (Near-end Mic). When you click a port select button, the **“Input Patch” dialog box** will appear. The button shows the currently selected port.

When you click the button located at the right of a port select button, a **Parameter edit screen** will appear as a pop-up.

## ● From Far-end selection



Here you can select the channels to which input signals from the remote location will be output.

### ① [From Far-end] signal selection buttons

These open the “[Input Patch](#)” dialog box, where you can select the audio signals from the remote location (From Far-end). The button shows the currently selected port or channel.

### ② [NR] button

These are on/off switches for the noise reduction function which removes steady-state noise such as produced by a projector or air conditioner in the remote location. We recommend that you leave these on. The audio signal after noise reduction will be the reference signal (REFERENCE).

### ③ [Far-end Voice] selection buttons

These buttons select the output destinations for the audio signals that are output to the speakers of the local location. Click a button to open the “[Output Patch](#)” dialog box. The button shows the currently selected channel.

**NOTE** It is assumed that the Far-end Voice will be mixed with the Near-end Mic and output from the speakers. Therefore as seen from the MY4-AEC, the Far-end Voice is output to an input channel of the MTX.

## □ "To Far-end" screen

In this screen you can make echo-cancel settings for the mics.  
The mic signal after echo-cancellation is output to the remote location.

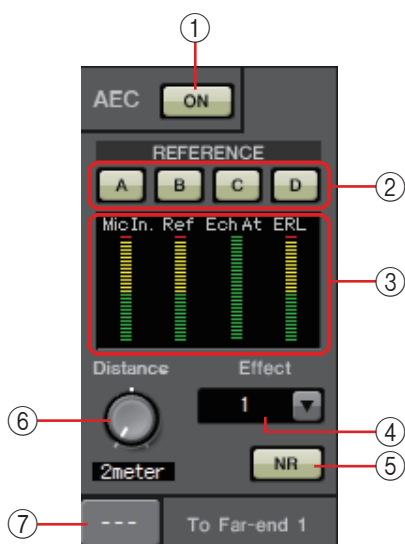

① **AEC [ON] button**

Switches the echo canceller function on/off.

② **REFERENCE [A][B][C][D] buttons**

These buttons select whether the signal specified by the [From Far-end selection](#) will be used as the AEC reference signal (REFERENCE).

If multiple signals are selected, they will be mixed.

③ **Meters**

**Mic In. meter** ..... Indicates the level of the signal that is input from your own mic (Near-end Mic).

**Ref In. meter** ..... Indicates the level of the reference signal. The most effective echo cancellation will be obtained with a level at which the yellow indicators light occasionally.

**Echo Attn. meter**.. Indicates the amount of echo cancellation for each channel. Higher levels indicate that the echo canceller is working.

**ERL meter**..... Indicates the ERL (Echo Return Loss = the level of the audio that is output from the speaker and re-input to the mic). Echo cancellation will work most effectively if you adjust the position of the speaker and mic so as to minimize this level.

④ **[Effect] box**

Specifies the amount of echo cancellation. Higher numeric values allow more echoes to be cancelled. However, the audio quality will decrease correspondingly, so you should consider the balance between these factors as you make the adjustment.

⑤ **[NR] button**

These are on/off switches for the noise reduction function which removes steady-state noise such as produced by a projector or air conditioner in the local location. We recommend that you leave these on.

⑥ **[Distance] knob**

This specifies the distance between the installed mic and speaker in units of meters. If multiple mics and speakers are connected, specify the distance between the mic and speaker that are closest to each other. If the distance is 2 m or less, set this to 2.

⑦ **[To Far-end] channel select button**

This button selects the output destination for the audio signals that are output to the remote location (Far-end). Click the button to open the “Output Patch” dialog box.

□ **“Near-end Voice” screen**

In this screen you can make settings for the FBS (Feed Back Suppressor) that is built into the MY4-AEC.

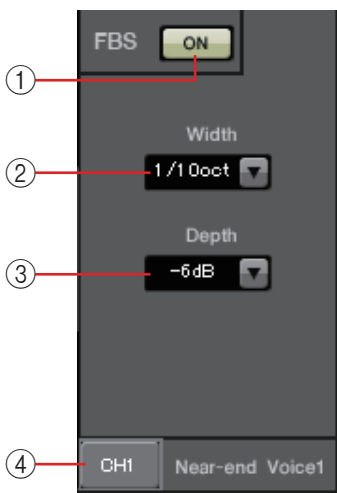

① **FBS [ON] button**

This turns the feedback suppressor function on/off.

The FBS of the MY4-AEC uses the dynamic method of finding the constantly changing feedback points and updating the filter settings accordingly.

This is reset when the MTX5-D is powered-off, and will return to a state in which no notch filter is inserted.

② **[Width] box**

Here you can specify the rejection width of the notch filter that is inserted at the frequency where feedback is detected. Choose a narrower rejection width if the feedback suppressor causes unwanted changes in the character of the sound. A setting of “1/93” is the narrowest setting for the notch filter. However in this case, the feedback suppressor may be less effective.

③ **[Depth] box**

Here you can specify the amount of rejection applied by the notch filter that is inserted at the frequency where feedback is detected. A setting of “-18” produces the strongest suppression of feedback. However in this case, you may notice more change in the character of the sound.

④ **[Near-end Voice] channel select button**

This button selects the output destination for the audio signal that is output locally (Near-end Voice). Click the button to open the “Output Patch” dialog box.

## □ “Mic” screen

When using a mic equipped with a PTT (Push To Talk) switch, a small amount of noise may be heard while the PTT switch is off. If this noise is input to the AEC, the AEC will mistakenly learn the noise, causing an echo when the PTT switch is turned on to resume speaking. In this screen you can make settings and specify the type of mic to prevent this from occurring.

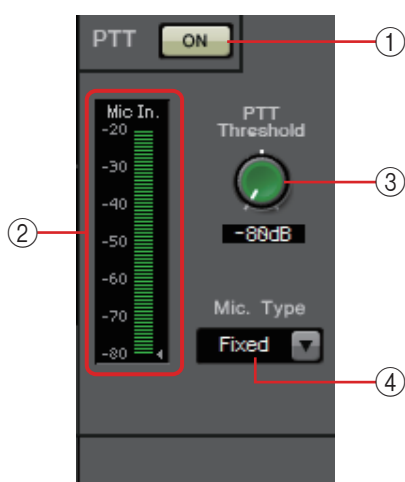
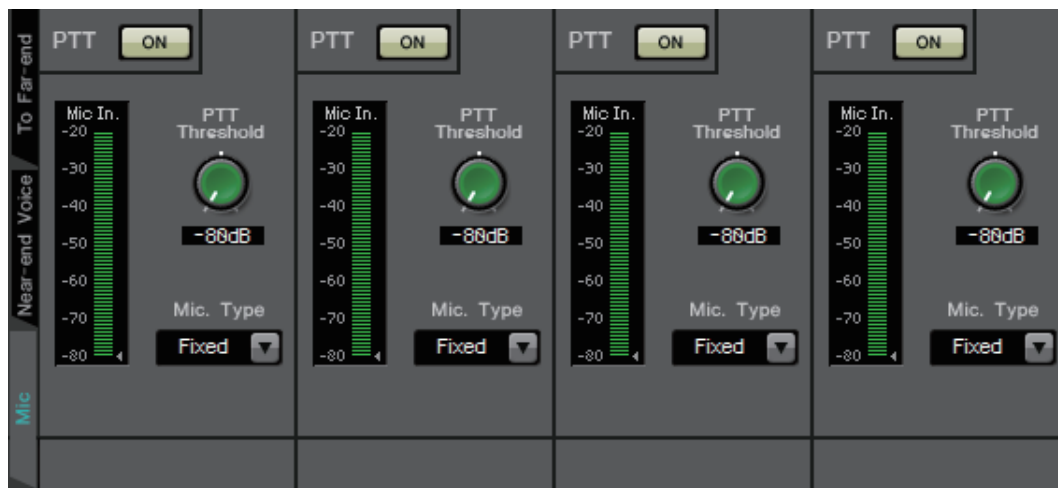

### ① **PTT [ON] button**

If this is on, and the input level from the local mic (Near-end Mic) falls below the value specified in PTT Threshold, the system will determine that the PTT switch of the local mic has been turned off, and will stop AEC learning. We recommend that you leave this on.

### ② **Mic In. meter**

This indicates the level of the signal that is input from the local mic (Near-end Mic). This meter will also indicate the level of the noise that occurs when the PTT button of the mic is off.

### ③ **[PTT Threshold] knob**

This knob sets the reference level for AEC learning. If the PTT [ON] button is on, AEC learning will stop when the input signal to the local mic (Near-end Mic) falls below this level; learning will resume when the input signal exceeds this level. The Mic In. meter indicates the level of the input signal.

### ④ **[Mic. Type] box**

Specify the type of mic that is connected.

Choose “Fixed” for an environment in which the distance between the mic and speaker is fixed, or “Moving” for an environment in which this distance changes, such as when a hand mic is used. Even in an environment in which the distance between the mic and speaker is fixed, choose “Moving” if the echo is obtrusive.

# “EXT. I/O” screen

Here you can select the signal routing for the MTX series and MRX series unit’s YDIF connectors and analog connectors.

## □ “YDIF” screen (Distribution mode)

This screen appears in Distribution mode.

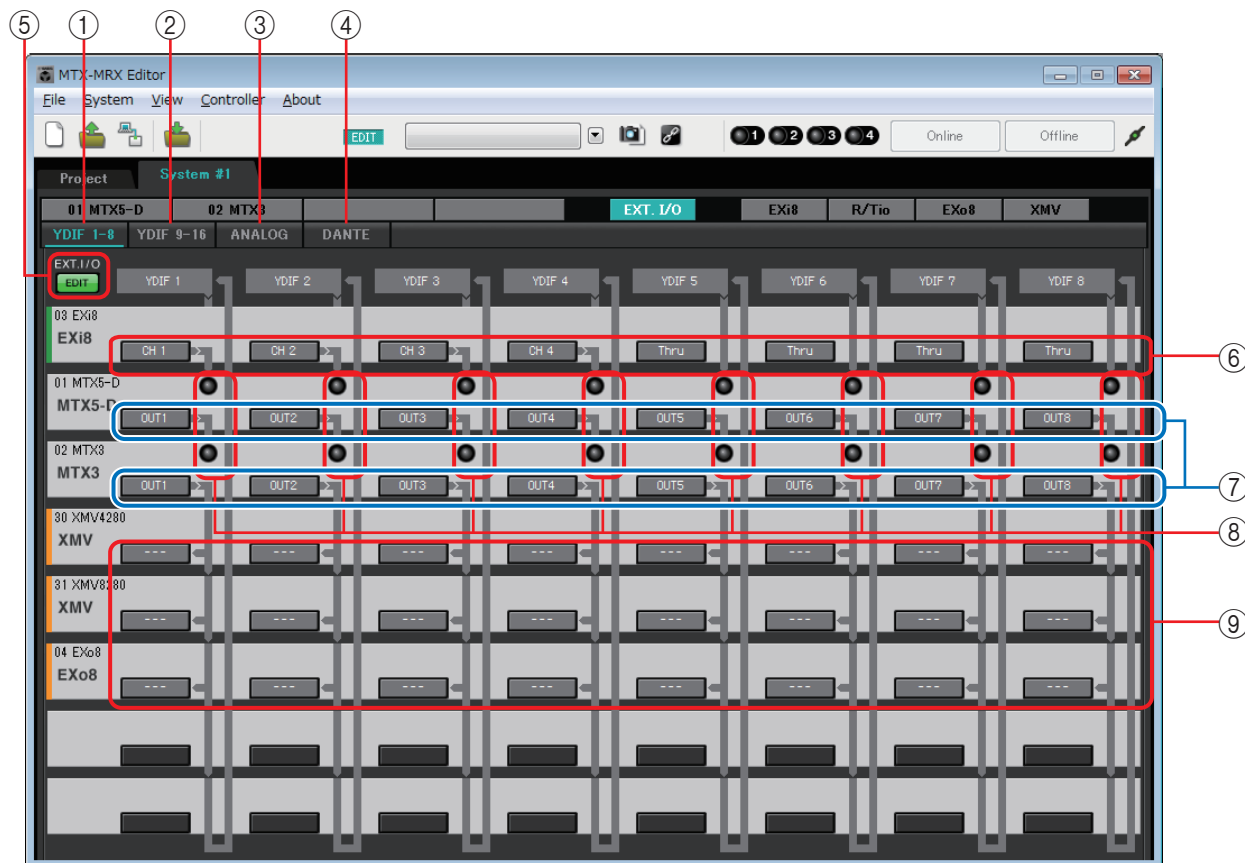

- ① **[YDIF 1-8] button**  
Displays the “YDIF1-8” screen. Here you can specify the routing for YDIF channels 1–8.
- ② **[YDIF 9-16] button**  
Displays the “YDIF9-16” screen.  
Here you can specify the routing for YDIF channels 9–16.
- ③ **[ANALOG] button**  
Displays the “ANALOG” screen.
- ④ **[DANTE] button**  
Displays the “DANTE” screen.
- ⑤ **[EDIT] button**  
Enables the input routing select buttons / output routing select buttons of a device other than an MTX/MRX unit.

**NOTE** The [EDIT] button is available only in Distribution mode when a device other than an MTX/MRX unit is connected via YDIF and the system is offline.

### ⑥ Input routing select buttons

These buttons open the “YDIF In Patch” dialog box, where you can select the input source device and channels for the YDIF signal.

To enable these buttons, click the [EDIT] button.

- NOTE**
- These settings are not included in the preset. For this reason, they can be edited only after clicking the [EDIT] button, in order to prevent the settings from being changed casually.
  - This is available only in Distribution mode when the EXi8 is connected via YDIF and the system is offline.

### ⑦ Selection buttons for output signals from the MTX to YDIF

These buttons open the “Channel Select” dialog box where you can select which signals of the MTX will be output to YDIF channels. These settings are included in the preset.

### ⑧ YDIF IN input indicators

These indicators show YDIF input signals for the MTX/MRX unit.

### ⑨ Output routing select buttons

These buttons open the “YDIF Out Patch” dialog box where you can select the device and channels to which the YDIF signal will be output.

To enable these buttons, click the [EDIT] button.

- NOTE**
- These settings are not included in the preset. For this reason, they can be edited only after clicking the [EDIT] button, in order to prevent the settings from being changed casually.
  - This is available only in Distribution mode when the XMV is connected via YDIF and the system is offline.

# How the settings in each dialog box relate to the "YDIF" screen

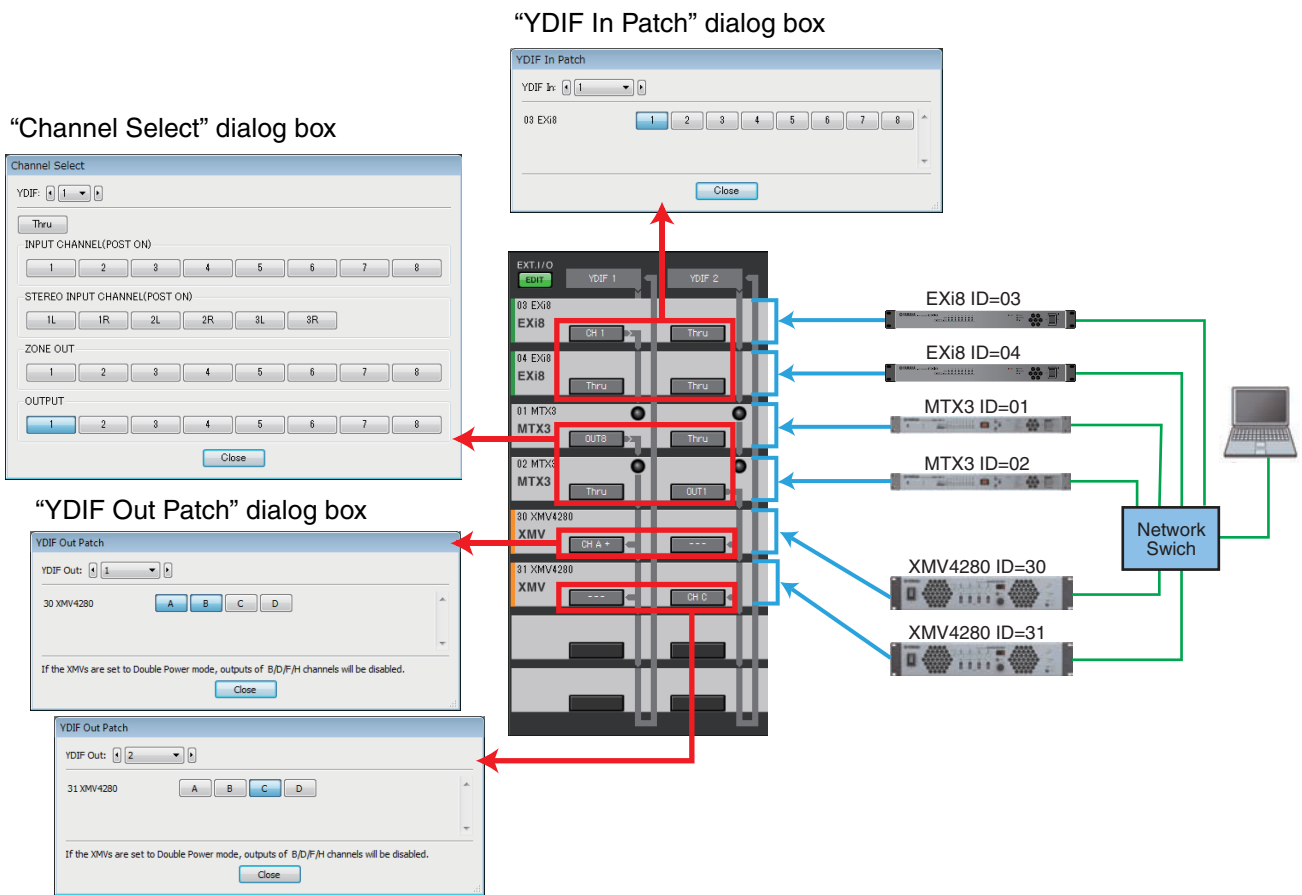

YDIF signal flow with the settings shown above

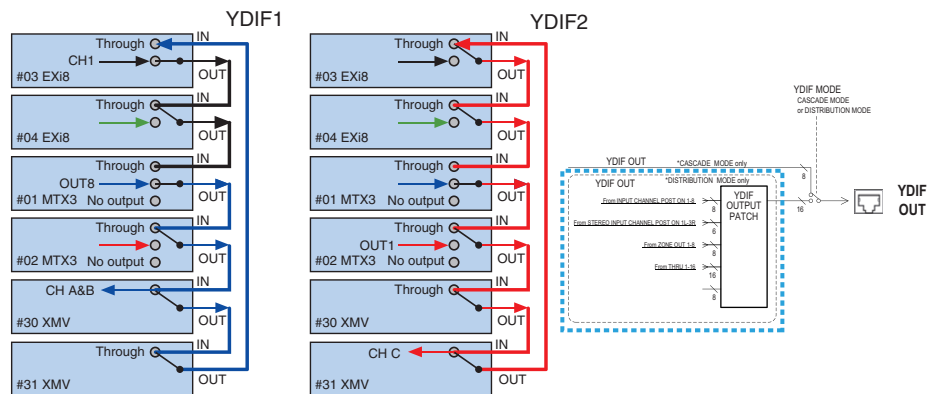

## About YDIF

When connected via YDIF, the XMV will send the audio signals without change to the EXi8/EXo8 or the MTX/MRX. The audio signal will loop unless the EXi8/MTX/MRX unit outputs a different signal or the output is stopped.

## □ “YDIF In Patch” dialog box

Here you can select the input channel for the YDIF signal.

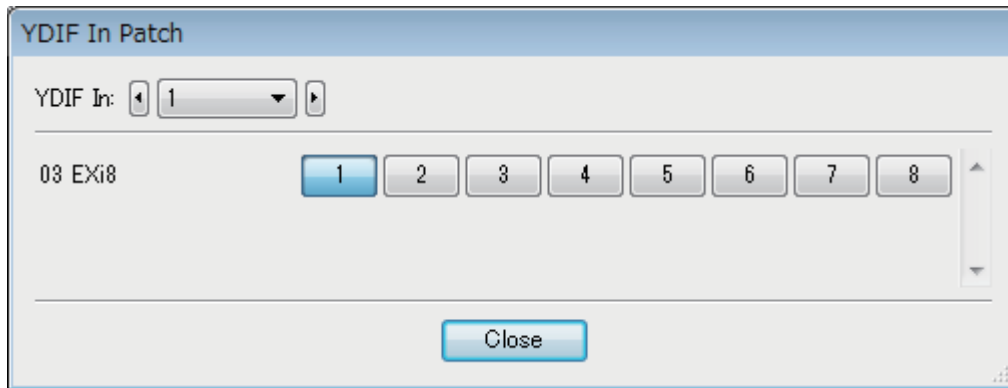

- **[YDIF In:] box**  
Select the YDIF channel that you want to edit.
- **Channel select buttons**  
These buttons select the input channel. The device ID and model name of the input source are shown at the left.
- **[Close] button**  
Closes the “YDIF In Patch” dialog box.

## □ “YDIF Out Patch” dialog box

Here you can select the channels to which the YDIF signal will be output. You can select multiple output destinations.

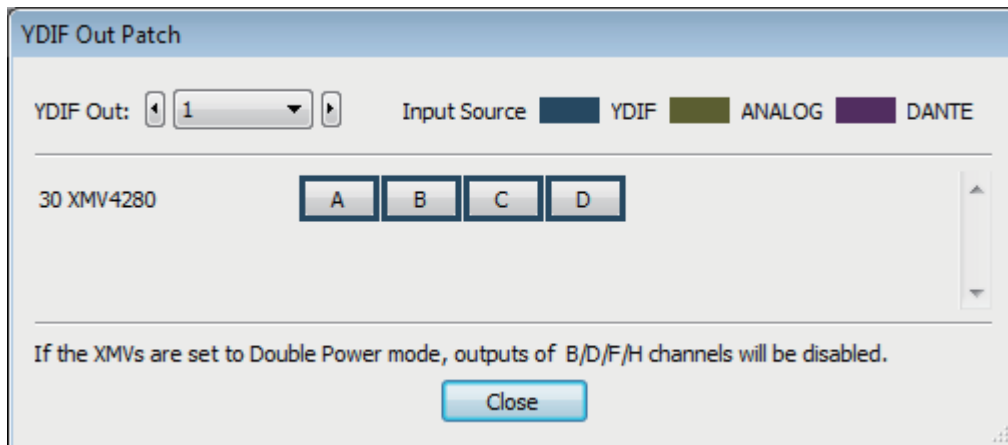

- **[YDIF Out:] box**  
Select the YDIF channel that you want to edit.
- **Channel select buttons**  
These buttons select the output channel. The device ID and model name of the output destination are shown at the left.  
The color of the button’s edge changes to match what is specified for INPUT SOURCE in the [Device] tab of the “Project” screen.
- **[Close] button**  
Closes the “YDIF Out Patch” dialog box.

## □ “Channel Select” dialog box

Here you can select the signals that are output from the MTX to YDIF.

If nothing is selected, the signal will not be output to YDIF.

For the MRX, the connection lines in the “MRX Designer” window determine the destination.

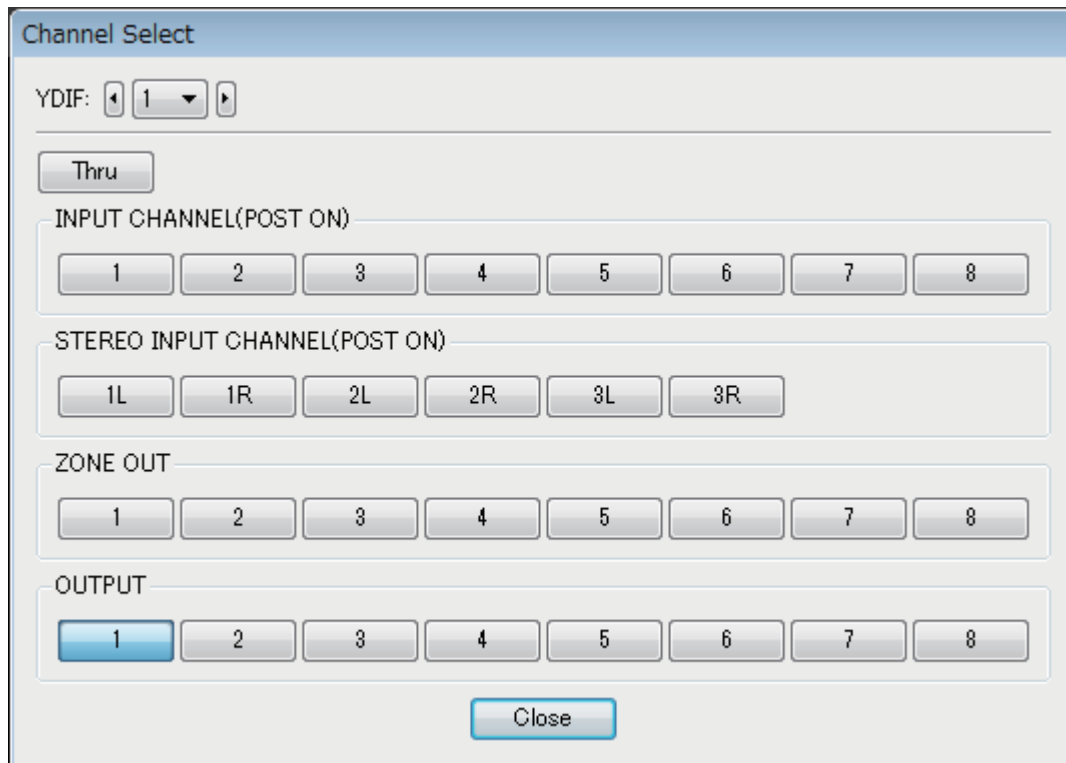

- **[YDIF:] box**  
Select the YDIF channel that you want to edit.
- **[Thru] button**  
The signals coming into YDIF input will be sent to the same YDIF channel without change.
- **INPUT CHANNEL (POST ON)**  
The input channel’s POST signal (after MUTE switching) will be sent to the YDIF channel.
- **STEREO INPUT CHANNEL (POST ON)**  
The stereo input channel’s POST signal (after MUTE switching) will be sent to the YDIF channel.
- **ZONE OUT**  
The signal of the zone output will be sent to the YDIF channel.
- **OUTPUT CHANNEL**  
The signal of the output channel will be sent to the YDIF channel.
- **[Close] button**  
Closes the “Channel Select” dialog box.

## □ “YDIF” screen (Cascade mode)

This screen appears in Cascade mode. It indicates which MTX MATRIX bus is routed to which YDIF output.

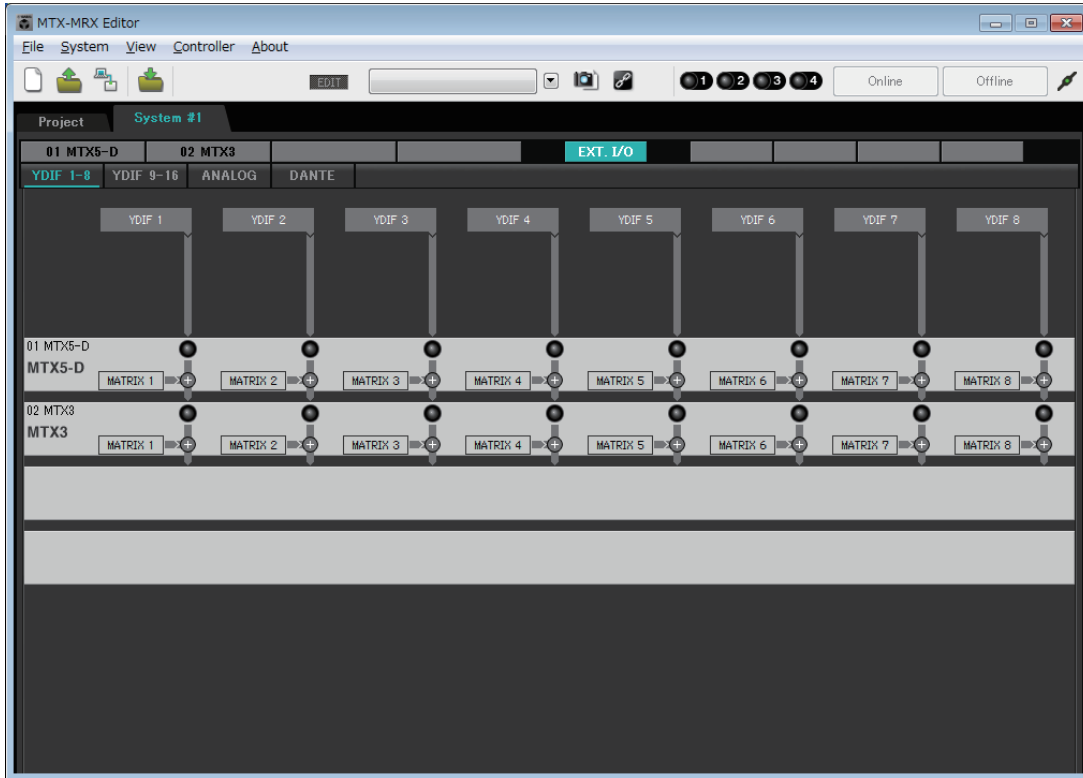

You can turn the YDIF outputs on or off in the [CASCADE MODE] section on the [OUTPUT] tab of the “[MTX Configuration](#)” dialog box.

## □ “ANALOG” screen

Here you can select the XMV unit and the channels of the unit that will input analog audio signals. These settings let you control the parameters of analog-connected XMV units from the [Parameter editing screen](#). However, audio routing settings cannot be made.



① **MTX/MRX select buttons**

Use these buttons to select the MTX/MRX unit that you want to edit.

② **Output routing select buttons**



These open the “[Line Out Patch](#)” dialog box where you can select the output routing.

## □ “Line Out Patch” dialog box

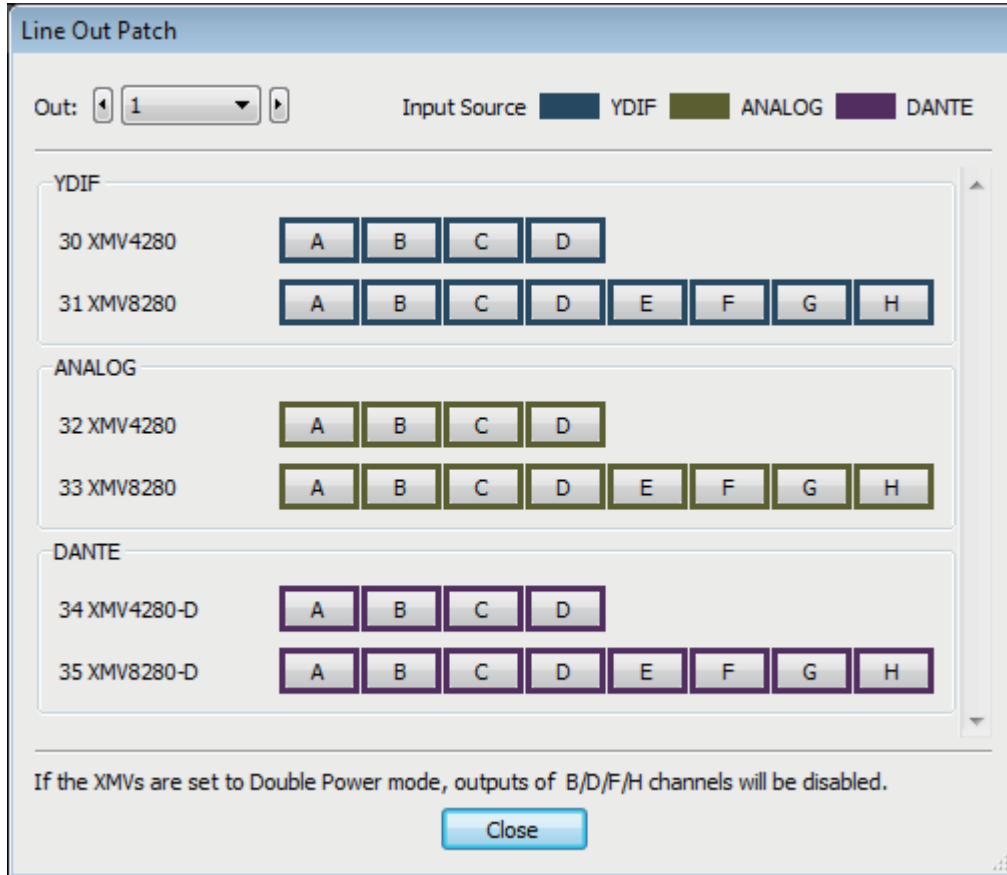
Here you can specify the output destination device and channel for analog signal output from the MTX/MRX unit. You can select multiple output destinations.



- **[Out:] box**  
Select the output channel that you want to edit.
- **Channel select buttons**  
These buttons select the output destination device and channel. The device ID and model name of the output destination are shown at the left.  
The color of the button’s edge changes to match what is specified for INPUT SOURCE in the [Device] tab of the “Project” screen.

INPUT SOURCE	Button edge color	
YDIF	Dark blue	
Analog	Ocher	
DANTE	Purple	

- **[Close] button**  
Closes the “Line Out Patch” dialog box.

## □ "DANTE" screen

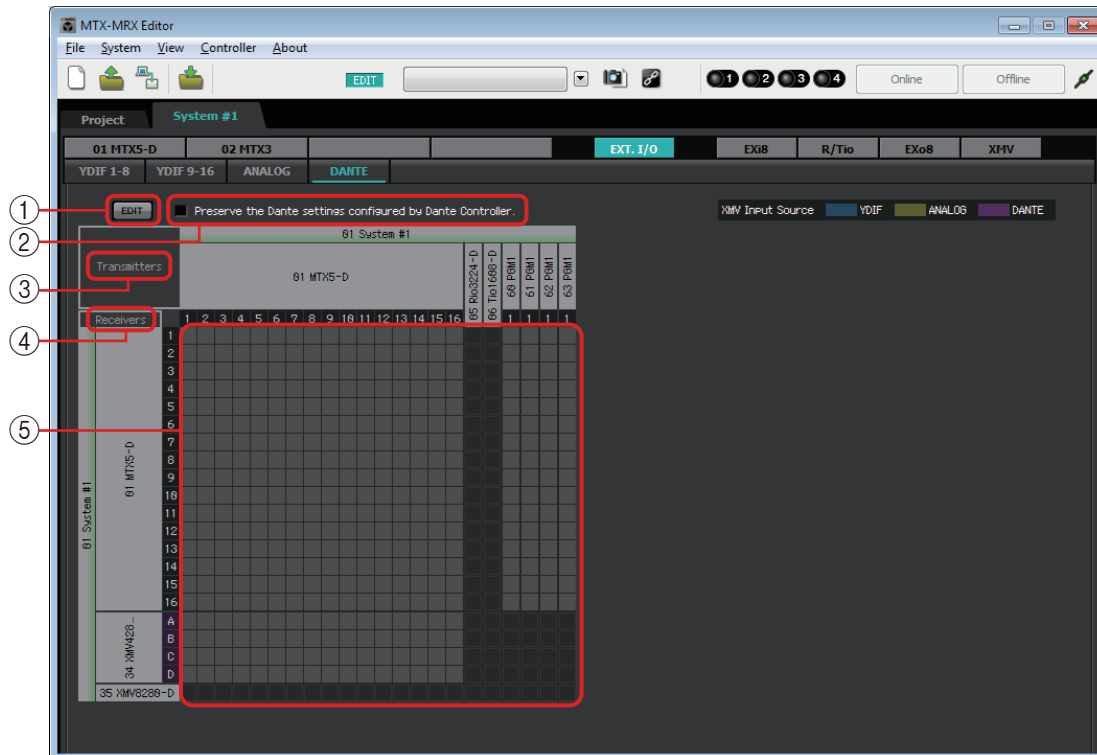

① **[EDIT] button**

Turn this on to enable editing.

② **[Use the settings of Dante Controller] check box**

Select this check box if you're using Audinate Corporation's Dante Controller to set up the Dante network. The settings of Dante Controller will take priority over the settings made in MTX-MRX Editor. If this check box is cleared, you'll be able to use MTX-MRX Editor to make Dante network settings within the project.

③ **[Transmitters]**

This shows the transmitting devices and channels. You can click in the device name column to expand or hide the view. In the case of the MRX, after expanding the view, you can click a range of channels to expand or hide the channel view in 16-channel units. You can drag and drop the device name to change its order.

Move the cursor to a device to view its associations.

④ **[Receivers]**

This shows the receiving devices and channels. You can click in the device name column to expand or shrink the display. In the case of the MRX, after expanding the view, you can click a range of channels to expand or hide the channel view.

The edge color for XMV channels changes to match what is specified for INPUT SOURCE in the [Device] tab of the "Project" screen. For details on the colors, refer to the preceding page.

You can drag and drop the device name to change its order.

Move the cursor to a device to view its associations.

Use Dante Controller to make settings for how the R series (AD/DA) or Tio1608-D receive signals.

**NOTE** Receiving devices can receive signals from up to 24 units.

## ⑤ Matrix

Change the transmission/reception assignments by clicking the location at which an input channel and output channel intersect. The connection is on when the ● symbol is displayed. Devices for which Device Lock is specified by Dante Controller cannot be changed.

If you execute Update Device Information which appears when you right-click, the Device Lock status and the Rio/Tio's Dante Device Name are updated.

**NOTE** *In the matrix you can use the following operations to move the view.*

- Use the cursor keys of the keyboard to move up/down/left/right
- Use the mouse wheel to move up/down
- Hold down <Shift> on the keyboard and use the mouse wheel to move left/right

## ● AES67

The MTX5-D, MRX7-D, and XMV series Dante-enabled models support AES67 starting with V3.20.

Use Dante Controller to set a device to AES67 mode. Use Dante Controller to specify routing for AES67-enabled devices and MTX5-D, MRX7-D, and XMV series Dante-enabled models.

If an MTX5-D, MRX7-D, or XMV series Dante-enabled model is receiving a signal from any AES67-enabled device, the [Transmitters] area indicates "AES67," and the patching information is shown in the matrix.

Although patching with an AES67-enabled device can be deleted in MTX-MRX Editor, it cannot be re-specified.

## ● Device Lock

The MTX5-D, MRX7-D, and XMV series Dante-enabled models support Device Lock starting with V3.2.

Use Dante Controller to lock a device. Locked devices are shown in red.

# “EXi8” screen

Here you can view and edit the parameters of the EXi8 units in the MTX/MRX system. When you right-click on the display area of a desired EXi8, a context menu appears, allowing you to copy and paste settings between devices.

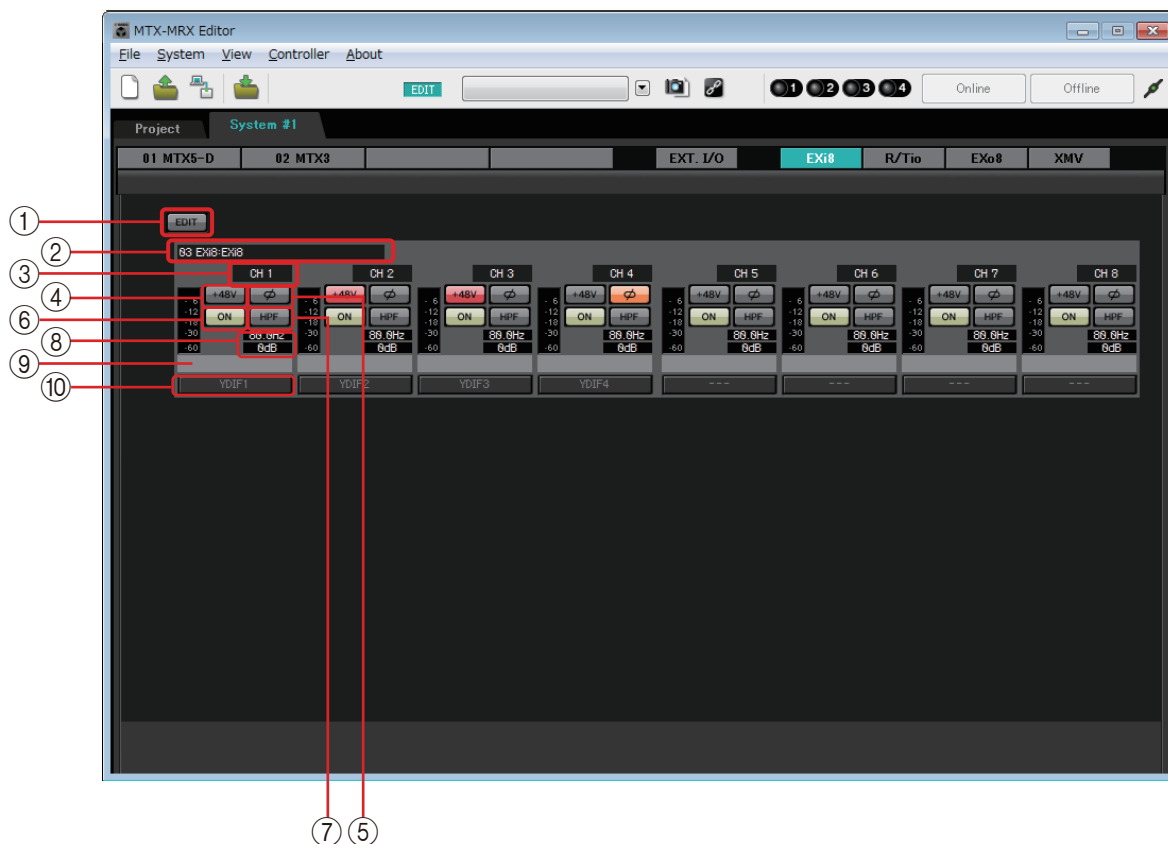

① **[EDIT] button**

This enables the EXi8 output routing select buttons.

**NOTE** The [EDIT] button is available only in the offline state.

② **EXi8 identification area**

Shows the UNIT ID, model type, and model name of the corresponding EXi8 unit.

③ **Channel index**

Indicates the channel number of the EXi8.

④ **[+48V] button**

Turns the HA phantom power (+48V) on/off.

**Notice**

Be sure to leave this button off if you do not need phantom power.

When turning phantom power on, you must observe the precautions below in order to prevent noise and possible damage to the unit and to external devices.

- Leave this button off if a device that does not support phantom power is connected to the [INPUT] connector.
- Do not connect/disconnect a cable to/from the [INPUT] connector while this button is on.
- Lower the output level to the minimum before turning phantom power on/off.

**NOTE** There is no master switch. To avoid malfunctions, be sure to set this appropriately for the equipment that is connected.

- ⑤ **[Ø] button**  
Switches the phase of the input signal.
- ⑥ **[ON] button**  
Switches the input channel on/off.  
The button also shows the on/off status.
- ⑦ **[HPF] button/Cutoff frequency**  
The [HPF] button switches the HPF (High Pass Filter) on/off.  
The cutoff frequency is shown below the [HPF] button.  
You can double-click the cutoff frequency to edit it.
- ⑧ **HA analog gain**  
Shows the HA analog gain setting.  
You can double-click this and edit it.
- ⑨ **Channel name**  
Indicates the channel name.  
You can double-click this and edit it.
- ⑩ **Output routing select button**  
This button opens the “EXi8 Patch” dialog box, where you can select the output destination channels for the audio signal.  
To enable this button, click the [EDIT] button.

## □ “EXi8 Patch” dialog box

Here you can select the output destination channels for the audio signals of the EXi8 unit.

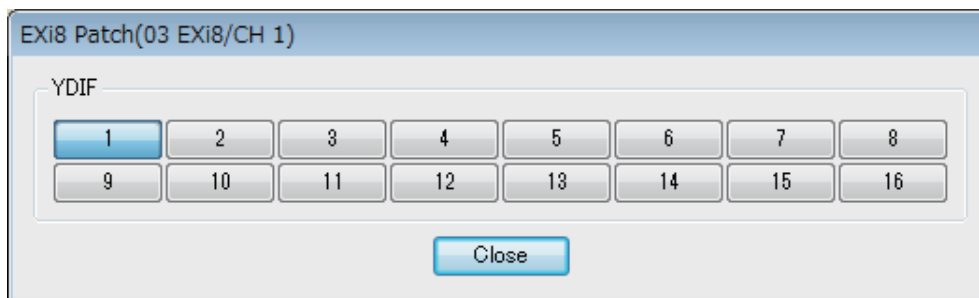

- ① **[YDIF] buttons**  
Select the output destination channels.
- ② **[Close] button**  
Closes the “EXi8 Patch” dialog box.

# “R/Tio” screen

Here you can view and edit the parameters for the analog input jacks of an R series (AD/DA) or Tio1608-D unit. When you right-click on the display area of a desired R series (AD/DA) or Tio1608-D, a context menu appears, allowing you to copy and paste settings between devices.

**NOTE** Since the Ro8-D has no analog input jacks, it is not shown.

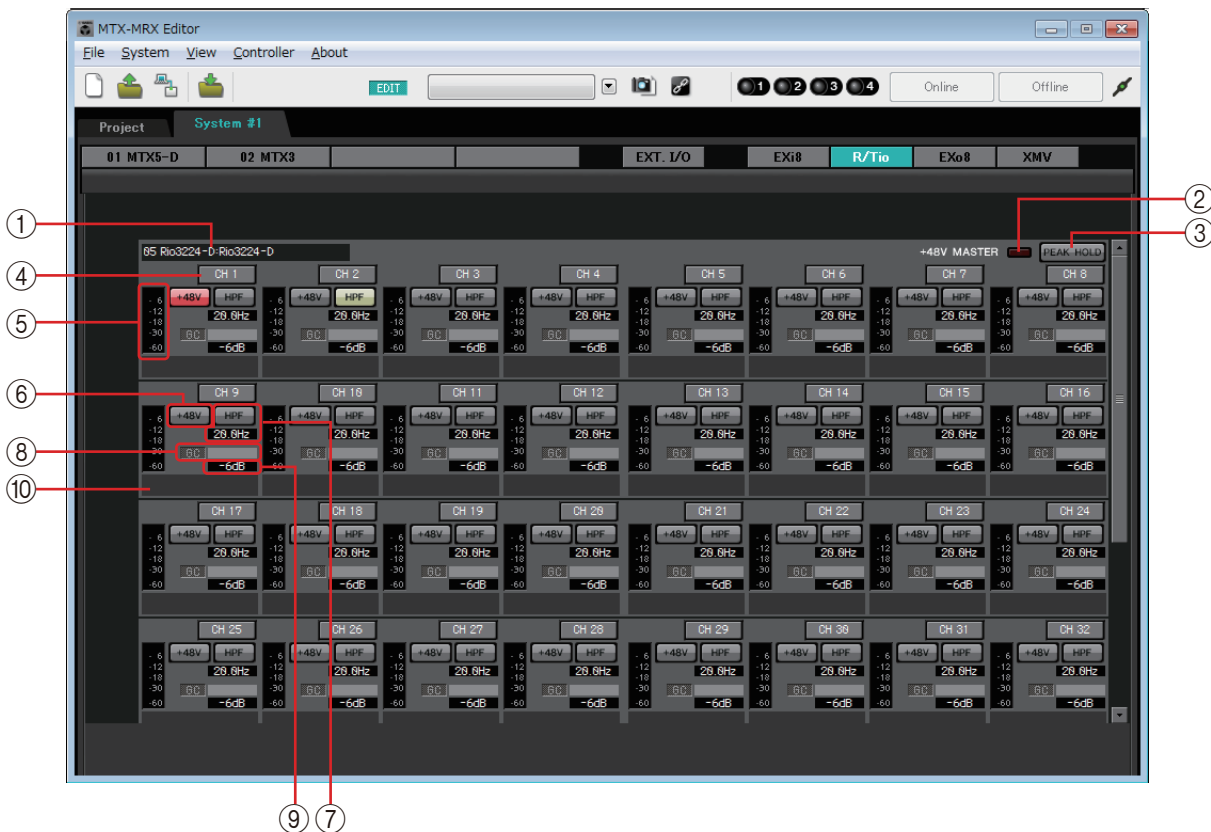

- ① **Device identification field**  
Shows the DEVICE NAME that is specified in the [Device] tab of the “Project” screen.
- ② **“+48V MASTER” indicator**  
Indicates the on/off status of the device’s master phantom power.
- ③ **[PEAK HOLD] button**  
If this button is on, the peaks of each level meter are held. When this button is turned off, the held peaks are cleared.
- ④ **Channel button**  
Indicates the [INPUT] jack number of the device. When you click this, the indicator of the corresponding jack will flash for approximately five seconds, allowing you to identify the jack.
- ⑤ **Level meter**  
Shows the input signal level.
- ⑥ **[+48V] button**  
Turns the HA phantom power (+48V) on/off. This is valid if the unit’s master phantom power is on.

**⑦ [HPF] button / Cutoff frequency**

The [HPF] button switches the HPF (High Pass Filter) on/off.

The cutoff frequency is shown below the [HPF] button. You can double-click the cutoff frequency to edit it.

**⑧ "GC" indicator / gain value**

Indicates the on/off status of the R series (AD/DA) unit's gain compensation. If gain compensation is on, the gain value fixed by gain compensation is shown.

**⑨ HA analog gain**

Shows the HA analog gain setting. You can double-click this and edit it.

**⑩ Channel name**

Indicates the channel name. You can double-click this and edit it.

# “EXo8” screen

Here you can view and edit the parameters of the EXo8 units in the MTX/MRX system. When you right-click on the display area of a desired EXo8, a context menu appears, allowing you to copy and paste settings between devices.

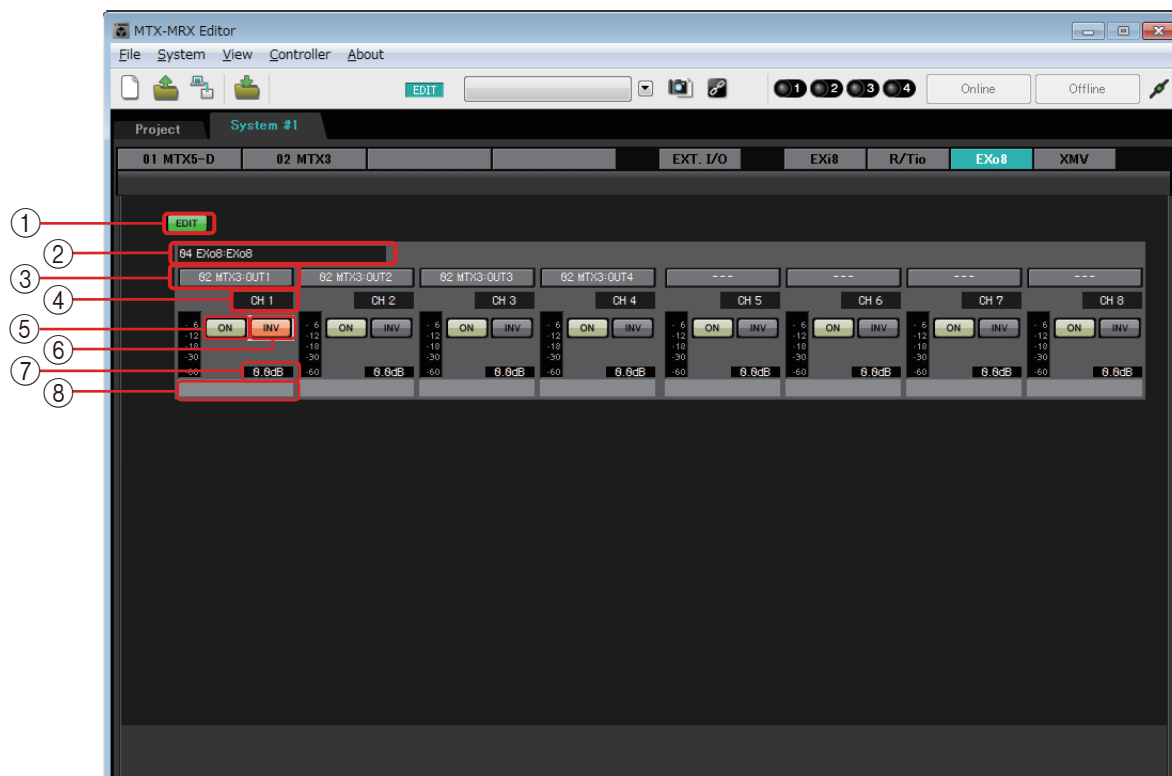

① **[EDIT] button**

This enables the EXo8 input routing select buttons.

**NOTE** The [EDIT] button is available only in the offline state.

② **EXo8 identification area**

Shows the UNIT ID, model type, and model name of the corresponding EXo8 unit.

③ **Input routing select buttons**

These buttons open the “EXo8 Patch” dialog box where you can select the audio signal output source device and channels.

To enable these buttons, click the [EDIT] button.

④ **Channel index**

Indicates the channel number of the EXo8.

⑤ **[ON] button**

Switches the output channel on/off. The button also shows the on/off status.

⑥ **POLARITY button**

Switches the polarity of the output signal.

⑦ **Attenuator**

Shows the EXo output attenuator setting.

You can double-click this and edit it.

⑧ **Channel name**

Indicates the channel name. You can double-click this and edit it.

## □ "EXo8 Patch" dialog box

Here you can select the output source channels for the audio signals of the EXo8 unit.

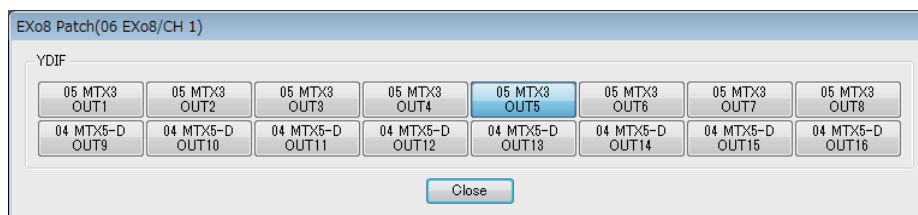

- **[YDIF] buttons**  
Select the output source channel.
- **[Close] button**  
Closes the "EXo8 Patch" dialog box.

# “XMV” screen

Here you can view and edit the parameters of the XMV units in the MTX/MRX system. The units are grouped according to how they are connected: YDIF-connected, analog-connected, or Dante-connected. When you right-click on the display area of a desired XMV, a context menu appears, allowing you to copy and paste settings between devices.

**NOTE** If digital connections and analog connections coexist, we recommend that you set the XMV’s input sensitivity to [-20 dBFS] in the [Device] tab of the Project screen. If this is set to [-20 dBFS], the digital connections and analog connections will have the same input sensitivity.

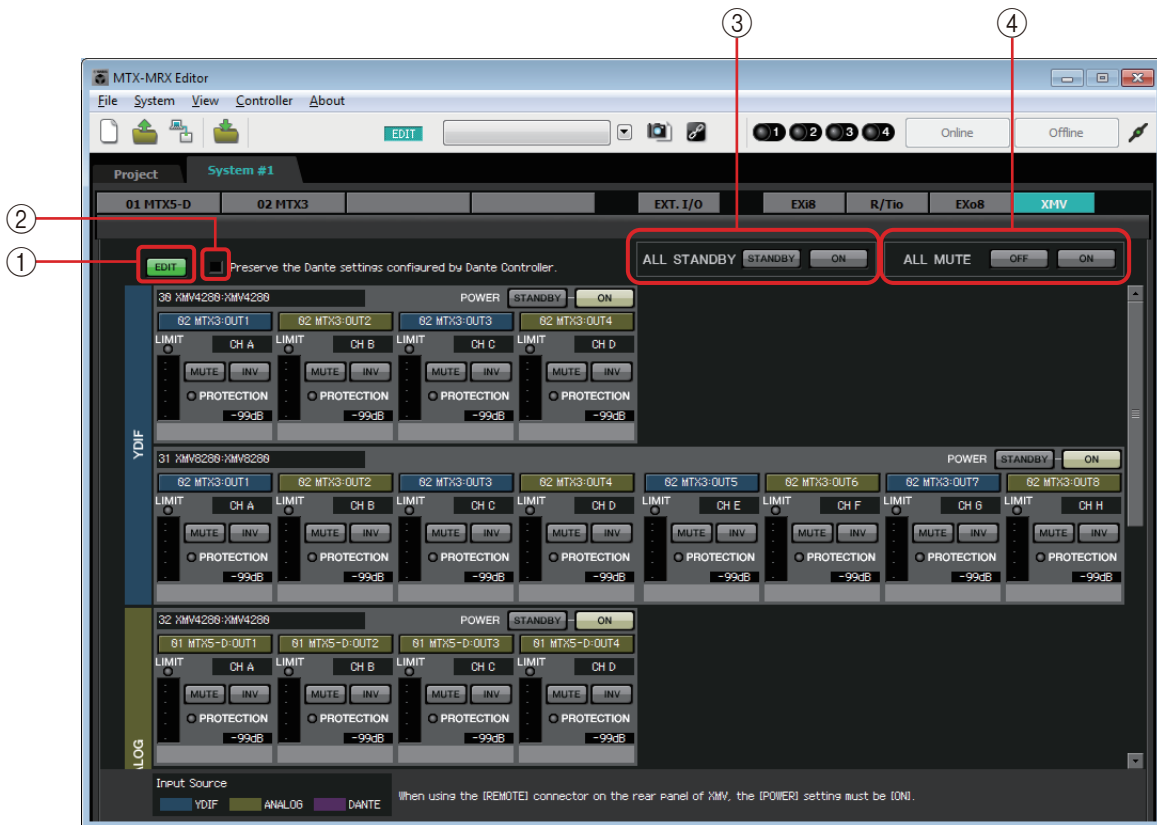

**① [EDIT] button**

This button enables the input routing select buttons for YDIF-connected and Dante-connected XMV units.

**NOTE** The [EDIT] button is available only in the offline state.

**② [Preserve the Dante settings configured by Dante Controller] check box**

Select this check box if you’re using Audinate Corporation’s Dante Controller to set up the Dante network. The settings of Dante Controller will take priority over the settings made in MTX-MRX Editor.

**③ [ALL STANDBY]**

If you click the [STANDBY] button, the power of all XMV units in the MTX/MRX system will be switched to standby. If you click the [ON] button, the power of all XMV units in the MTX/MRX system will be turned on.

**④ [ALL MUTE]**

If you click the [OFF] button, mute will be defeated for all XMV units in the MTX/MRX system. If you click the [ON] button, all XMV units in the MTX/MRX system will be muted.

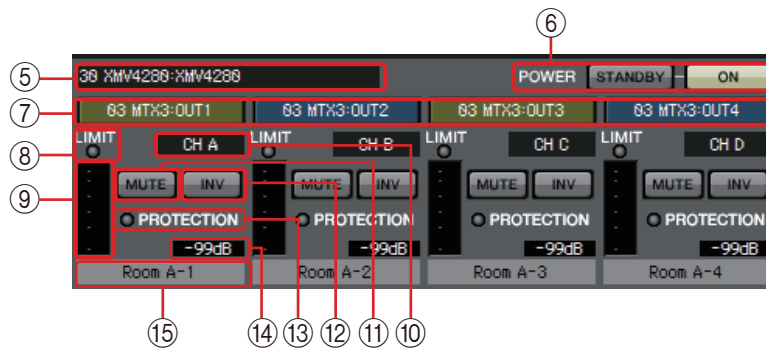

⑤ **XMV identification area**

Shows the UNIT ID, model type, and model name of the corresponding XMV unit.

⑥ **[POWER]**



If you click the [STANDBY] button, the power of the corresponding XMV unit will be switched to standby. If you click the [ON] button, the power of the corresponding XMV unit will be switched on.

⑦ **Input routing select buttons**

These buttons open the “XMV Patch” dialog box where you can select the audio signal output source device and channels.

To enable these buttons for a YDIF-connected or Dante-connected XMV unit, click the [EDIT] button.

The color of the button’s edge changes to match what is specified for INPUT SOURCE in the [Device] tab of the “Project” screen.

INPUT SOURCE	Button edge color	
YDIF	Dark blue	
Analog	Ocher	
DANTE	Purple	

⑧ **[LIMIT] indicator**

This will light if the limiter of the XMV unit itself is operating.

⑨ **Meter**

Shows the output signal level.

⑩ **Channel index**

Indicates the channel number of the XMV.

⑪ **[MUTE] button**

Switches mute on/off for the output channel.

⑫ **POLARITY button**

Switches the polarity of the output signal.

⑬ **[PROTECTION] indicator**

This will light if the protection function of the XMV unit itself is operating.

⑭ **Attenuator**

Shows the XMV’s output attenuator setting.  
You can double-click this and edit it.

⑮ **Channel name**

Indicates the channel name. You can double-click this and edit it.

□ **“XMV Patch” dialog box**

Here you can select the output destination device and channels for the audio signals of the XMV unit. The items shown will depend on the type of connections.

**YDIF**

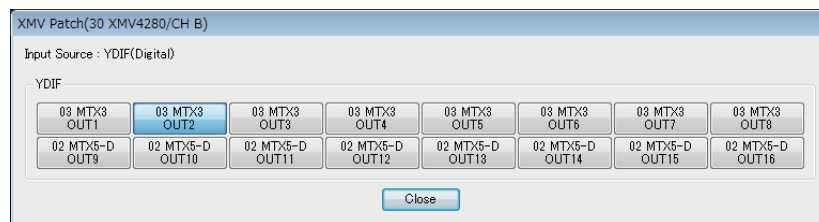

**Analog**

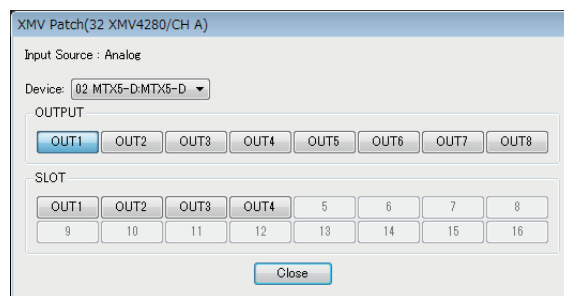

**DANTE**

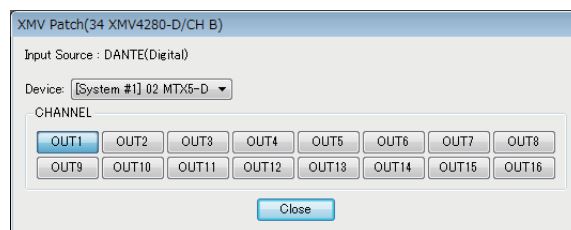

- **Input Source**  
Indicates what is specified as INPUT SOURCE in the [Device] tab of the “Project” screen.
- **[Device:] box (for other than YDIF)**  
Selects the output source device.
- **Channel buttons**  
Select the output source channel.
- **[Close] button**  
Closes the “XMV Patch” dialog box.

# Chapter 5. Online and Synchronization

You can connect the MTX/MRX to your computer and send the settings created using MTX-MRX Editor to the MTX/MRX, or synchronize the MTX/MRX with MTX-MRX Editor and edit the settings. You can also load data from the MTX/MRX into MTX-MRX Editor.

The state in which the MTX/MRX and MTX-MRX Editor operate in synchronization is called the “online state.” The action of bringing them into this state is called “Synchronization.”

Synchronization will match the settings of MTX-MRX Editor and the MTX/MRX itself; when the settings of both are in a matching state, they will go online, allowing the MTX/MRX to be controlled in real time.

**NOTE** *If emergency mode occurs, the system will go offline. It is not possible to synchronize with an MTX/MRX system that is in emergency mode.*

## Online

To go online with MTX-MRX Editor, you can either click the [Online] tool button to access the “Synchronization” dialog box, or choose the [File] menu command [Go Online – From Devices] to access the “Go Online – From devices” dialog box. For details on when each method is appropriate, refer to [Synchronization](#).

### □ “Synchronization” dialog box

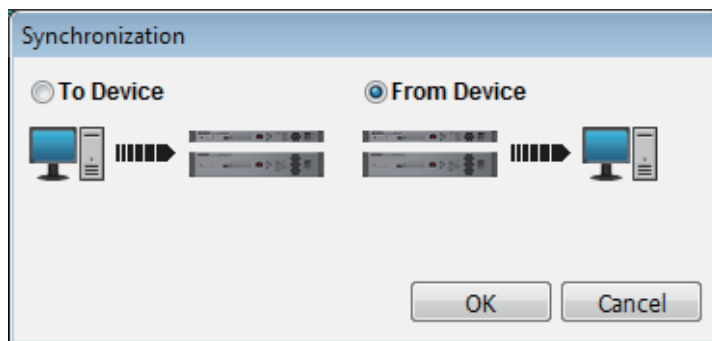

- **[To Device] option button**  
Choose this if you want the settings of MTX-MRX Editor to be applied to the MTX/MRX system.
- **[From Device] option button**  
Choose this if you want the settings of the MTX/MRX system to be applied to MTX-MRX Editor.
- **[OK] button**  
Click this to switch to a display that lets you choose the system that will be synchronized.
- **[Cancel] button**  
Click this to close the dialog box without synchronizing.

## Procedure

### 1. In the toolbar, click the [Online] button.

The “Synchronization” dialog box will appear, allowing you to choose the direction of synchronization.

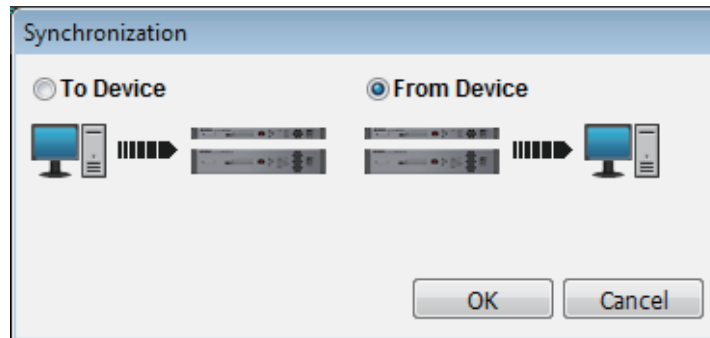

### 2. Choose either [To Device] or [From Device] to specify the direction in which synchronization will occur.

Click the [OK] button to switch to a display that lets you choose the system that will be synchronized. If you click the [Cancel] button, the operation will be cancelled.

#### If you chose [To Device]

The settings of MTX-MRX Editor will be transmitted to the devices, overwriting their settings.

#### If you chose [From Device]

The settings of the devices will be loaded into MTX-MRX Editor.

**NOTE** If the PIN code differs between MTX-MRX Editor's project file and the devices, a PIN code entry dialog box will appear. Enter the correct PIN code to go online.

### 3. Select the MTX/MRX system that you want to place online.

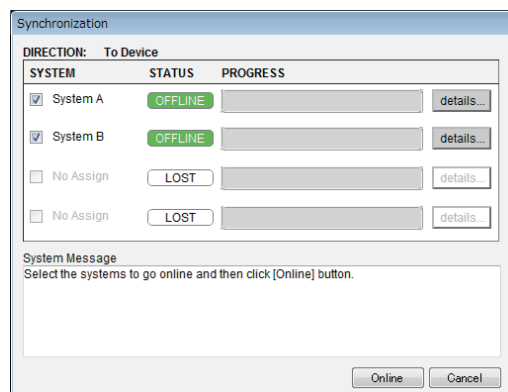

- **[Detail] button**

Displays the progress, synchronization status, and error messages for the devices in each MTX/MRX system.

### 4. Click the [Online] button.

Synchronization will begin. If you click the [Cancel] button, the operation will be cancelled.

**NOTE** If an MRX is assigned to the MTX/MRX system that is being brought online, but compile has not yet been executed, compile is executed automatically. If compile fails or if the memory usage exceeds 100%, the “Compile” dialog box appears, and synchronization is stopped.

## 5. The synchronization progress is displayed.

If you click the [Abort] button, the operation will be halted. This can be a useful way to save time, for example if you've noticed a mistake during synchronization and want to edit a parameter. The settings will have been partially transmitted, so after you've made changes, be sure to complete synchronization to the end.

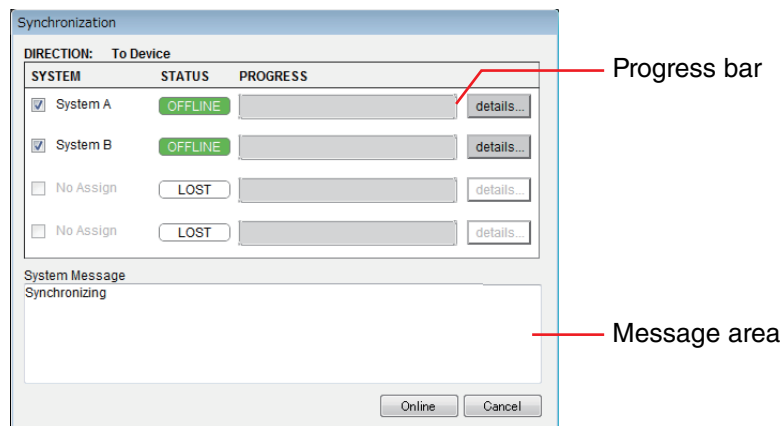

- **Progress bar**  
Shows the status of synchronization.
  - **Message area**  
Details are shown in this area if you click the [Abort] button to stop the process or if an error occurs.
  - **[Abort] button**  
Click this to stop synchronization.
  - **[Online] button**  
When you click this, MTX-MRX Editor will begin synchronizing with the selected MTX/MRX system.
  - **[Close] button**  
Cancels synchronization and closes the dialog box.  
This cannot be clicked during synchronization.
- 6. When synchronization has ended successfully, the progress screen will close automatically.**

## □ “Go online – From devices” dialog box

The settings (configuration and parameters) of the MTX/MRX are loaded into MTX-MRX Editor. In order to execute this, the MTX/MRX whose settings are to be obtained must have been online with MTX-MRX Editor using the To Device setting.

In this dialog box, you can specify how multiple MTX/MRX systems that are found will be assigned to SYSTEM #1 through #4.

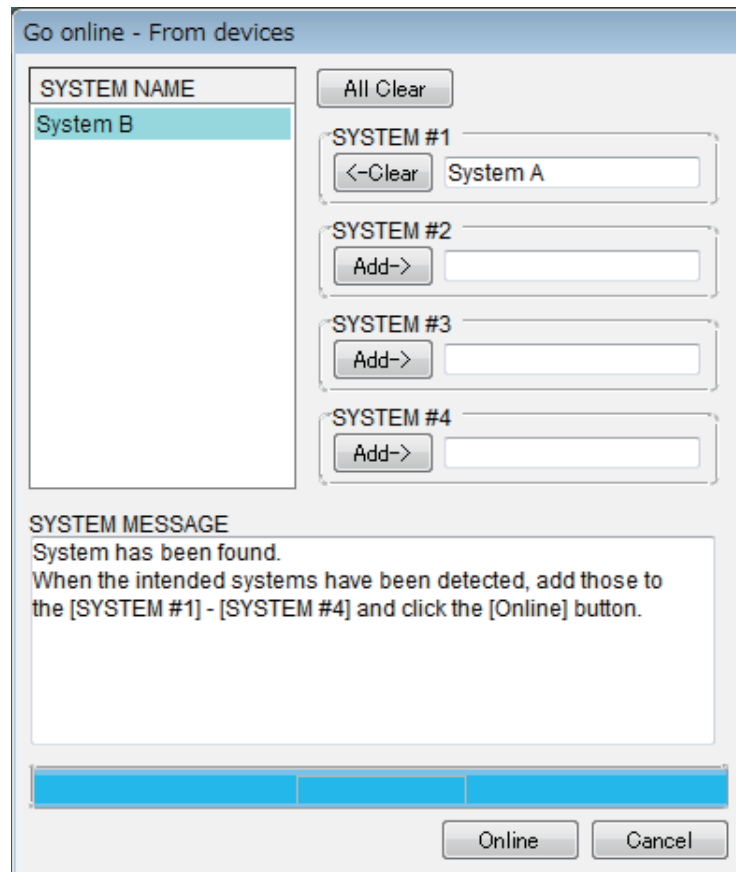

- **[SYSTEM NAME] list**  
The system name will be displayed if you use the [All Clear] button or the [←Clear] button to clear an MTX/MRX system that was found.
- **[All Clear] button**  
Moves all MTX/MRX systems that are assigned as SYSTEM #1 through #4 to the [SYSTEM NAME] list.
- **[←Clear]/[Add→] toggle buttons**  
If you click the [←Clear] button, the specified MTX/MRX system will be moved to the [SYSTEM NAME] list. If you click the [Add→] button, the MTX/MRX system selected in the [SYSTEM NAME] will be assigned.  
The name of the assigned MTX/MRX system is shown at the right of the button.
- **[Online] button**  
When you click this, the settings of the MTX/MRX systems that are assigned as SYSTEM #1 through SYSTEM #4 will start being loaded. When loading is completed, you will be online.
- **[Cancel] button**  
Click this to close the dialog box without synchronizing.

# Synchronization

Synchronization includes the following three operations.

## 1) Synchronizing from the computer (MTX-MRX Editor) to the MTX/MRX unit itself

The settings (configuration and parameters) of MTX-MRX Editor are sent to the MTX/MRX.

Use this method when you have prepared a file beforehand, and want to send those settings to the MTX/MRX on-site.

In the “Synchronization” dialog box, choose [To Device].

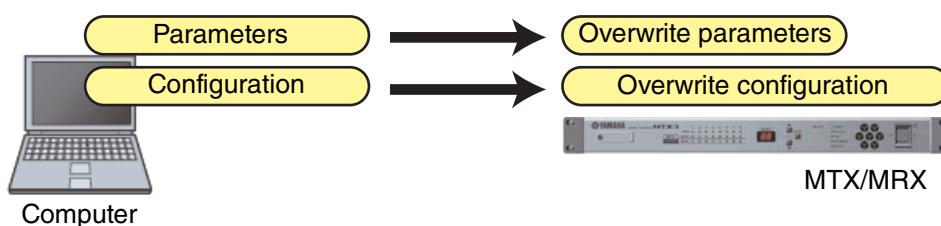
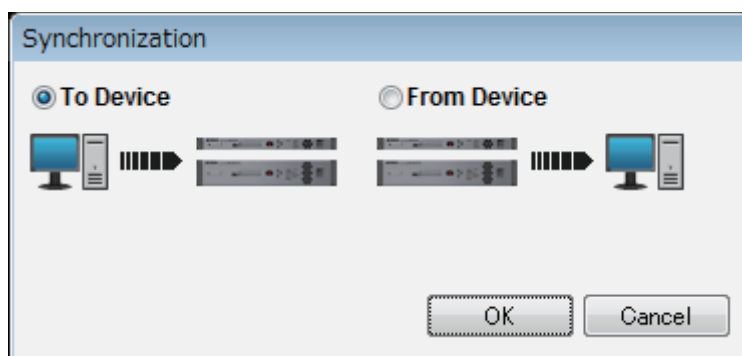

## 2) Synchronizing from the MTX/MRX unit to the computer (MTX-MRX Editor)

### • Case 1

The MTX/MRX's parameters are loaded into MTX-MRX Editor. Use this method when a DCP or Wireless DCP has been used to modify the settings of the MTX/MRX unit, and you want to go back online to modify or view these changes.

Choose [From Device] in the “Synchronization” dialog box.

**NOTE** Synchronization is not possible if there are differences between the MRX unit and MTX-MRX Editor's component type or cabling between components.

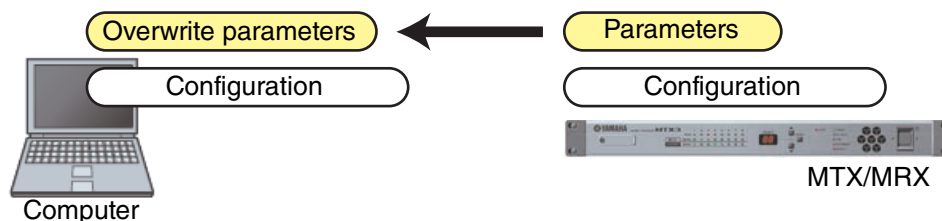
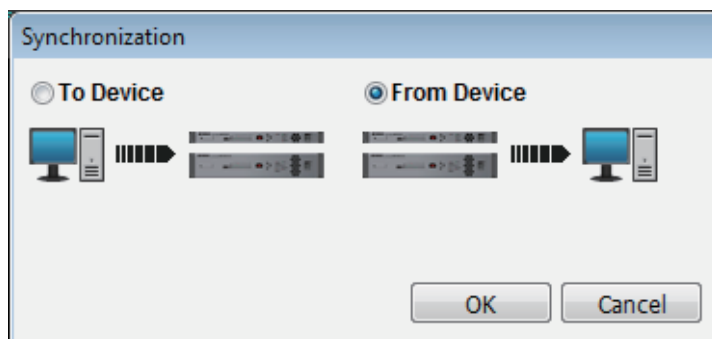

- **Case 2**

The settings (configuration and parameters) of the MTX/MRX are loaded into MTX-MRX Editor. In order to execute this, the MTX/MRX whose settings are to be obtained must have been online with MTX-MRX Editor using the To Device setting. If there is no settings file in MTX-MRX Editor, you can use this method to obtain all of the configuration and parameter data from the MTX/MRX, and use MTX-MRX Editor to edit or check the parameters.

On the [File] menu, click [Go Online – From Devices].

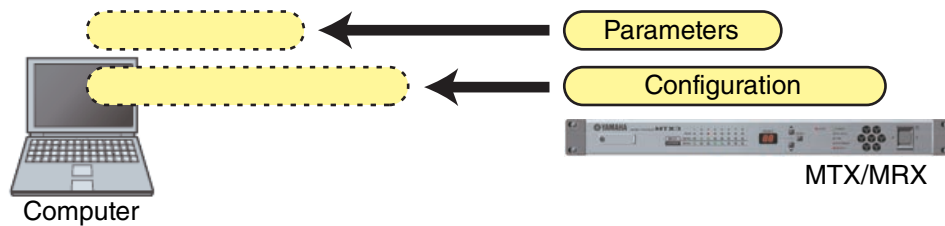
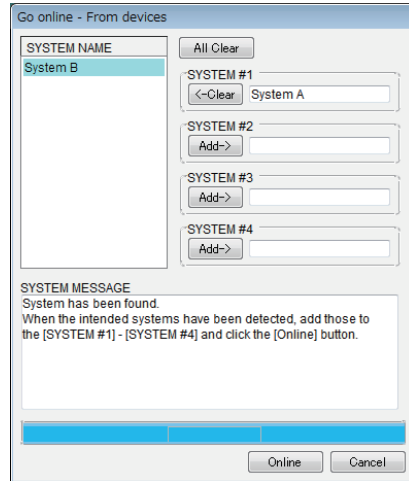

# Chapter 6. Presets

This chapter explains the presets which allow you to change multiple parameters in a single operation. Preset settings are made in the “Preset” dialog box which you can access by clicking the preset button in the toolbar. In this dialog box you can store the settings of multiple parameters as a preset, or recall a stored preset to apply its parameters to the current settings. The parameters of the preset that is applied are called the “current parameters.” You can also copy a stored preset to create a new preset, or delete an unwanted preset.

Presets are made separately for each MTX/MRX system.

**NOTE** If you add devices to the MTX/MRX system, you'll need to store the existing presets once again.

## □ “Preset” dialog box

Here you can make settings for the presets of the selected MTX/MRX system.

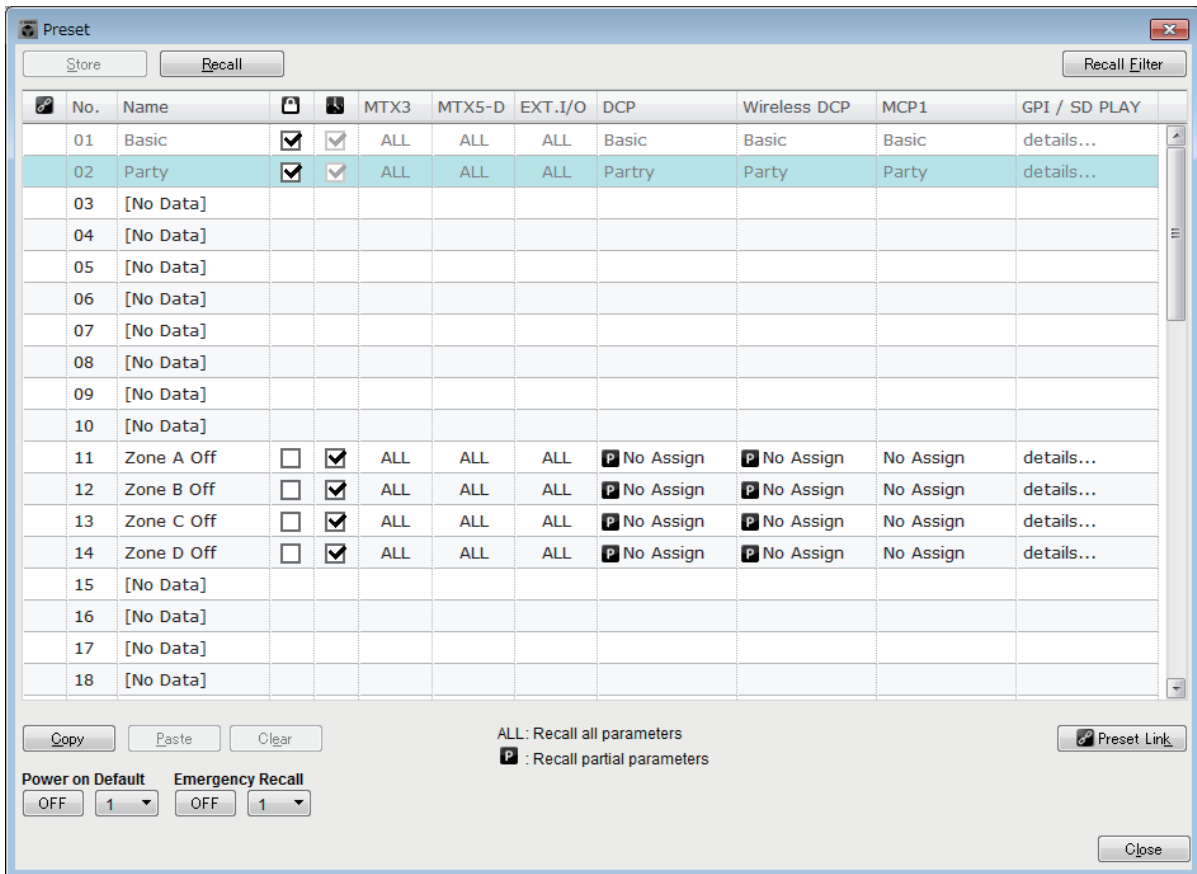

### ● [Store] button

This button stores a preset. The “Store Preset” dialog box will appear.

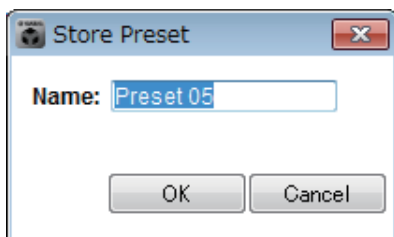

- **[Name:]**  
Input the name of the preset. By default, this will be “Preset + preset number.” You cannot enter a blank preset name.
- **[OK] button**  
This stores the preset and closes the dialog box.
- **[Cancel] button**  
This cancels the preset store operation, and closes the dialog box.

● **[Recall] button**

When you click this button, the currently selected preset will be recalled (loaded) as the current parameters. The number and name of the recalled preset are shown in the [Preset select combo box](#).

● **[Recall Filter] button**

This displays the [Recall Filter setting screen](#).

● **Preset list**

This displays a list of the presets. Up to 50 presets can be stored.

	No.	Name			MTX3	MTX5-D	EXT.I/O	DCP	Wireless DCP	MCP1	GPI / SD PLAY
	01	Basic	<input checked="" type="checkbox"/>	<input checked="" type="checkbox"/>	ALL	ALL	ALL	Basic	Basic	Basic	details...
	02	Party	<input checked="" type="checkbox"/>	<input checked="" type="checkbox"/>	ALL	ALL	ALL	Party	Party	Party	details...
	03	[No Data]									
	04	[No Data]									
	05	[No Data]									
	06	[No Data]									
	07	[No Data]									
	08	[No Data]									
	09	[No Data]									
	10	[No Data]									
	11	Zone A Off	<input type="checkbox"/>	<input checked="" type="checkbox"/>	ALL	ALL	ALL	No Assign	No Assign	No Assign	details...
	12	Zone B Off	<input type="checkbox"/>	<input checked="" type="checkbox"/>	ALL	ALL	ALL	No Assign	No Assign	No Assign	details...
	13	Zone C Off	<input type="checkbox"/>	<input checked="" type="checkbox"/>	ALL	ALL	ALL	No Assign	No Assign	No Assign	details...
	14	Zone D Off	<input type="checkbox"/>	<input checked="" type="checkbox"/>	ALL	ALL	ALL	No Assign	No Assign	No Assign	details...
	15	[No Data]									
	16	[No Data]									
	17	[No Data]									
	18	[No Data]									

- **Preset link ()**  
A check mark is shown for presets whose recall is linked with the presets of another MTX/MRX system.
- **[No.]**  
Shows the preset number (01–50). This cannot be changed.
- **[Name]**  
Shows the preset name. If you select a stored preset and click this area, you’ll be able to edit the name.  
This will indicate [No Data] for empty presets.
- **Protect ()**  
If this check box is selected, the preset will be protected so that it cannot be edited. You can prevent unintended changes by protecting a preset that you don’t want to be overwritten or modified.

- **Scheduler** (  )

If this check box is selected, the scheduler function will be enabled when the preset is recalled.

**NOTE** *If the scheduler is disabled, the [SCHEDULER] indicator of the MTX/MRX unit itself will flash rapidly when the event time occurs.*

- **[MTX3]/[MTX5-D]**

If even one item is specified in the [Recall Filter setting screen](#) as excluded from recall, this area will indicate “  ”.

- **[EXT. I/O]**

If even one item is specified in the [Recall Filter setting screen](#) as excluded from recall, this area will indicate “  ”.

R series (AD/DA) and Tio1608-D are also included in [EXT. I/O].

- **[MRX7-D] (only if there is an MRX assigned in the MTX/MRX system)**

When you execute Store, the screen indicates “ALL Parameters,” and the current parameters of all components are stored.

The MRX7-D has functions that let you recall only specified parameters (snapshots, snapshot groups).

For details about these functions, refer to “MRX Designer User Guide.”

- **[DCP]/[Wireless DCP]/[MCP1]/[GPI/SD PLAY]**

DCP, Wireless DCP, and MCP1 show the library items that will be recalled simultaneously with the preset. For GPI/SD PLAY, this always shows “details...” You can change this setting in the “[Settings](#)” dialog box that appears when you select a stored preset and click this area. However if the preset is protected, the “Settings” dialog box will appear but you won’t be able to make changes.

If no DCP, Wireless DCP, or MCP1 library item is selected, this will indicate “No Assign.” If a “No Assign” preset is recalled, DCP, Wireless DCP, and MCP1 units will be in a state in which parameters have not been assigned. If you want the parameters prior to recall to be maintained, remove them as recall targets in the [Recall Filter setting screen](#).

SD Play will maintain the settings from before the recall occurred.

If library data differs between devices, this is indicated by red characters. Store the corresponding library item once again in the “[Digital Control Panel](#)” dialog box, the “[Wireless DCP](#)” dialog box, or the “[MCP1](#)” dialog box.

**NOTE** *Simply editing the [DCP]/[Wireless DCP]/[MCP1]/[GPI/SD PLAY] settings in the “Settings” dialog box will not apply your changes to the current parameters. In order to apply the settings, you must recall that preset in the appropriate dialog box.*

- **[Copy] button**

This button copies the selected preset.

The Copy command is not available while online.

- **[Paste] button**

This button pastes the copied preset to the preset that’s currently selected in the list.

The Paste command is not available while online.

- **[Clear] button**

This button clears the contents of the preset that’s currently selected in the list.

The Clear command is not available while online.

**● [Preset Link] button**

This displays the “Preset Link” dialog box where you can make settings for linking preset recall between MTX/MRX systems.

**● [Power on Default]**

This specifies the preset that will be recalled when you turn on the power of the MTX/MRX.

If you want the unit to start up with the same settings each time, resetting any changes that were made, turn this on so that the preset you specified will be recalled at start-up. Turn this off if the state at the previous shut-down is important, or if the same operator will be using the system, or if you expect that the power may be turned off during use.

**• [OFF]/[ON] toggle button**

This is an on/off switch for preset recall at startup.

**• Preset select box**

This selects the number of the preset that will be recalled when you turn on the power of the MTX/MRX.

**● [Emergency Recall]**

This specifies the preset that will be recalled when the MTX/MRX receives an EMG (Emergency) signal from an external device or when the input to the +24V [GPI IN] pin (IN 8 for the MTX3, and IN 16 for the MTX5-D and MRX7-D) falls below 2.5V.

**• [OFF]/[ON] toggle button**

Switches recall on/off. Turn this off if +24V is not being applied to the +24V [GPI IN] pin.

**• Preset box**

Selects the preset number that will be recalled.

**● [Close] button**

Closes the “Preset” dialog box.

## "Preset Link" dialog box

Here you can make settings for linking preset recall between MTX/MRX systems. Linking does not occur between MTX/MRX systems that have different subnets.

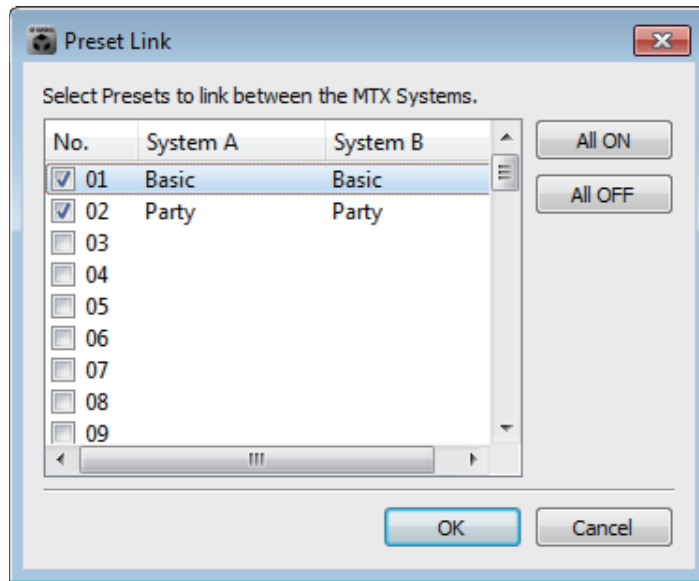

- **Preset list**  
This lists the preset names for each MTX/MRX system in the project. Select the check boxes of presets for which you want preset recall to be linked.
- **[All ON] button**  
Selects the check boxes of all presets.
- **[All OFF] button**  
Clears the check boxes of all presets.
- **[OK] button**  
Specifies the preset recall link settings and closes the dialog box.
- **[Cancel] button**  
Cancels the preset recall link settings and closes the dialog box.

## “Settings” dialog box

Here you can specify the DCP library, Wireless DCP library, MCP1 library, GPI OUT, and SD memory card settings that will be recalled when the preset is recalled.

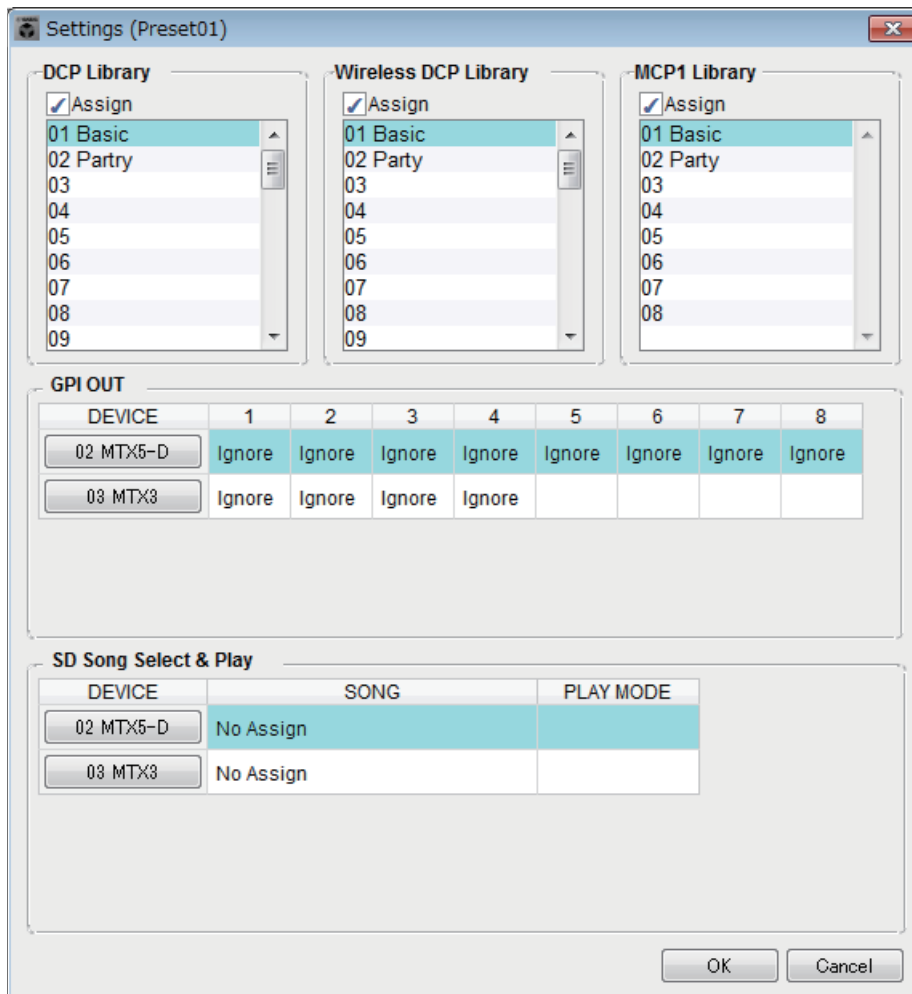

### [DCP Library]/[Wireless DCP Library]/[MCP1 Library]

Here you can specify the library that will be recalled when the preset is recalled. If the [Assign] check box is selected, you’ll be able to select a library item. If the [Assign] check box is cleared, operation from a DCP, Wireless DCP, or MCP1 will not be possible.

If library data differs between devices, this is indicated by red characters. Store the corresponding library item once again in the “[Digital Control Panel](#)” dialog box, the “[Wireless DCP](#)” dialog box, or the “[MCP1](#)” dialog box.

### [GPI OUT]

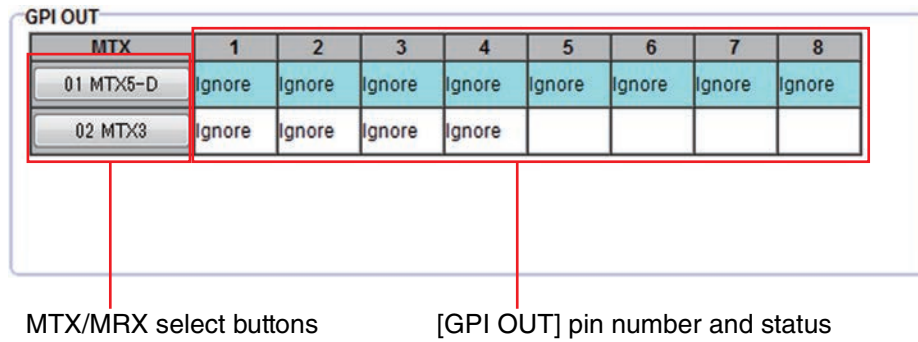

Here you can specify the GPI OUT settings that will be output when the preset is recalled. You can use GPI OUT output to control a device that’s connected to this unit’s [GPI OUT] connectors.

- **MTX/MRX select buttons**  
 Select the button of the MTX/MRX unit whose settings you want to change. (Each button shows the UNIT ID and device name.)  
 This displays the “GPI Out” dialog box.
- **[GPI OUT] pin number and status**  
 This shows the pin numbers of the [GPI OUT] connector, and the status that is specified in the “GPI Out” dialog box.

### [SD Song Select & Play]

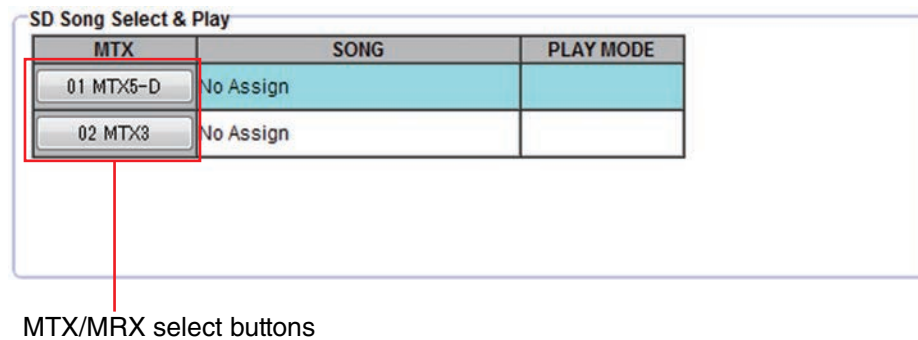

Here you can specify a file that will be played when the preset is recalled. Each MTX/MRX unit can play one file or play all files in the same folder in ascending alphabetical order. If four MTX/MRX units are connected via YDIF, up to four files can be played simultaneously.

If you want multiple songs to play, open the “SD Play” dialog box, click [Folder/File], choose [Play all songs in a folder], and specify the folder that contains the songs. If you frequently need to change the songs that will be played, create an identically-named folder on another SD memory card, and save each set of songs on its own SD memory card. This way, you can play back the other songs simply by exchanging SD memory cards, without having to change settings in MTX-MRX Editor.

- **MTX/MRX select buttons**  
 Select the button of the MTX/MRX unit whose settings you want to change. (Each button shows the UNIT ID and device name.)  
 The “SD Play” dialog box will appear.
- **SONG**  
 This shows the file name or folder name you specified in the “SD Play” dialog box.

- **PLAY MODE**  
The [Play Mode] setting of the “SD Play” dialog box is shown.
- **[OK] button**  
Saves the settings and closes the dialog box.
- **[Cancel] button**  
Closes the dialog box without saving the changes.

■ **“GPI Out” dialog box**

Here you can specify the GPI OUT settings that will be output when the preset is recalled. You can use GPI OUT output to control a device that’s connected to this unit’s [GPI OUT] connector.

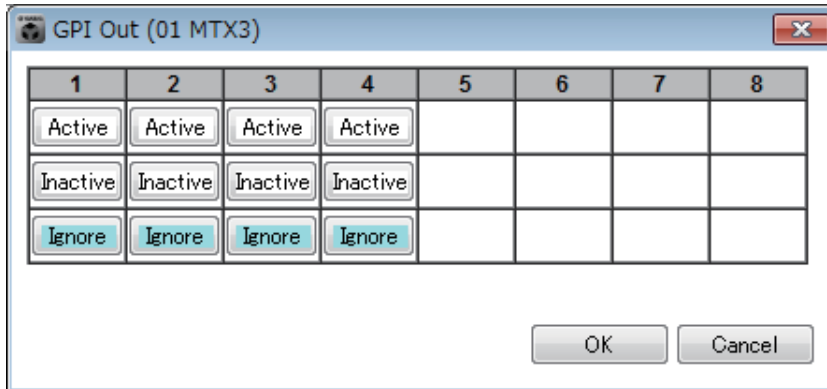

● **[Active]/[Inactive]/[Ignore] buttons**

Specify whether the GPI OUT connector’s output will be enabled (Active), enabled with the OUTPUT TYPE inverted (Inactive), or ignored (Ignore).

If in the “Settings” dialog box accessed by the “System” menu command [GPI], the [OUTPUT TYPE] setting is set to [Pulse] or [Pulse Inv.], the only available choices will be [Active] and [Ignore].

“Settings (Output Port)” dialog box for “GPI”

[OUTPUT TYPE]

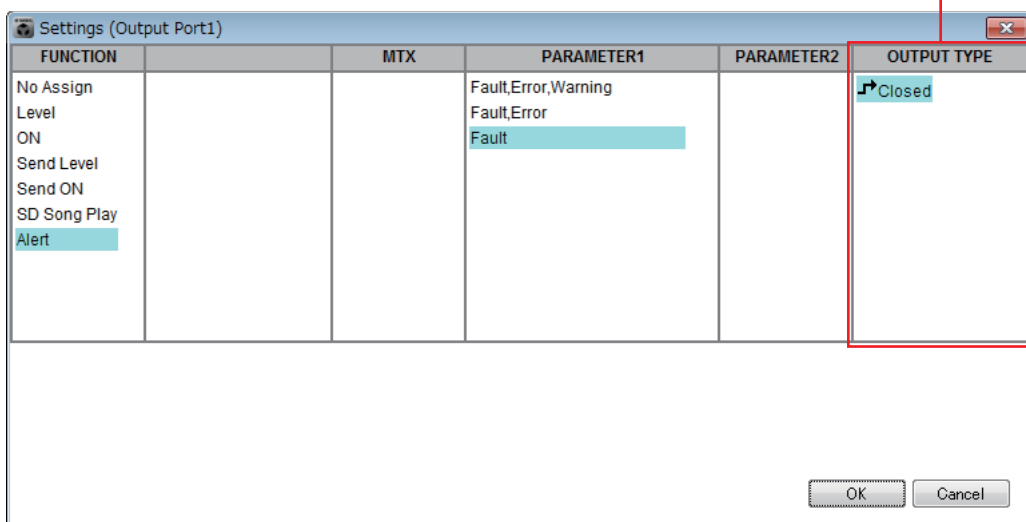

**If [Active] is specified**

When [OUTPUT TYPE] is [Closed], the [GPI OUT] pin will be closed (connected to ground).

When [OUTPUT TYPE] is [Open], the [GPI OUT] pin will be open.

When [OUTPUT TYPE] is [ Pulse], the [GPI OUT] pin will be closed (connected to ground) for approximately 250 ms.

When [OUTPUT TYPE] is [ Pulse Inv.], the [GPI OUT] pin will be open for approximately 250 ms.





**If [Inactive] is specified**

When [OUTPUT TYPE] is [ Closed], the [GPI OUT] pin will be open.

When [OUTPUT TYPE] is [ Open], the [GPI OUT] pin will be closed (connected to ground).

**If [Ignore] is specified**

There will be no change in the output. Use this setting if a different function is assigned to GPI OUT and you don't want that function to be affected by preset recall.

**NOTE** If the GPI “Settings (Output Port)” dialog box [OUTPUT TYPE] is set to [ Closed] or [ Open], and you then specify [Inactive], it will automatically be changed to [Ignore] if you switch to [ Pulse]/[ Pulse Inv.].

- **[OK] button**  
Saves the settings and closes the dialog box.
- **[Cancel] button**  
Closes the dialog box without saving the changes.

**■ “SD Play” dialog box**

Here you can specify a file that will be played when the preset is recalled. Each MTX/MRX unit can play one file or play all files in the same folder. If four MTX/MRX units are connected via YDIF, each MTX/MRX unit can play one file; i.e., a total of up to four files can be played by the system.

If you want multiple songs to play, choose [Play all songs in a folder] in the [Folder/File] area, and specify the folder that contains those songs.

**HINT** If you frequently need to change the files that will be played, create an identically-named folder on another SD memory card, and save each set of songs on its own SD memory card. This way, you can play back the other files simply by exchanging SD memory cards, without having to change settings in MTX-MRX Editor.

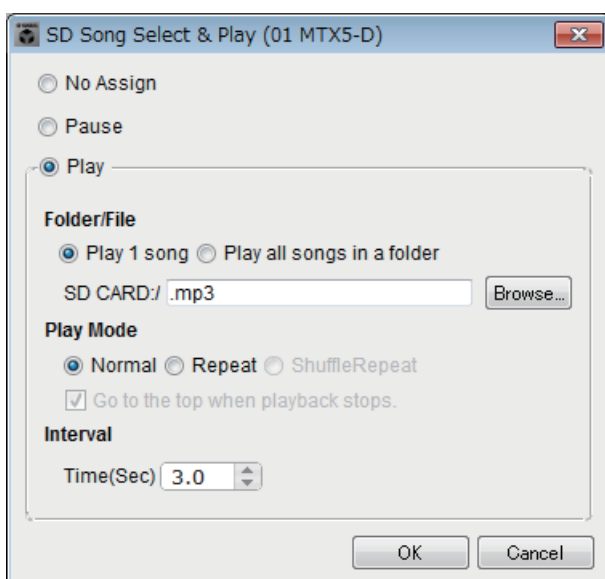

- **[No Assign] option button**  
Choose this if you don't want preset recall operations to change any setting. If a file was being played by the previous preset, playback will continue.

○ **[Pause] option button**

Choose this if you want the currently-playing file to pause.

○ **[Play] option button**

A file will play. Make detailed settings below for the file that will be played.

◆ **Folder/File**

- [Play 1 song]/[Play all songs in a folder]

If you choose [Play 1 song], only the file currently selected in [SD CARD:/] will play.

If you choose [Play all songs in a folder], all files in the folder currently selected in [SD CARD:/] will play.

**NOTE** Up to 100 audio files will be played in ascending order of their file name.

◆ **[SD CARD:/]**

This shows the name of the file or folder that will be played. You can change the name, or enter it directly.

**NOTE** You can also enter Japanese.

**If [Play 1 song] is selected**

Only the file currently selected in [SD CARD:/] will play.

The following file and folder formats can be shown.

- (folder name)\(file name).mp3
- (folder name)\(file name).wav
- (file name).mp3
- (file name).wav

**If [Play all songs in a folder] is selected**

All files saved in the folder currently selected in [SD CARD:/] will play.

The following folder formats can be shown.

- (folder name)
- blank

**NOTE** - Only first-level folders are valid.

- If the folder name is blank, all the files that exist in the root level of the SD memory card will be played (folders below the root level will not be included).

◆ **[Browse] button**

When you click this, a screen will appear, allowing you to select the file or folder to be played.

If [Play 1 song] is selected, choose a file.

If [Play all songs in a folder] is selected, choose a folder.

**NOTE** - Only first-level folders are valid.

- If the folder name is blank, all the files that exist in the root level of the SD memory card will be played (folders below the root level will not be included).

### ○ **Play Mode**

#### ◆ **[Normal]/[Repeat]/[Shuffle Repeat]**

This specifies the play mode for the file or files.

If you choose [Normal], the specified file or files in the folder will play once.

If you choose [Repeat], the specified file or files in the folder will play repeatedly.

If you choose [Shuffle Repeat], the files in the specified folder will play repeatedly in random order. If you choose [Play 1 song] in [Folder/File], the [Shuffle Repeat] setting will be unavailable.

#### ◆ **[Go to the top when playback stops.]**

This is always on; playback will always start from the beginning of the song or the first song in the folder. (This is unchangeable only for preset recall.)

#### • **[Interval Time]**

This specifies the playback spacing when files are played consecutively.

#### • **[OK] button**

Saves the settings and closes the dialog box.

#### • **[Cancel] button**

Closes the dialog box without saving the changes.

### Main usage method

#### **1. Prepare the SD memory card.**

Copy the files that you want to play into the SD memory card. If you want to play multiple files, place them in a folder no deeper than the first level.

#### **2. Insert the SD memory card you prepared in step 1 into the computer.**

#### **3. In [SD Song Select & Play], click the MTX/MRX select button for the unit into which you intend to insert the SD memory card.**

The "SD Play (MTX)" dialog box will appear.

#### **4. Click the [Browse] button, and select a file or folder.**

#### **5. Insert the SD memory card into the MTX/MRX.**

#### **6. Synchronize MTX-MRX Editor with the MTX/MRX (refer to "[Online and Synchronization](#)"), sending the settings of MTX-MRX Editor to the MTX/MRX.**

#### **7. Recall the preset.**

The file or files in the SD memory card inserted in the MTX/MRX unit you selected in step 2 will play.

If you specified a folder, you can replace the files in the folder and the result will be the same.

## Recall Filter setting screen

Here you can specify which parameters will be recalled when you recall a preset. For example if the input/output levels do not change for any of the presets, you can exclude the INPUT LEVEL and OUTPUT LEVEL from recall, so that the level settings can stay the same without your having to re-specify the levels for each preset.

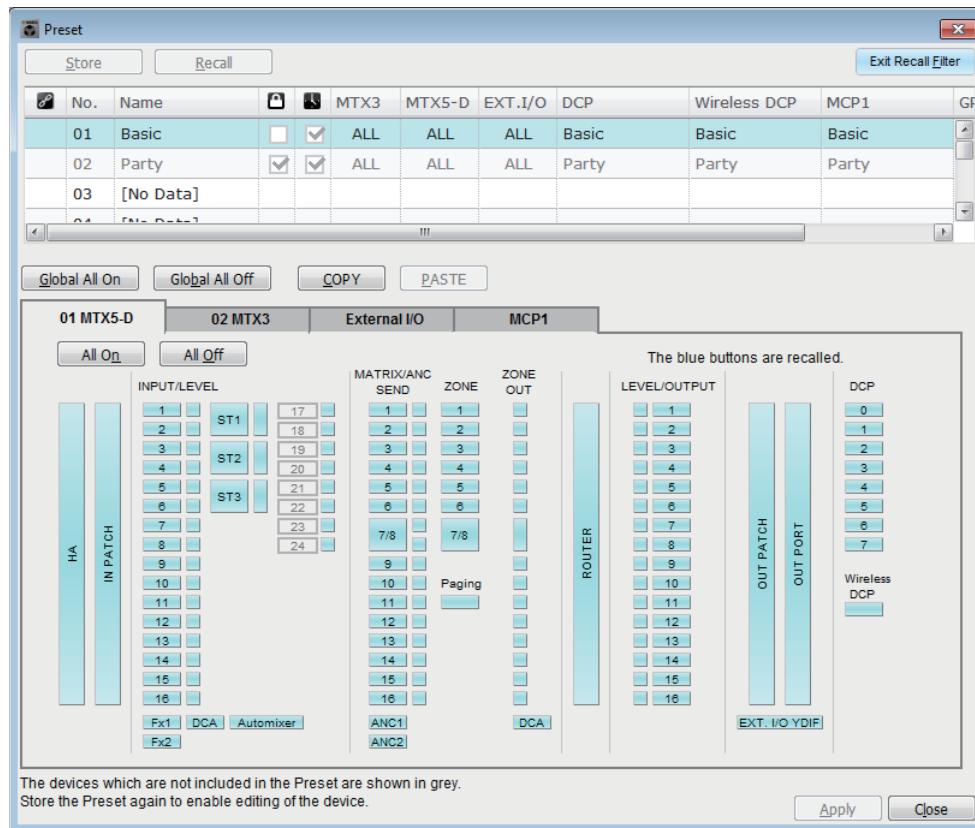

### ■ [Exit Recall Filter] button

Closes the Recall Filter setting screen, and returns to the “Preset” dialog box.

### ■ Preset list

Here you can choose the preset for which to make Recall Filter settings.

- NOTE**
- You cannot select an empty preset.
  - You cannot edit a preset that is protected.

### ■ [Global All On] button

Turns on (blue) all of the buttons in all tabs. All parameters of all devices will be recalled.

### ■ [Global All Off] button

Turns off (white) all of the buttons in all tabs. No parameters of any device will be recalled.

### ■ [COPY] button

Copies the Recall Filter settings of the selected preset.

The Copy command is not available while online.

### ■ [PASTE] button

Pastes the copied Recall Filter settings to the currently selected preset.  
The Paste command is not available while online.

### ■ [Apply] button

Applies the currently-edited Recall Filter settings. If the settings have not been edited, this button will be unavailable and cannot be clicked.

### ■ [Close] button

Closes the dialog box.

### ■ [MTX]/[MRX] tab

Here you can choose the MTX/MRX unit for which to make Recall Filter settings. The tab shows the UNIT ID and device name.

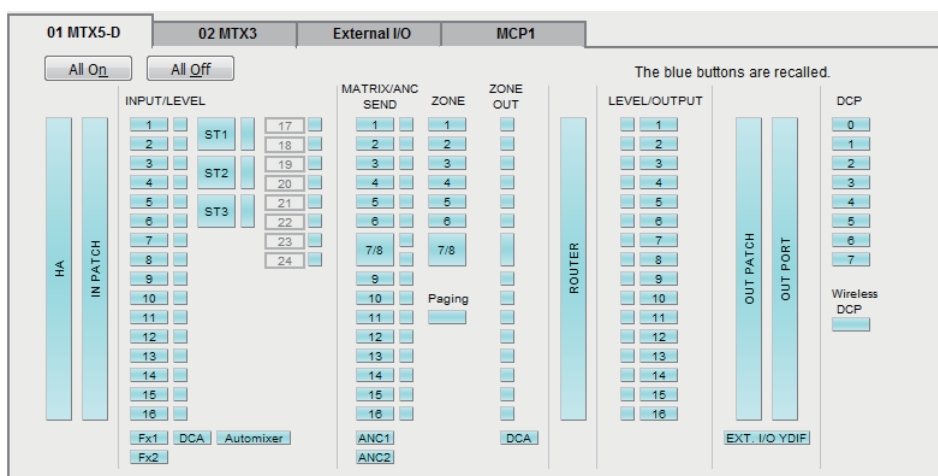

### ● [All On] button

Turns on (blue) all of the buttons of the currently selected tab. All parameters will be recalled.

### ● [All Off] button

Turns off (white) all of the buttons of the currently selected tab. None of the parameters will be recalled.

### ● Parameter select buttons

For the MRX, only the [DCP] button and [Wireless DCP] button are shown.

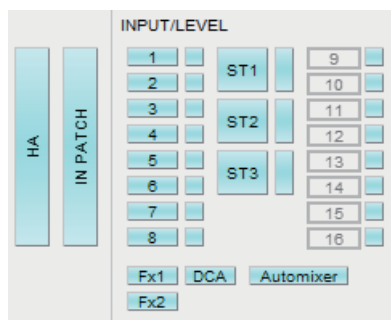

#### • [HA] button

If this is on, the HA gain and phantom power (+48V) settings of the input ports will be recalled.

- **[IN PATCH] button**

If this is on, the input patch settings and input channel names will be recalled.

These buttons include patching to the MY4-AEC input channels From Far-end, Far-end Voice, Near-end Mic., Near-end Voice, and To Far-end.

- **[INPUT]/[LEVEL] buttons**

If the [INPUT] button is on, the following input channel settings will be recalled.

**Input channels:** Phase, HPF, Digital Gain, PEQ, COMP, GATE, AGC, FBS, Insert on/off (\*)

**Stereo input channels:** Digital Gain, PEQ, AGC, COMP

(\*) Insert on/off is only for the MTX5-D.

If the [LEVEL] button is on, the input channel level and on/off (mute) settings will be recalled.

These can be specified individually for each channel.

**NOTE** In the "MTX Configuration" dialog box, if [INPUT PORT SETUP] is changed from "MONO x2" to "STEREO," the settings of the [INPUT]/[LEVEL] buttons will follow the "L" side.

- **[Fx1]/[Fx2] buttons**

If these buttons are on, the effect type and the following settings will be recalled.

- Send level from the input channel to the effect bus, send on/off
- Effect return level, on/off (mute)
- Effect return name

- **[DCA] button (INPUT side)**

If this is on, the following settings will be recalled.

- The input channel's assignment to DCA or mute group
- Master level of the DCA group
- Master mute of the mute group

- **[Automixer] button**

If this is on, the settings of the Dugan Automixer will be recalled.

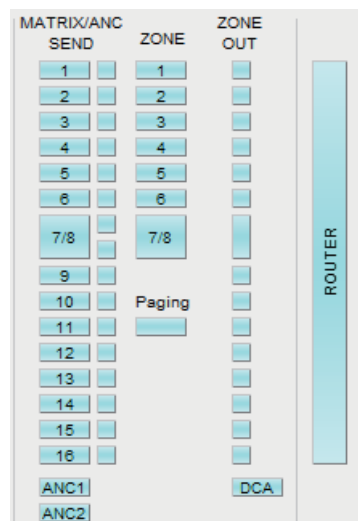

- **[MATRIX SEND] button**

If the button at the left is on, the following settings will be recalled.

- Send level from the input channel to the matrix bus, send on/off, and stereo channel pan
- Send level from effect return to the matrix bus, send on/off, and stereo channel pan

If the button at the right is on, the matrix out level will be recalled.

- **[ANC1 SEND]/[ANC2 SEND] buttons**

If these buttons are on, the send level from the input channel to the ANC bus and the send on/off status will be recalled.

- **[ZONE] button**

If this is on, the following settings will be recalled.

- 1st Priority's Priority Source, Mix Level, and Ducker
- 2nd Priority's Priority Source, Mix Level, and Ducker
- ANC
- Zone name

**NOTE** In the "MTX Configuration" dialog box, if [INPUT PORT SETUP] is changed from "MONO x2" to "STEREO," the setting of the [ZONE] button will follow the odd-numbered zone.

- **[PAGING] button**

Turning this on recalls the setting of the PAGING [ON] button.

- **[ZONE OUT] button**

If this is on, the ZONE Out Level and on/off (mute) will be recalled.

- **[DCA] button (ZONE side)**

If this is on, the following settings will be recalled.

- ZONE Out's channel assignment to DCA or mute group
- Master level of the DCA group
- Master mute of the mute group

- **[ROUTER] button**

If this is on, the router settings will be recalled.

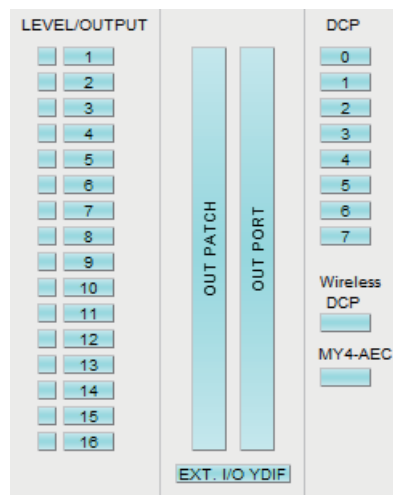

- **[LEVEL]/[OUTPUT] buttons**  
If the [LEVEL] button is on, the output channel level and on/off (mute) settings will be recalled.  
If the [OUTPUT] button is on, the Room EQ, Delay, and Speaker Processor settings will be recalled.  
These can be specified individually for each channel.
- **[OUT PATCH] button**  
If this is on, the output patch settings and output channel names will be recalled.
- **[OUT PORT] button**  
If this is on, the output port's output gain and polarity settings will be recalled.
- **[EXT. I/O YDIF] button**  
If this is on, settings for the audio that is output from the MTX/MRX to YDIF when in Distribution mode will be recalled.
- **[DCP] button**  
If this is on, the parameter assignments of the DCP (digital control panel) unit connected to the MTX/MRX will be recalled. The button shows the ID of the DCP.
- **[Wireless DCP] button**  
If this is on, the settings of the Wireless DCP will be recalled. If eight Wireless DCP units are connected, eight units will be affected by the on/off setting.
- **[MY4-AEC] button**  
If this is on, the settings of the MY4-AEC installed in the MTX5-D will be recalled. This is not shown if the MY4-AEC is not selected in the "Device Configuration Wizard."  
The following settings are outside the recall settings of the [MY4-AEC] button.
  - From Far-end, Far-end Voice, Near-end Mic., Near-end Voice, and To Far-end (included in the [IN PATCH] button range)
  - SRC

## ■ [External I/O] tab

Here you can choose the external device parameters for which to make Recall Filter settings.

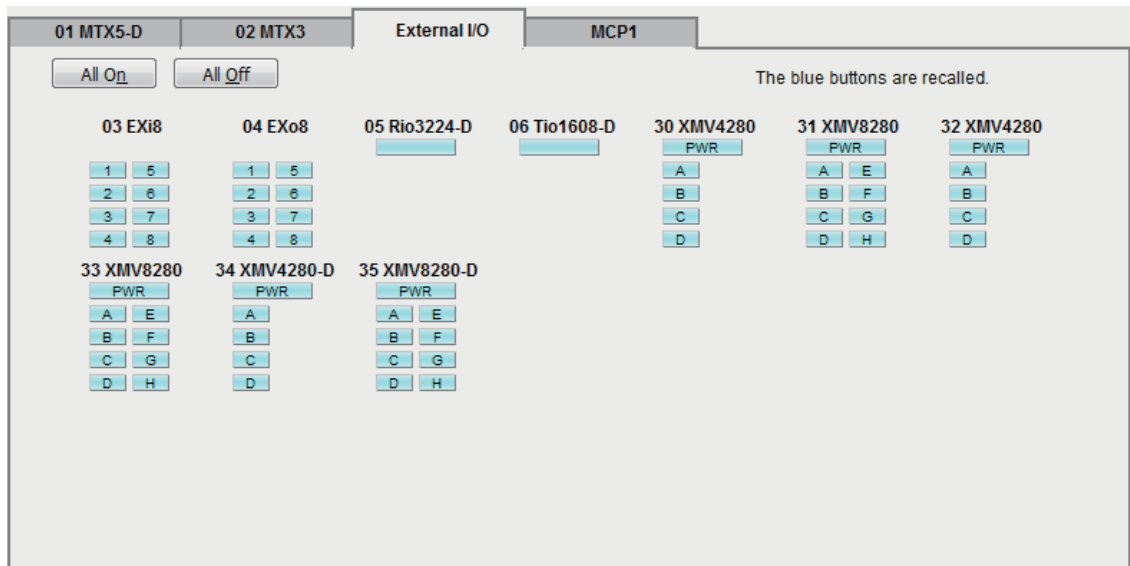

### ● [All On] button

Turns on (blue) all of the buttons of the currently selected tab. All parameters will be recalled.

### ● [All Off] button

Turns off (white) all of the buttons of the currently selected tab. None of the parameters will be recalled.

### ● Parameter select buttons

The parameter select buttons are shown for each device (UNIT ID, device name). If these buttons are on, the parameters included in the buttons will be recalled for each channel. The [PWR] button corresponds to the power on/standby status of the device, and the alphabetical or numeric buttons correspond to the channels of each device.

In the case of the R series (AD/DA) or Tio1608-D, turning the button on will recall the HA parameters for each unit.

■ **[MCP1] tab**

Here you can choose the MCP1 unit for which to make Recall Filter settings.

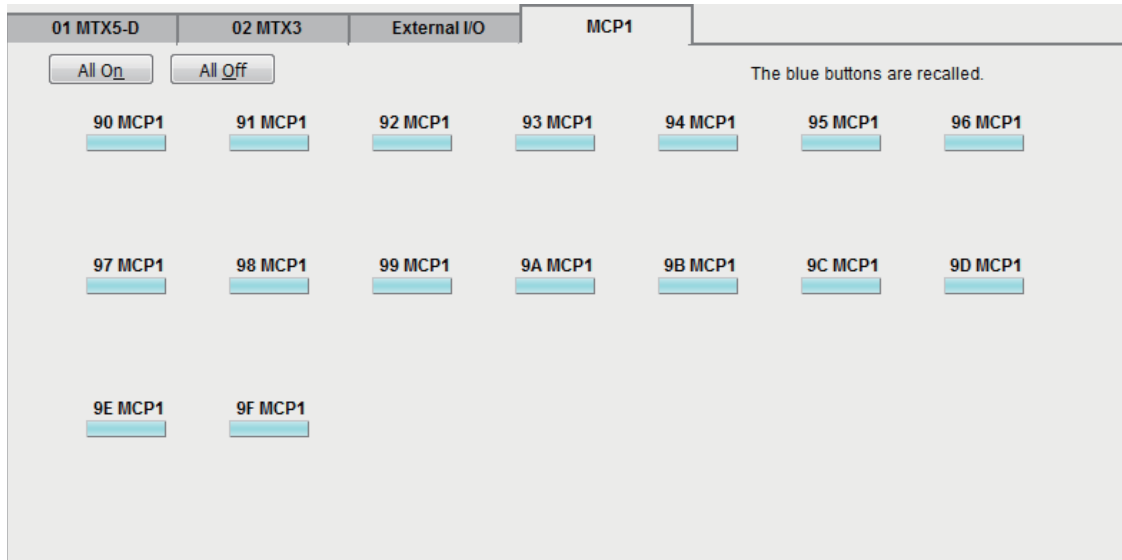

● **[MCP1] button**

If this is on, the parameter assignments of the MCP1 connected to the MTX will be recalled.

# Chapter 7. Dialog boxes/Software applications

This chapter explains the dialog boxes and applications that you can open from the menu bar or tool bar.

## □ “Startup” dialog box

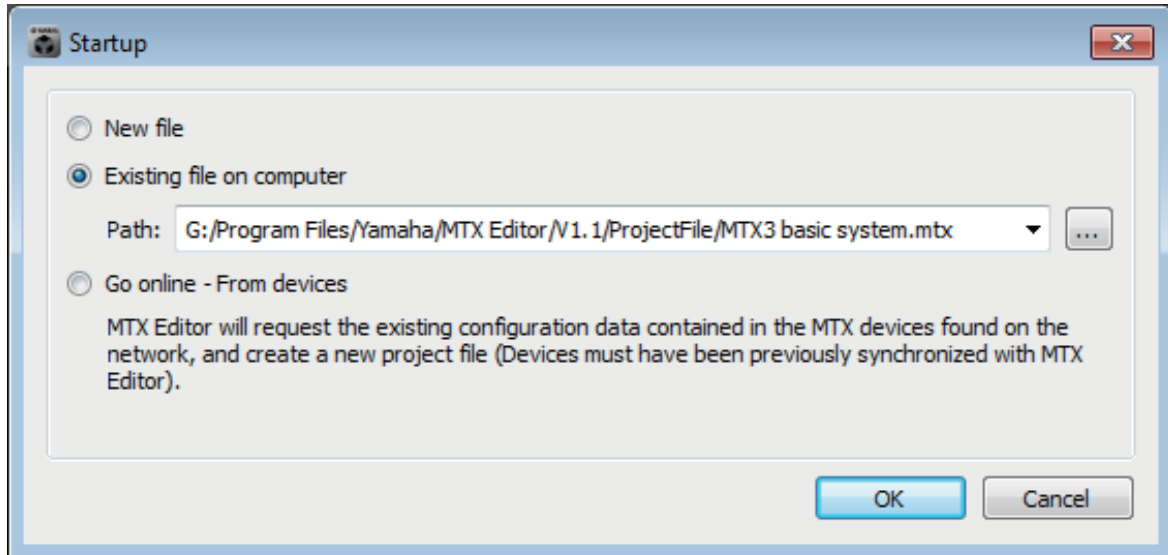

This will appear when you start MTX-MRX Editor.

### ● [New file] option button

When you click the [OK] button, the “Device Configuration Wizard” dialog box will appear.

### ● [Existing file on computer] option button

When you click the [OK] button, the selected file will open. If a PIN code has been assigned, you will be asked to enter the PIN code.

### ● [Go online – From devices] option button

When you click the [OK] button, the MTX/MRX system settings will be loaded from the currently-operating MTX/MRX units in the network, allowing you to create a project file.

In order for the settings to be loaded, you must be connected to an MTX/MRX unit with which MTX-MRX Editor has previously been “online.” If a PIN code has been assigned to the device, you will be asked to enter the PIN code.

### ● [OK] button

Executes the operation that is selected by the option button.

## □ “Network Setup” dialog box

Here you can select the network interface card of the computer that will be used to communicate with the MTX/MRX (subsequently called “the network card”).

**NOTE** *If you’re not using a DHCP server, fix the IP address of your computer’s network card. We recommend the following settings.  
IP address: 192.168.0.253  
Subnet mask: 255.255.255.0*

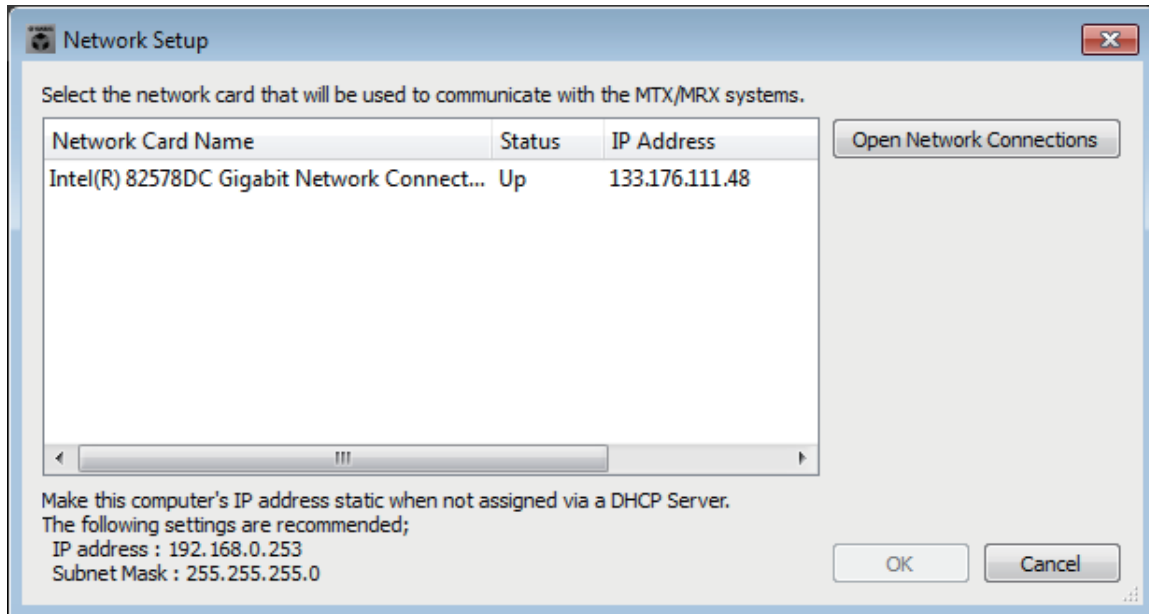

If you are not connected to the network, click the [Cancel] button to close the dialog box.

- **Network Card Name**

Shows the name of the network card.

- **Status**

Shows the status of the network card (Up or Down).

A network card for which this shows “Down” cannot be selected.

- **IP Address and Subnet Mask**

Shows the IP address and subnet mask assigned to the network card.

If there is no DHCP server and the IP address has not been assigned even though the setting of the network card is “Obtain IP address automatically,” this will show “0.0.0.0”.

This will also show “0.0.0.0” if the network card is not physically connected.

- **[Open Network Connections] button**

Opens the control panel “Network Connections.” Use this when you want to change the IP address of the network card.

- **[OK] button**

Updates the settings and closes the dialog box.

- **[Cancel] button**

Closes the dialog box without updating the settings.

## □ “Device Information” dialog box

Lists the devices on the network, allowing you to update their firmware and change their IP address.

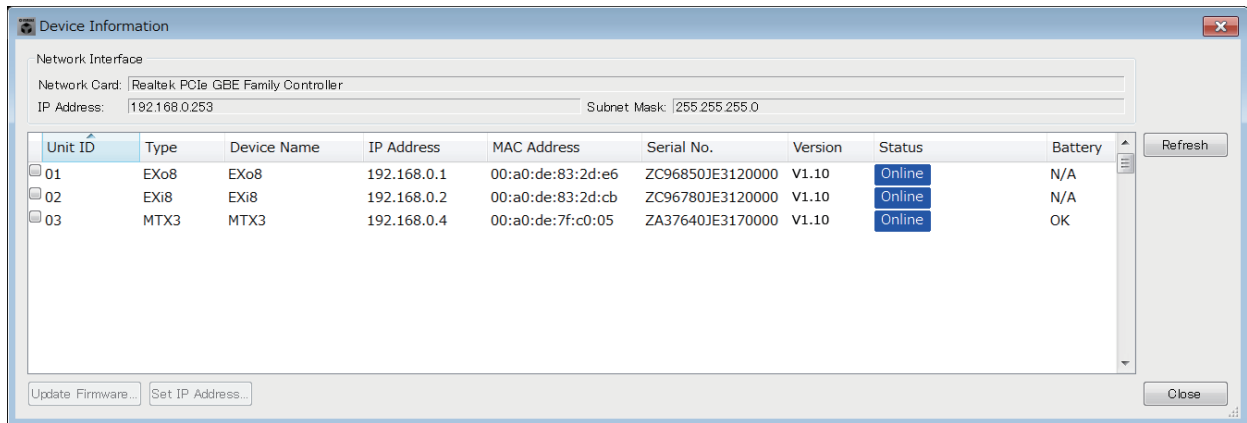

### ● Network Interface

Shows the name/IP address/subnet mask of the network card currently selected in the “Select Network Interface Card” dialog box.

### ● Device list

- Identify button

When you press this button located at the left of the UNIT ID, the indicators of the corresponding device will flash for five seconds.

- Unit ID

Shows the UNIT ID of the device.

If there is a UNIT ID conflict, this is indicated as follows.

	Unit ID	Type	Device Name	II
<input type="checkbox"/>	⚠ 02	XMV4140	XMV4140	
<input type="checkbox"/>	03	XMV4140	XMV4140	
<input type="checkbox"/>	01	MTX3	MTX3	
<input type="checkbox"/>	⚠ 02	MTX3	MTX3	1'
<input type="checkbox"/>	04	XMV4140	XMV4140	

- Type

Shows the model name of the device (except for digital control panels).

- Device Name

Shows the device name. This name can be edited in DEVICE NAME, which is located in the [Device] tab at the bottom of the Project screen.

- IP Address/MAC Address

Shows the IP address and MAC address that are specified for the device.

- Serial No.

Shows the serial number of the device.

- Version

Shows the firmware version.

- Status

Shows the online or offline status.

When updating a device, the progress is shown.

- **Battery**

Shows the remaining battery amount for a device that contains a battery.

**EMPTY:** The remaining amount is 0–0.5V. Immediately stop using the unit, and contact a Yamaha service center.

**Low:** The remaining amount is 0.5–2.5V. Contact a Yamaha service center as soon as possible.

**OK:** The remaining amount is 2.5–3.5V. There is no problem.

**N/A:** The device does not contain a battery.

- **[Update Firmware] button**

Updates the firmware.

Click this button to open the ["Update Firmware" dialog box](#).

- NOTE**
- If the "Select Folder" dialog box opens, select the folder that contains the update file, then click the [OK] button.
  - To update the firmware of the R series (AD/DA) or Tio1608-D, use the Windows software application R Remote.

- **[Set IP Address] button**

Specifies the device's IP address and subnet mask.

When you click this button, the ["IP Address" dialog box](#) will appear.

- **[Refresh] button**

Searches again for devices on the network.

This cannot be clicked while an update is in progress.

- **[Close] button**

Closes the dialog box.

This cannot be clicked while an update is in progress.

## “Update Firmware” dialog box

This dialog box lets you update the firmware of a unit such as an MTX/MRX or XMV. For Dante units such as the MTX5-D and the XMV8280-D, there may be cases in which the Dante firmware needs to be updated. For details on how to update the Dante firmware, refer to the “MTX/MRX system Firmware Update Guide.”

- NOTE**
- In some cases, updating may cause data to no longer be compatible. Save the latest project file before you update. After you update, use the most recent version of MTX-MRX Editor to open the latest project file.
  - To update the firmware of the R series (AD/DA) or Tio1608-D, use the Windows software application R Remote.

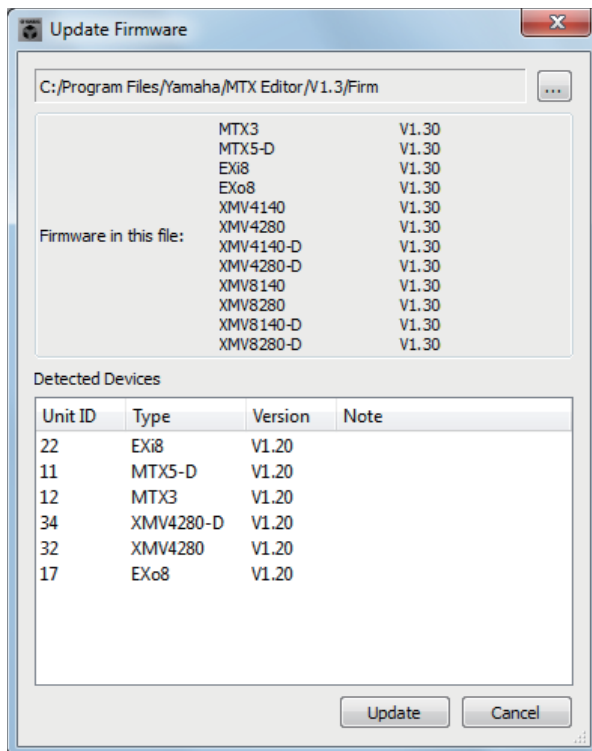

● **File**

Displays the .fup files that are in the folder containing the update file shown in the “Firmware in this file” section.

● **[...] button**

Click this button to select an update file. Click this button to select an update file. Clicking this button opens the “Select Folder” dialog box; select an .fup file.

● **Firmware in this file**

Shows firmware versions resident in the folder for each device.

● **Detected Devices**

Shows detected devices.

**Unit ID**..... Shows the UNIT ID of the device.

**Type**..... Shows the model name of the device.

**Version**..... Shows the firmware version of the device.

**● [Update] button**

Executes the update.

If an update file does not exist in the selected folder, this button will be dimmed and unavailable.

**● [Cancel] button**

Cancels the update and closes the dialog box.

**■ Update procedure**

All applicable devices can be updated at the same time.

**NOTE** *If there is an MTX/MRX unit with an assigned PIN code that differs from the project, you'll need to enter the PIN code.*

**1. For all applicable devices in the MTX/MRX system, turn DIP switches 7 and 8 OFF (RESUME mode).**

**2. Turn on the power of all applicable devices in the MTX/MRX system.**

**3. In the "Device Information" dialog box, click the [Update Firmware] button.**

If the "Select Folder" dialog box opens, select a folder that contains the update file, then click the [OK] button.

**4. The "Update Firmware" dialog box will appear.**

This shows the firmware versions resident in the folder. If you select the other folder, click the [...] button.

**5. Click the [Update] button to execute the update.**

During the update, the indicators of the devices will flash.

**NOTE** *Do not turn off the power of the devices while the update is being executed.*

**6. When the update is completed, the indicators of the applicable devices will light.**

When the update is completed, the devices will restart automatically.

**NOTE** *If the [ALERT] indicators of the applicable devices are flashing, the update has failed due to an error. The front panel [PRESET] display will show an error number; refer to the alert list in the appendix, and take the appropriate action.*

**7. Close the "Device Information" dialog box.**

When the update has ended successfully, the devices will restart, and the devices in the MTX/MRX system will reappear in MTX-MRX Editor's Project window.

## “IP Address” dialog box

Here you can set the device’s IP settings.

As the device’s settings, we recommend that you set “IP SETTINGS” to “UNIT ID” or “STATIC IP (Auto),” and set the computer’s IP address to “192.168.0.253” and its subnet mask to “255.255.255.0”

Editing is not possible while online.

In order to use MTX-MRX Editor to control MTX/MRX systems of differing subnets, it is necessary to operate the devices using unique IP addresses. For details, refer to [“Settings for controlling devices across subnets”](#).

**NOTE** *If a PIN code has been assigned, you will be asked to enter the PIN code. Devices whose PIN could not be unlocked do not appear in the device list, and their settings cannot be edited.*

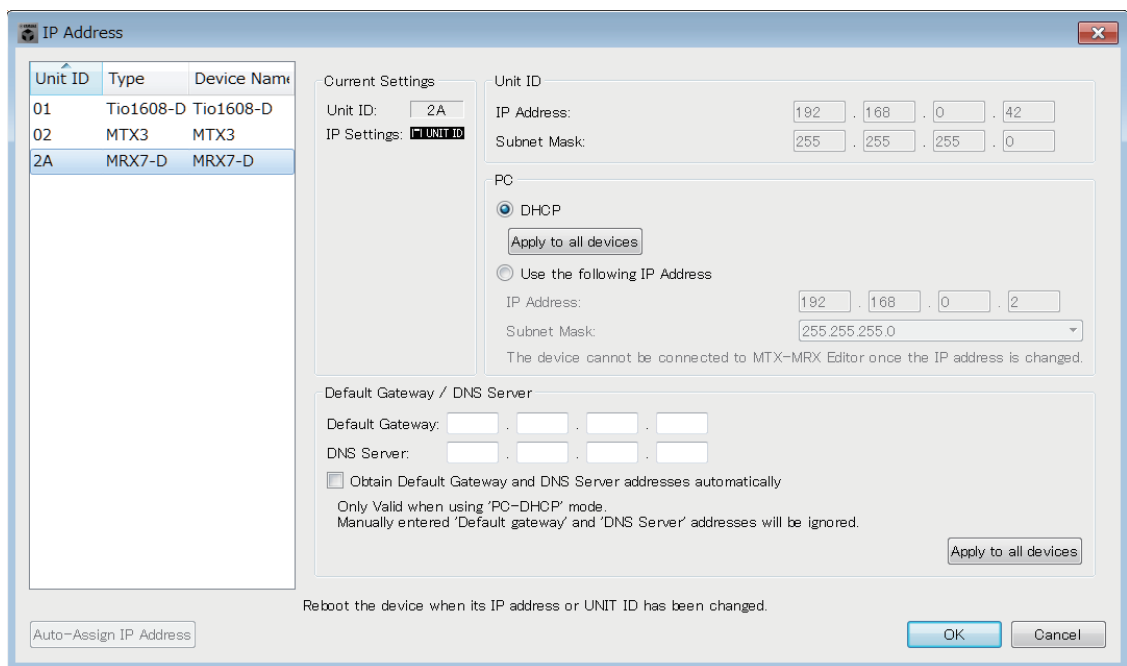

If you want to fix the device’s IP address and subnet mask, make the following settings in this dialog box.

- 1.** Set the computer’s IP address to “192.168.0.253” and the subnet mask to “255.255.255.0”.
- 2.** As the device’s settings, set “IP SETTINGS” to “UNIT ID” or “STATIC (IP) (Auto),” set the UNIT ID of all devices to something other than FD so that none of the devices conflict, and then power-on the devices.
- 3.** From the list in the left of the “IP Address” dialog box, select the device that you want to edit.
- 4.** In the “IP Address” dialog box, select the [Use the following IP Address] option button (specify a fixed IP address for the device).
- 5.** Specify values for [IP Address] and [Subnet Mask].
- 6.** Click the [OK] button.
- 7.** As the device’s setting, specify either PC mode or STATIC IP (MANUAL).
- 8.** Power-off the device, wait about ten seconds, and then turn the power on.

**9. In the "Device Information" dialog box, click the [Refresh] button.**

Verify that the device's IP address has been changed.

**HINT** *If you want to change the setting of multiple devices, repeat steps 3 through 5, and then proceed to step 6 and following.*

**● Device list**

Shows the devices on the network. When you click this, the settings of the current device are shown in the right, allowing you to edit them.

**● Current Settings**

Shows the UNIT ID and IP Setting that are specified for the unit.

**● Unit ID/Static IP(Auto)**

If the unit's IP Setting is "UNIT ID" or "STATIC IP (Auto)," the IP address and subnet mask are shown.

**● PC/Static IP(Manual)****○ [DHCP] option button (MTX/MRX system devices only)**

Choose this if you want the DHCP server to set the IP address.

If there is no DHCP server, the IP address will be set to [0.0.0.0]. To solve this problem, check that the DHCP server is connected. Alternatively, use the rear panel DIP switches of the unit to set IP Setting to [UNIT ID] (the mode in which the IP address will be generated from the UNIT ID).

**○ [Apply to all the devices] button (MTX/MRX system devices only)**

Sets all devices shown in the device list to DHCP mode.

**○ [Use the following IP Address] option button (MTX/MRX system devices only)**

If you choose this, the IP address and subnet mask specified here will be used.

**○ IP Address/Subnet Mask**

Here you can specify the device's IP address and subnet mask.

Set the IP address so that it does not conflict with the IP address of the computer or of any other device.

**NOTE** *The following IP addresses cannot be specified.*  
192.168.0.0 - Use is prohibited because it conflicts with the network address  
192.168.0.255 - Use is prohibited because it conflicts with the broadcast address

The following subnet masks can be selected.

128.0.0.0	255.255.128.0
192.0.0.0	255.255.192.0
224.0.0.0	255.255.224.0
240.0.0.0	255.255.240.0
248.0.0.0	255.255.248.0
252.0.0.0	255.255.252.0
254.0.0.0	255.255.254.0
255.0.0.0	255.255.255.0 (default value)
255.128.0.0	255.255.255.128
255.192.0.0	255.255.255.192
255.224.0.0	255.255.255.224
255.240.0.0	255.255.255.240
255.248.0.0	255.255.255.248
255.252.0.0	255.255.255.252
255.254.0.0	
255.255.0.0	

- **Default Gateway (other than MTX/MRX system devices)**  
Specifies the IP address of the default gateway.

● **Default Gateway / DNS Server (MTX/MRX system devices only)**

- **Default Gateway**  
Specifies the IP address of the default gateway.
- **DNS Server**  
Specifies the IP address of the DNS server.
- **[Obtain Default Gateway and DNS Server address automatically] check box** If this is checked, the IP addresses of the default gateway and DNS server are obtained automatically. The above IP address settings for the default gateway and DNS server are ignored.
- **[Apply to all devices] button**  
Specifies the same default gateway and DNS server settings for all devices shown in the device list.

● **[Auto-Assign IP Address] button**

Click this to open the “Auto-Assign IP Address” dialog box.

● **[OK] button**

Transmits the settings to the device, and closes the dialog box.

If the device’s IP Setting is [PC] and you’ve changed the IP address, communication will be temporarily interrupted.

● **[Cancel] button**

Discards the settings and closes the dialog box.

**NOTE** If the device’s “IP SETTINGS” is set to “UNIT ID” or “STATIC IP (Auto),” communication will not be possible if the network address settings differ between the computer and the unit. Be sure to set the computer’s network address to match the network address of the unit. If you don’t know the network address of the unit, we recommend that you use the unit’s rear panel DIP switch to set IP Setting to [UNIT ID].

## “Auto-Assign IP Address” dialog box

Information such as the IP address assigned to devices placed in MTX-MRX Editor using the “Match Devices by IP Address” dialog box is applied to the “IP Address” dialog box in a single operation.

For details, refer to “[Settings for controlling devices across subnets](#)” in the appendix.

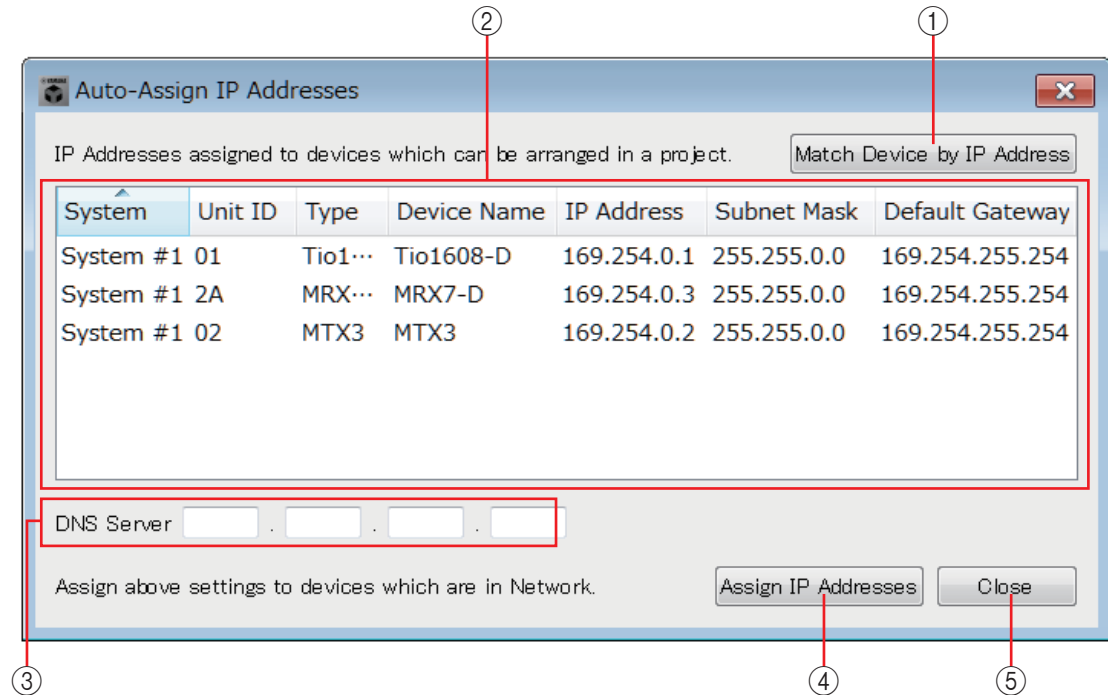

① **[Match Device by IP Address] button**

Click this to open the “[Match Device by IP Address](#)” dialog box.

② **Device list**

This shows information for the IP settings that are specified for the devices placed in MTX-MRX Editor using the “Match Devices by IP Address” dialog box.

③ **DNS Server**

Specifies the DNS server.

④ **[Assign IP Addresses] button**

Applies the information shown in the device list and the DNS Server settings to the “IP Address” dialog box. Even if the [DHCP] option button is selected in the “IP Address” dialog box, the [Use the following IP Address] option button is switched to the selected state.

⑤ **[Cancel] button**

Closes the dialog box.

## ❑ “Match Devices by IP Address” dialog box

Switches to a mode in which MTX-MRX Editor identifies devices on the network by their IP address.

If you want to control an MTX/MRX system that is on a different subnet than MTX-MRX Editor, make settings here.

For details on the procedure for settings, refer to “[Settings for controlling devices across subnets](#)”.

The following things are not possible for devices that are on different subnets.

- Preset Link
- Dante audio communication

Set the IP addresses so that they are unique for the entire communication path. If devices of the same IP address exist on the communication path, they might not be distinguishable.

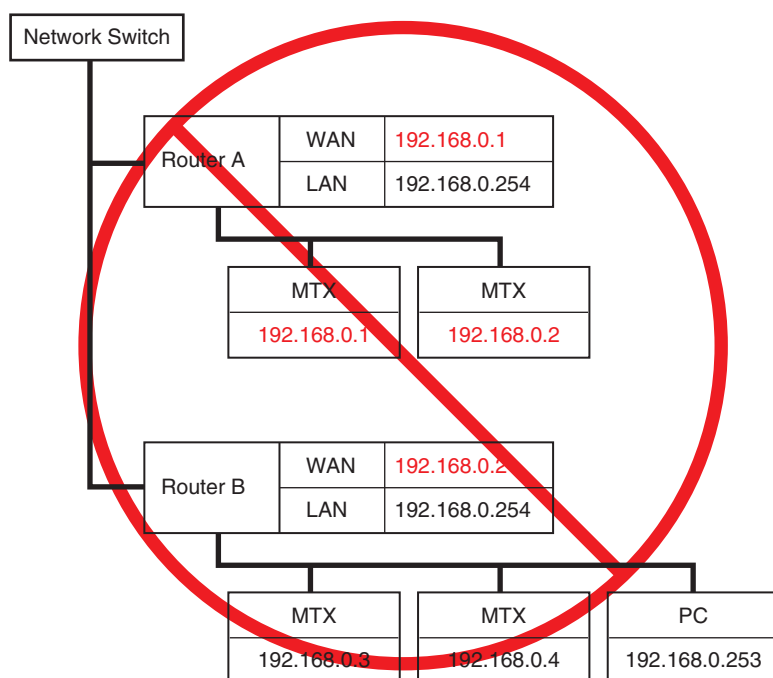

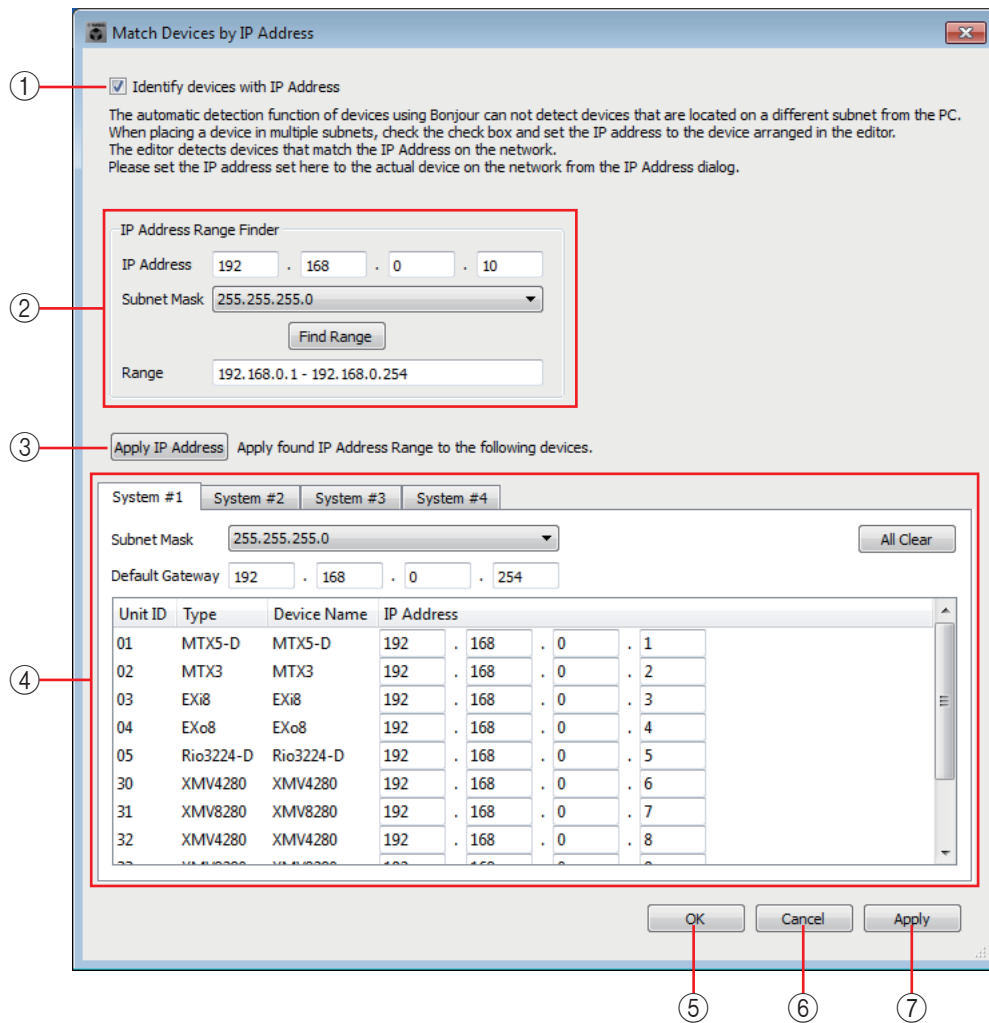

① **[Identify devices with IP Address] check box**

If this check box is selected, devices are distinguished by their IP address, not their UNIT ID.

② **“IP Address Range Finder” area**

If it is OK for the IP addresses to be consecutive, you can use this to calculate the IP addresses for assignment.

- **[IP Address]**  
Enter the IP address that you want to use.
- **[Subnet Mask]**  
Select the subnet mask. For the subnet masks that can be selected, refer to the “IP Address” dialog box.
- **[Find Range] button**  
When you click this, the range that can be specified is calculated from the IP address and subnet mask that you input.
- **“Range”**  
Shows the calculated range of IP addresses.

③ **[Apply IP Address] button**

When you click this, the IP address calculated in the “IP Address Range Finder” area is applied to the devices in the system tab.

**④ System tabs**

Here you can view and edit the settings of the devices in the system.

- **[Subnet Mask]**  
Select the subnet mask. For the subnet masks that can be selected, refer to the "IP Address" dialog box.
- **[Default Gateway]**  
Enter the IP address of the default gateway within the subnet.
- **Device list**  
Enter the IP address of the devices in the system.
- **[All Clear] button**  
Deletes the IP address information of the devices.

**⑤ [OK] button**

Updates the settings and closes the dialog box.

**⑥ [Cancel] button**

Closes the dialog box without updating the settings.

**⑦ [Apply] button**

Updates the settings.

## □ “MTX Configuration” dialog box

Here you can specify input/output settings for each device, such as MTX/MRX input ports, output channels, and matrix buses.

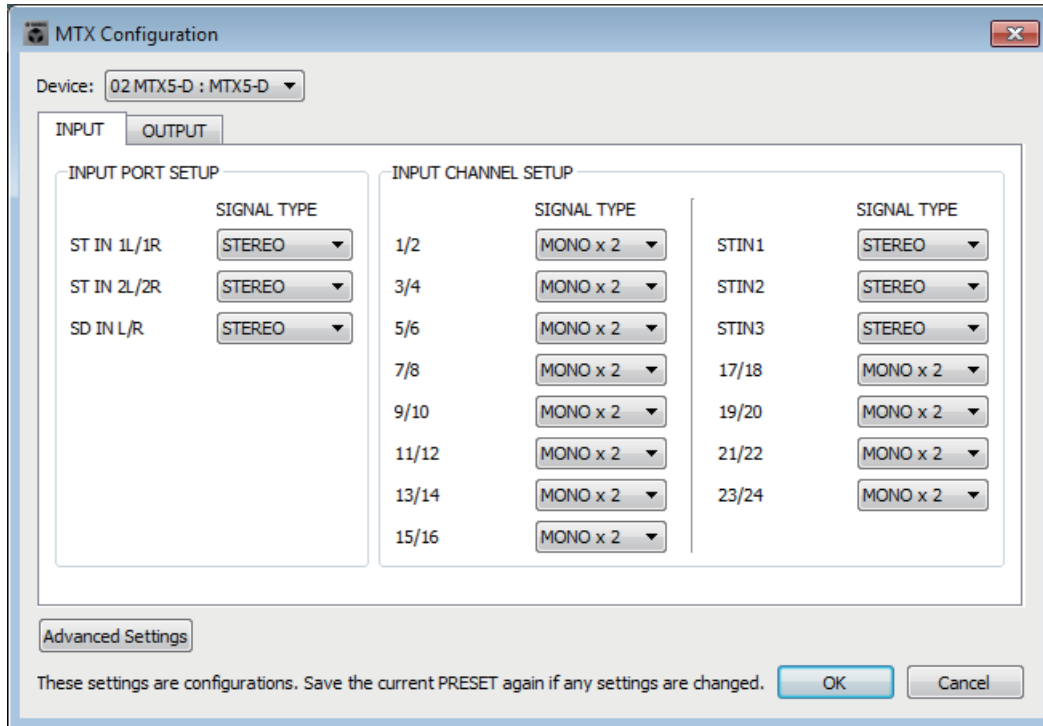

**NOTE** Since these settings are not included in a preset, they cannot be changed via the Preset Recall function.

● **Device:**

Selects an MTX unit within the MTX/MRX system.

From the left, this shows the “UNIT ID,” “Type (model name of the device),” and “Device Name (name of the device).”

● **[Advanced Settings] button**

The “Advanced Settings” dialog box will appear.

● **[OK] button**

Saves the settings and closes the dialog box.

● **[Cancel] button**

Discards the settings and closes the dialog box.

● **[INPUT] tab**

In this tab, you can make settings related to inputs.

• **INPUT PORT SETUP**

Here you can specify the inputs to the stereo input ports.

**STEREO** .....The stereo signal will be input without change.

**SUM** .....The L and R inputs will be summed to a single channel.  
There will be one input to the input patch.

• **INPUT CHANNEL SETUP**

Here you can make settings for the input channels. The settings here will affect the input channel strip of the “MAIN” screen.

**MONO x2**.....The input channels will be treated as two monaural channels.

**STEREO** .....The input channels will be treated as a single stereo pair.

● **[OUTPUT] tab**

In this tab, you can make settings related to outputs.

• **MATRIX BUS SETUP**

Here you can make settings for the matrix buses. These settings will affect the “MATRIX” screen.

**MONO x2**.....The input channels will be treated as two monaural channels.

**STEREO** .....The input channels will be treated as a single stereo pair.

**NOTE** *If the MTX/MRX system's YDIF mode is Cascade mode, the parameters will be shared in common by all MTX units in the MTX/MRX system.*

• **CASCADE MODE**

Here you can specify the zone input source for each matrix. This setting cannot be made in Distribution mode.

**On**

The matrix out of all MTX units will be mixed for each matrix. That mixed signal will be used as the input to the zone.

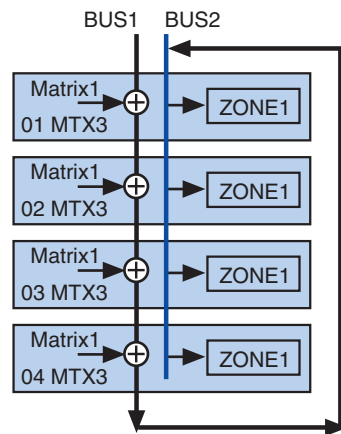

**Off**

Instead of using the mix from the bus, the matrix out will be used as the input for the zone.

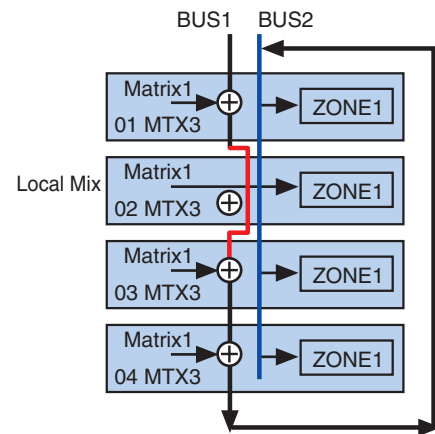

• **OUTPUT CHANNEL SETUP**

Here you can specify the type of output channel speaker processor (1WAYx2 or 2WAY). The settings here will affect the channel strip of the “MAIN” screen.

## “Advanced Settings” dialog box

Here you can specify the matrix pan mode (PAN or Blend). For both input and output, this can be specified only for stereo.

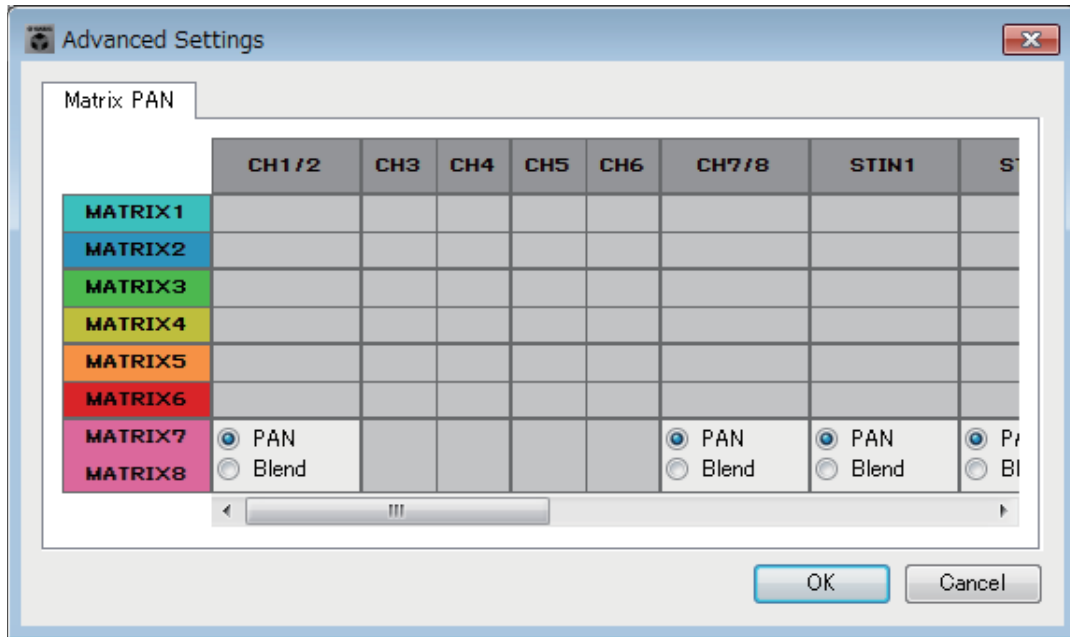

If you choose [Blend], the right and left channels of the stereo audio will be mixed while preserving the sense of stereo. For example in some old stereo recordings, completely different audio is recorded on the left and right channels; if such audio is played via a stereo background music system, it may produce the impression that different music is playing in different areas. “Blend” is effective in mitigating this.

- **[OK] button**

Saves the settings and closes the dialog box.

- **[Cancel] button**

Discards the settings and closes the dialog box.

## □ “Dante Information” dialog box

This shows Dante-related settings for Dante units such as the MTX5-D or XMV8280-D.

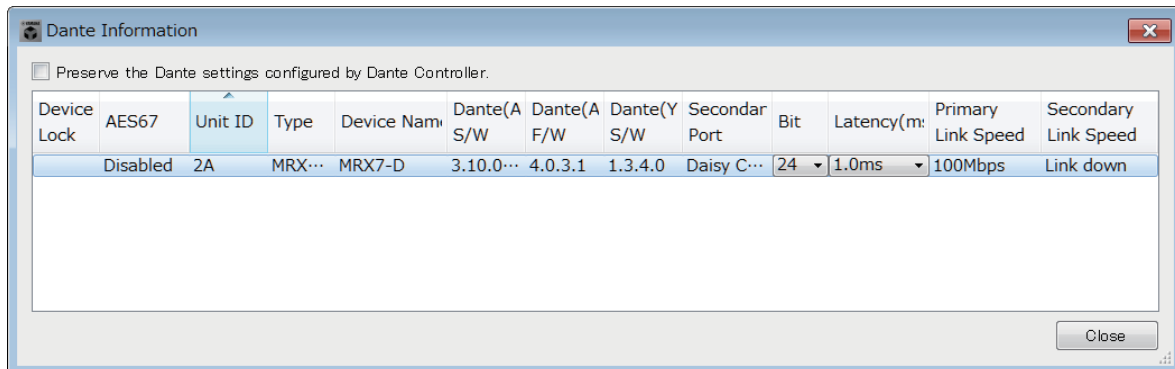

- **[Preserve the Dante settings configured by Dante Controller] check box**

Select this check box if you’re using Audinate Corporation’s Dante Controller to set up the Dante network. The settings of Dante Controller will take priority over the settings made in MTX-MRX Editor. If this check box is cleared, you’ll be able to use MTX-MRX Editor to make Dante network settings within the project.

- **[Device Lock]**

If the unit is set to Device Lock by Dante Controller, a lock icon is shown, and the unit is excluded from editing.

- **[AES67]**

This indicates “Enabled” if the device is in AES67 mode.

- **[UNIT ID]**

Indicates the UNIT ID of the device.

- **[Type]**

Indicates the model name of the device.

- **[Device Name]**

Shows the device name. This name can be edited in DEVICE NAME, which is located in the [Device] tab at the bottom of the Project screen.

- **[Dante(A) S/W]/[Dante(A) F/W]/[Dante(Y) S/W]**

Shows the version of the Dante firmware.

- **[Secondary Port]**

Shows the [SECONDARY PORT] settings of the DIP switch.

- **[Bit]**

Indicates the bit rate. The setting can be changed when offline.

- **[Latency (ms)]**

Indicates the latency in millisecond units. The setting can be changed when offline.

- **[Primary Link Speed]/[Secondary Link Speed]**

Indicates the communication speed settings of the Dante ports. If no other device is connected to a port, or if the cable is broken, this will indicate “Link Down.”

- **[Close] button**

Closes the dialog box.

## □ “Word Clock” dialog box

Here you can edit the word clock settings of the MTX/MRX system. Normally, these will be set to the optimal values when you use the “Device Configuration Wizard” dialog box to create the configuration. If you want to specify a Mini-YGDAI card as the word clock master etc., make settings in this dialog box.

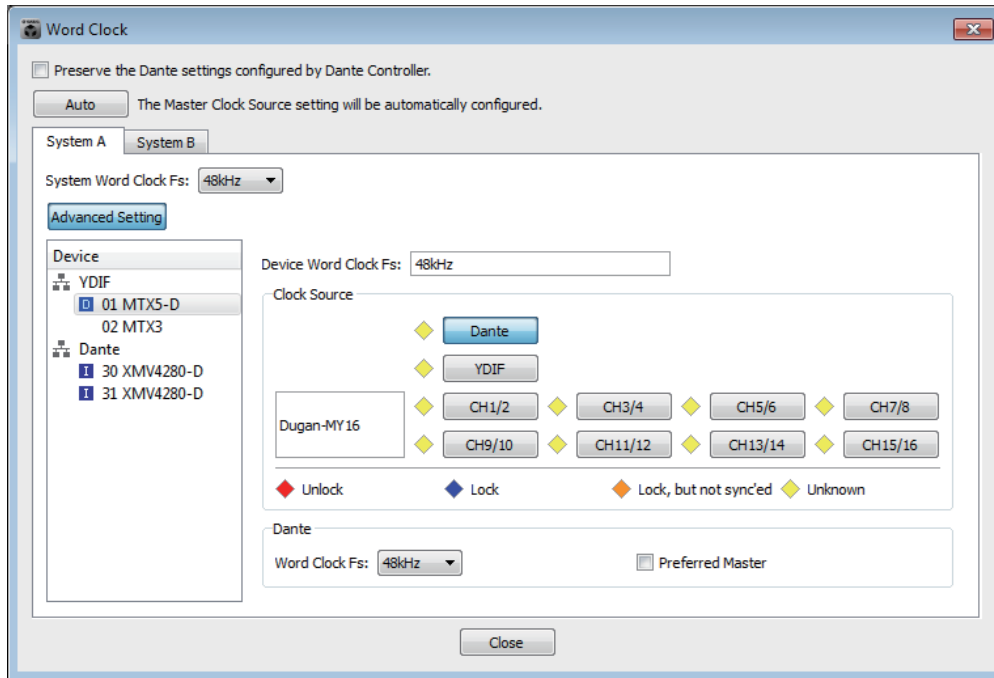

### ● [Preserve the Dante settings configured by Dante Controller] check box

Select this check box if you’re using Audinate Corporation’s Dante Controller to set up the Dante network. The settings of Dante Controller will take priority over the settings made in MTX-MRX Editor. If this check box is cleared, you’ll be able to use MTX-MRX Editor to make Dante network settings within the project.

### ● [Auto] button

Sets the word clock and master clock for all MTX/MRX systems in the project. This is available only when offline.

### ● System select tabs

These select the MTX/MRX system whose word clock you will set.

### ● [System Word Clock Fs:] box



This specifies the word clock of the MTX/MRX system.

### ● [Advanced Setting] button

This switches the display to a screen where you can make advanced settings. The illustration above shows the state when the [Advanced Setting] button has been clicked.

### ● [Device] list

This lists the devices whose word clock can be changed. Click the device whose detailed word clock settings you want to edit; the edit screen for that device will appear. The icon at the left of the UNIT ID indicates what is specified as the clock source.

Icon	Clock source
	Dante
	Internal
	Mini-YGDAL card
None	YDIF

**NOTE** The following devices are not shown.

- EXi8
- Exo8
- XMV units connected via YDIF
- XMV units connected via analog





● **[Device Word Clock Fs:]**

This indicates the word clock of the device. When online, this indicates the word clock value for the device. When offline, the indication will be as follows.

<b>MTX5-D/MRX7-D</b>	If DANTE is specified as the word clock source, this indicates the value specified by Dante [Word Clock Fs:]. Otherwise, this indicates “---”.
<b>MTX3</b>	If Internal 44.1 kHz or 48 kHz are selected, that value is shown. If YDIF is selected, this indicates “---”.
<b>Dante-compatible XMV</b>	This indicates “48 kHz”.

● **[Clock Source]**

Use these buttons to select the word clock source. A indicator showing the status is displayed at the left of buttons that can be selected. When offline the status cannot be detected, so all indicators will be yellow.

Indicator	Status
	Locked.
	Locked but not synchronized.
	Unlocked.
	The clock status cannot be detected because an external device is not connected or because there is no valid clock input.

● **[Dante]**

Specifies the Dante word clock. If the device is set to Device Lock by Dante Controller, a lock icon is shown, and settings cannot be made.

• **[Word Clock Fs:] box**

Indicates/specifies the word clock of the device. If the unit is set to Device Lock by Dante Controller, a lock icon is shown, and the unit is excluded from editing. If the unit is set to AES67 mode by Dante Controller, this indicates “48kHz,” and the unit is excluded from editing.

• **[Preferred Master] check box**

Selecting this check box will increase the probability that the device will become the clock master within the Dante network. Use this when the MTX/MRX system includes a Dante device that is not supported by MTX-MRX Editor, and you want to use the MTX/MRX system device as the clock master. If the unit is set to Device Lock by Dante Controller, the unit is excluded from editing.

● **[Close] button**

Closes the dialog box.

## □ “Clock” dialog box

The date and time of the computer are transmitted to each device connected to the MTX/MRX system every time it goes online, automatically updating the internal clock of each device. If you transmit the computer’s date and time information from this dialog box, the date and time will be updated on an MTX/MRX unit that is connected to the same network, regardless of online/offline status. The internal clock in devices other than the MTX/MRX will be updated by the MTX/MRX.

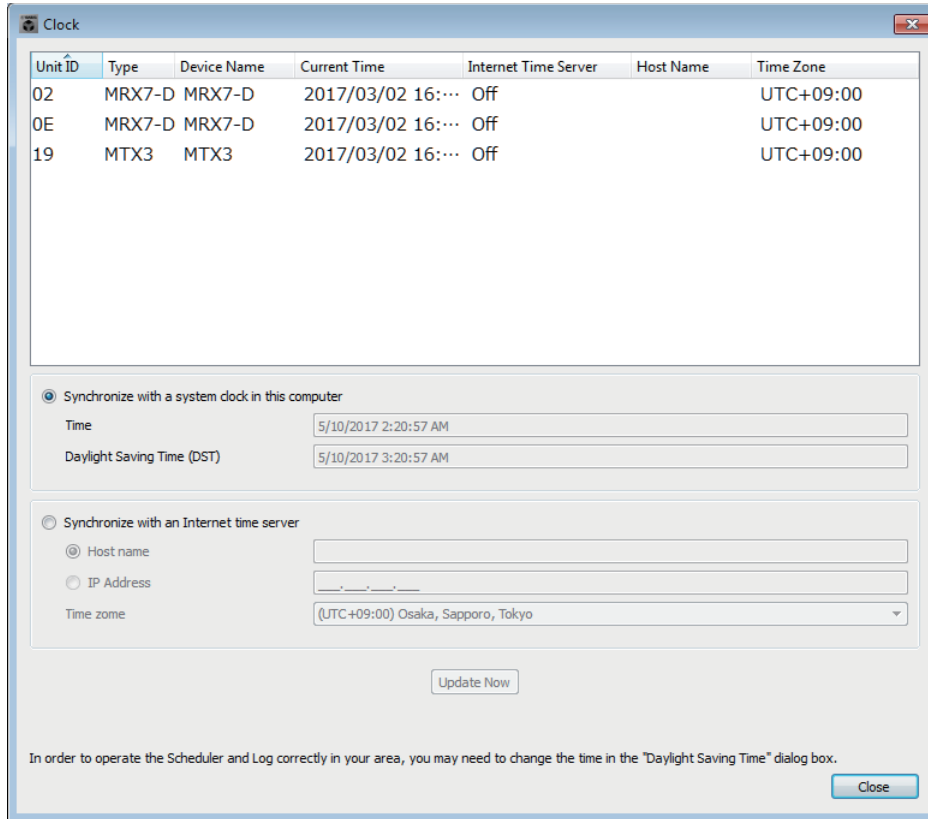

● **Unit ID**

Indicates the UNIT ID.

● **Type**

Indicates the type of device.

● **Device Name**

Indicates the device name.

● **Current Time**

Indicates the time information of the device.

● **Internet Time Server**

This is shown as On if the device is set to obtain time information from a time server; it is shown as Off if the device is set to not use a time server.

● **Host Name**

This shows the time server’s host name or IP address if the device is set to obtain time information from a time server.

● **Time Zone**

Indicates the time zone of the device.

**● [Synchronize with a system clock in this computer] option button**

If you select this option, the date and time of the computer's system clock will be sent out each time the system comes online, and the internal clock on the MTX/MRX will be automatically updated.

**• [Time]**

Shows the date and time of the computer system clock, ignoring the daylight saving time setting.

If this indication matches the date and time of the internal clock on the MTX/MRX, the time information on the MTX/MRX will synchronize with that of the computer.

**• [Daylight Saving Time(DST)]**

Shows the daylight saving time used on the computer. If daylight saving time has not been programmed, this field will display the message "Daylight Saving Time has not been executed."

**● [Synchronize with an Internet time server]**

If you select this and click the [Update Now] button, the internal clock of the MTX/MRX is updated using the time information from the specified time server. After this setting is made, the internal clock will synchronize with the time server every 24 hours. If any required field is not completed, time information may not be obtained. Be sure to enter an appropriate value in all non-grayed fields.

**Notice**

**If you plan to specify an external time server, configure an Internet connection, and in the IP Address dialog box, specify the [DNS server address] and [Default gateway] as appropriate for the connection environment.**

**If you specify an external time server, make sure that the server is reliable. If you specify an unreliable server, you may be exposed to certain risks, such as an infection by a computer virus.**

**• [Host name]**

If you select this option, enter the host name of the time server.

**• [IP Address]**

If you select this option, enter the IP address of the time server.

**• [Time zone]**

Set the local time difference from Greenwich Mean Time. The default setting is the computer's time zone.

**• [Update Now] button**

When you click this, the device's internal clock is updated according to the settings.

**● [Close] button**

Closes the dialog box.

## □ “Daylight Saving Time” dialog box

This specifies the daylight saving time setting of the MTX/MRX devices connected to the same network, regardless of their online/offline state.

- NOTE**
- Events that are assigned within two hours before or after the beginning or end of daylight saving time in the “Scheduler” dialog box will not be executed correctly.
  - When you create a new project, the daylight saving time setting from the computer’s “Date and Time” settings will be automatically shown in this dialog box.

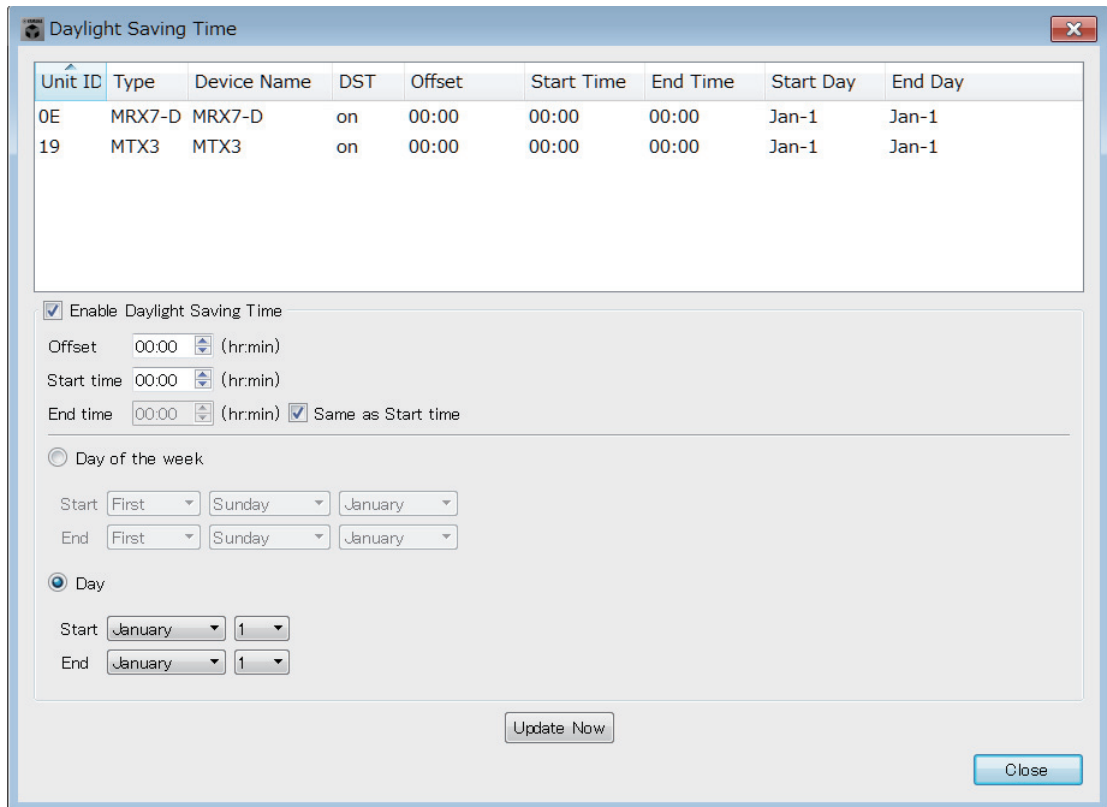

- **Unit ID**  
Indicates the UNIT ID.
- **Type**  
Indicates the type of device.
- **Device Name**  
Indicates the device name.
- **DST**  
This indicates On if daylight saving time is specified for the device; it indicates Off if daylight saving time is not specified.
- **Offset**  
Indicates the amount of time by which the device’s daylight saving time is earlier than standard time.
- **Start Time**  
Indicates the time at which daylight saving time starts for the device.
- **End Time**  
Indicates the time at which daylight saving time ends for the device.

**● Start Day**

Indicates the date on which daylight saving time starts for the device.

**● End Day**

Indicates the date on which daylight saving time ends for the device.

**● [Enable Daylight Saving Time] check box**

Daylight saving time will be enabled if this check box is selected.

**NOTE** *If the "Automatically adjust daylight saving time" check box is selected in the computer's "Date and Time" settings, you must also select the [Enable Daylight Saving Time] check box in the "Daylight Saving Time" dialog box.*

**• Offset**

Specifies the amount of time by which daylight saving time is earlier than standard time.

**• Start time**

Specifies the time when daylight saving time begins.

For example if you set Offset as 01:00 and Start time as 12:00, the clock will be set to 13:00 when the time reaches 12:00 of the day on which daylight saving time begins.

**• End time**

Specifies the time when daylight saving time ends. If this is the same as the start time, select [Same as Start time].

For example if you set Offset as 01:00 and End time as 12:00, the clock will be set to 11:00 when daylight saving time reaches 12:00 on the last day of daylight saving time. If the [Same as Start time] check box is selected, daylight saving time will automatically be cancelled and revert to standard time on the last day of daylight saving time at the time specified by the Start time.

**● Day of the week**

If this is on, the term of daylight saving time will be specified as a day of the week. Use Start and End to specify which day of which week will be the start and end of daylight saving time. For example to specify the first Sunday in April, choose "First," "Sunday," and "April"; to specify the last Sunday in October, choose "Last," "Sunday," and "October."

**● Day**

If this is on, the term of daylight saving time will be specified as a day of a month. Use Start and End to specify the dates that will be the start and end of daylight saving time.

**● [Update Now] button**

When you click this, the device's internal clock is updated according to the settings.

**● [Close] button**

Closes the dialog box.





## □ “Scheduler” dialog box

You can switch presets or play back a song or sound effect from an SD memory card at a previously specified date and time. Each such setting is called an “Event.”

### <Usage example 1>

#### Switching background music by time period

Here’s how you could switch the type of background music according to the time period, for example in a commercial establishment.

9:00	12:00	14:00	18:00	22:00
 Refreshing background music	 Energetic background music	 Peaceful background music	 Atmospheric background music	

### <Usage example 2>

#### Switching background music by day of the week

Here’s how you could switch the type of background music according to the day of the week or the times of business, for example in a commercial establishment.

- **Monday–Friday**

10:00	20:00
	Background music pattern 1

- **Saturday**

10:00	22:00
	Background music pattern 2

- **Sunday**

12:00	20:00
	Background music pattern 3

You can also specify exceptions, such as playing seasonal background music at Christmas, or stopping playback on days when the establishment is not operating.

- NOTE**
- If an event has been assigned, the [SCHEDULER] indicator on the MTX/MRX front panel will be lit yellow. One minute before the event occurs, the indicator will flash.
  - If more than one event is assigned at the same time, all events will run with one second of space between them. During this time, the [SCHEDULER] of the MTX/MRX’s front panel will continue flashing.
  - If the [Enable Daylight Saving Time] check box is selected in the “Daylight Saving Time” dialog box, events that have been scheduled within two hours before or after the start or end of daylight saving time will not be executed correctly.



You can assign up to 50 events and 50 exceptions.

● **[Month] button/[Day] button**

Switch the calendar between month or day views.

Month view

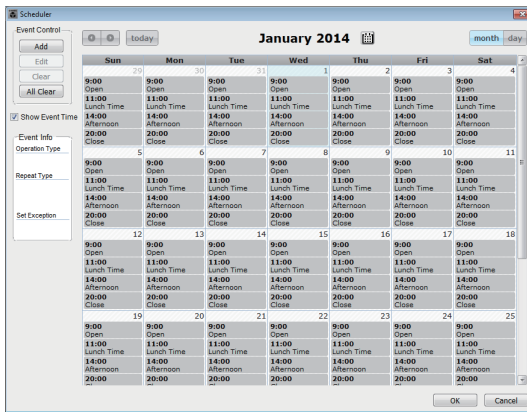

Day view

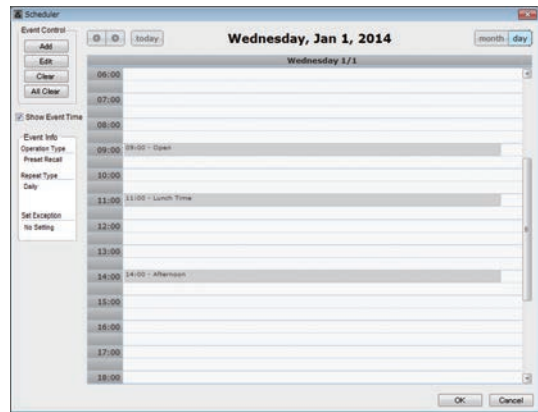

- In the calendar, double-click the date you want; the “Add Event” dialog box will appear, letting you add an event.
- Events other than repeating events can be moved by dragging and dropping them (in the month display you can move between days, and in the day display you can move between hours).
- In the month display, you can click the calendar icon to access a year/month selection screen.

● **[Today] button**

For the month view, displays this month’s calendar.  
 For the day view, displays today’s schedule.

**● [ < ]/[ > ] buttons**

For the month view, displays the previous or next month’s calendar.

For the day view, displays the previous or next day’s schedule.

**● Event Control****• [Add] button**

The “Add Event” dialog box will appear.

Here you can add an event.

**• [Edit] button**

The “Edit Event” dialog box will appear.

Here you can edit the contents of the currently selected event. If no event is selected, the button is dimmed.

**• [Clear] button**

Deletes the currently selected event. If no event is selected, the button is dimmed.

**• [All Clear] button**

Deletes all registered events.

**● [Show Event Time] check box**

If this is selected, the time of the event is shown in the month display.

**● Event Info**

This shows the information that was specified in the “Add Event” dialog box or “Edit Event” dialog box for the selected event.

**• OperationType**

Indicates the operation that will be executed when the event occurs.

**• RepeatType**

Indicates the frequency with which the event will occur.

**• SetException**

Indicates a date and time for which, as an exception, the event will not occur.

**● [OK] button**

Saves the settings and closes the dialog box.

**● [Cancel] button**

Closes the dialog box without saving the changes.

## “Add Event” dialog box / “Edit Event” dialog box

For details about settings that are unique to the MRX series, refer to “MRX Designer User Guide.”

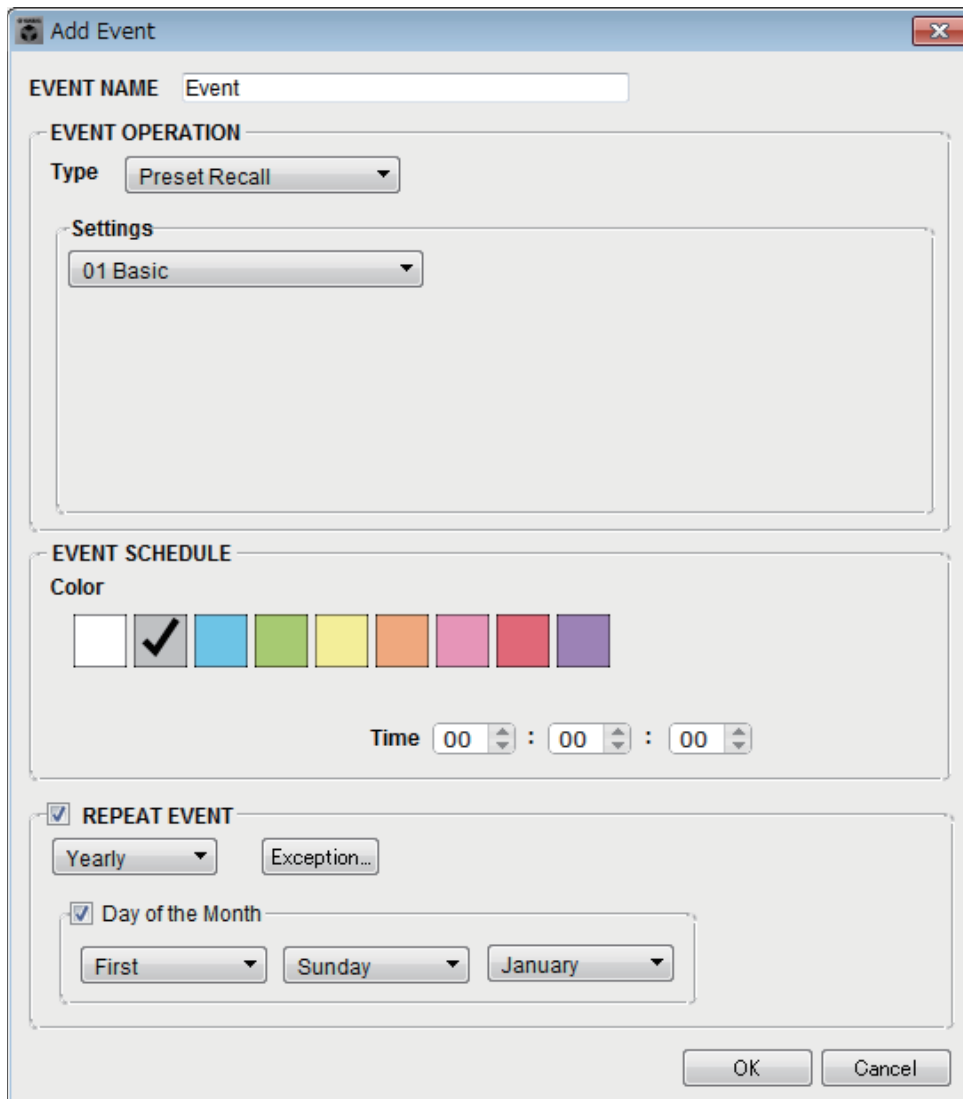

### ● EVENT NAME

Enter the name of the event.

### ● EVENT OPERATION

#### • [Type] box

Choose the operation that will be executed when the event occurs.

**NOTE** In the “Preset” dialog box operations such as GPI Out or SD Song Select & Play can be included in the preset. Choose GPI Out if you want to control an external device via [GPI OUT] without recalling a preset, or choose SD Song Select & Play if you want to change the audio file that will play.

**Preset Recall** ..... A preset will be recalled.

**GPI Out** ..... The [GPI OUT] connector will be controlled.

**SD Song Select & Play** ..... An audio file saved on the SD memory card will play or stop.

**Snapshot Recall** ..... Recalls the MRX7-D’s parameters. For details, refer to “MRX Designer User Guide.”

**Paging** ..... An audio message saved on the SD memory card will be played for the specified broadcast destination (ZONE).

- **Settings**

The contents will change depending on the event you chose in [Type] box.

**If you chose Preset Recall**

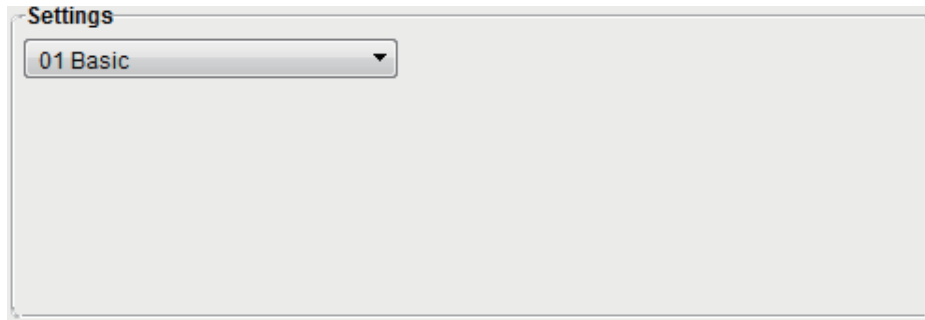

Select the preset that you want to recall.

**If you chose GPI Out**

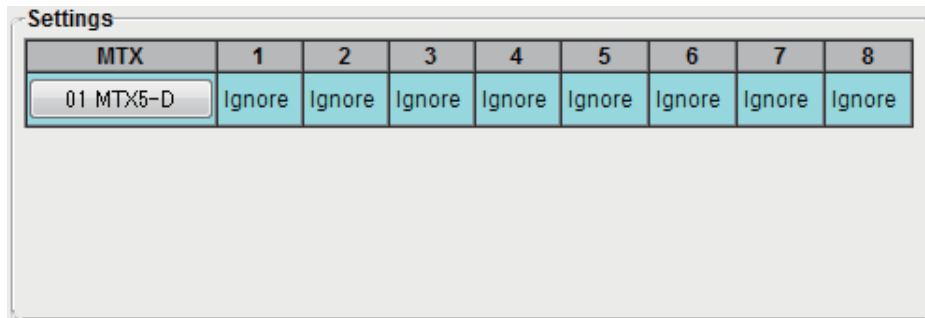

Specify the state of the GPI OUT connector when the event occurs for each MTX/MRX unit.

Click the button of the MTX/MRX unit that you want to set; the “GPI Out” dialog box will appear. Make settings in the same way as in the “Settings” dialog box of the “Preset” dialog box.

**If you chose SD Song Select & Play**

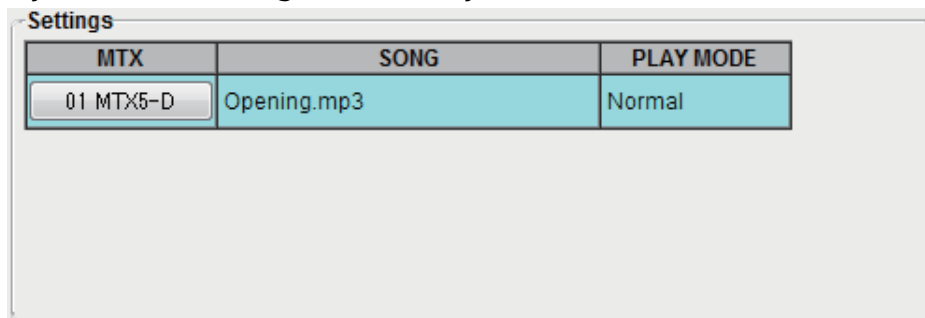

For each MTX/MRX unit, specify how the audio files saved on the SD memory card will play or stop when the event occurs.

Click the button of the MTX/MRX unit that you want to set; the “SD Play” dialog box will appear. Make settings in the same way as in the “Settings” dialog box of the “Preset” dialog box.

### If you chose Paging

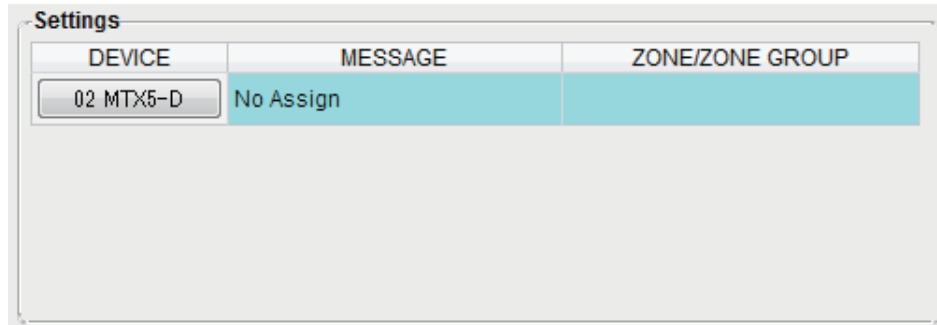

For each MTX/MRX unit, specify the ZONE/ZONE GROUP to which message files saved on the SD memory card will be broadcast when the event occurs.

Click the button of the MTX/MRX unit that you want to set; the “SD Message Select” dialog box will appear.

To use the Paging function, use the “ZONE” screen to specify the Paging and Zone Group, and use the “PGM1/PGX1” dialog box to specify chime and other settings.

### ● EVENT SCHEDULE

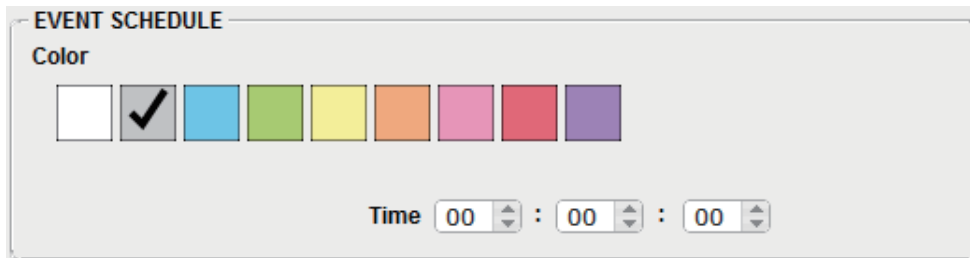

Specify the date and time at which the event will occur.

- **[Color] select switches**

Choose the color of the event shown in the calendar. By specifying a color, you can make it easier to distinguish certain types of event.

- **[Date]**

Specifies the date on which the event will occur. (year/month/day)

You can change the date either by inputting it directly or by clicking the calendar that appears when you click the calendar icon at the right.

Depending on the REPEAT EVENT setting described below, this might not be shown.

- **[Time]**

Specifies the time at which the event will occur. (hour:minute:second, in 24-hour time)

Click the hour/minute/second that you want to specify, and use the spin box or enter a value directly.

If you select REPEAT EVENT and specify the event frequency as “Hourly,” you’ll only be able to set the minutes and seconds.

● **[REPEAT EVENT]**

By selecting this check box you can specify a repeating event.

- **[Yearly]/[Monthly]/[Weekly]/[Daily]/[Hourly] boxes**  
Specify the frequency with which the event will occur.

- **Event start date and time**

Specify the date and time at which the event will occur repeatedly. The items that you can specify will depend on the frequency of the event.

**If the event frequency is [Yearly]**

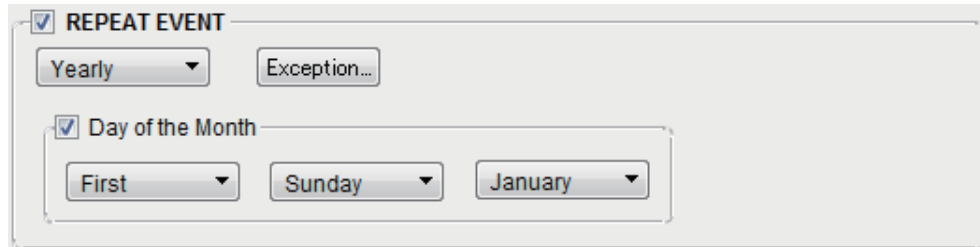

If [Day of the Month] is on, the event will occur each year at the date and time specified by “-month,” “1st/2nd/3rd/4th,” “day of the week,” and [Time].

If [Day of the Month] is off, the event will occur each year on the day selected in the calendar (shown in [Date]) at the time selected in [Time].

**If the event frequency is [Monthly]**

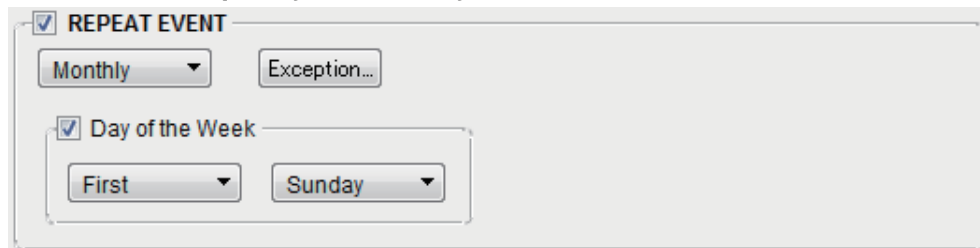

If [Day of the Week] is on, the event will occur each month at the date and time specified by “1st/2nd/3rd/4th,” “day of the week,” and [Time].

If [Day of the Week] is off, the event will occur each month on the day selected in the calendar (shown in [Date]) at the time selected in [Time].

**If the event frequency is [Weekly]**

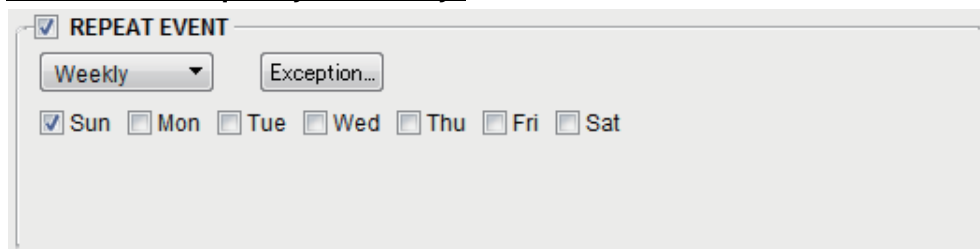

The event will occur each week on the selected day of the week at the time specified by [Time].

**If the event frequency is [Daily]**

The event will occur each day at the time (hour:minute:second) specified by [Time].

**If the event frequency is [Hourly]**

The event will occur each hour at the time (minute:second) specified by [Time].

● **[Exception] button**

The “Event Exception” dialog box will appear.

Here you can specify a date and time for which, as an exception, the repeating event will not occur.

● **[OK] button**

Saves the settings and closes the dialog box.

● **[Cancel] button**

Closes the dialog box without saving the changes.

■ **“Event Exception” dialog box**

Here you can specify a date and time for which, as an exception, the repeating event will not occur. The items that you can specify will depend on the frequency of the event.

- Example) - Don't play background music on Wednesday, when the establishment is closed.
- Play special background music only for the event that occurs on the third Sunday of every month.

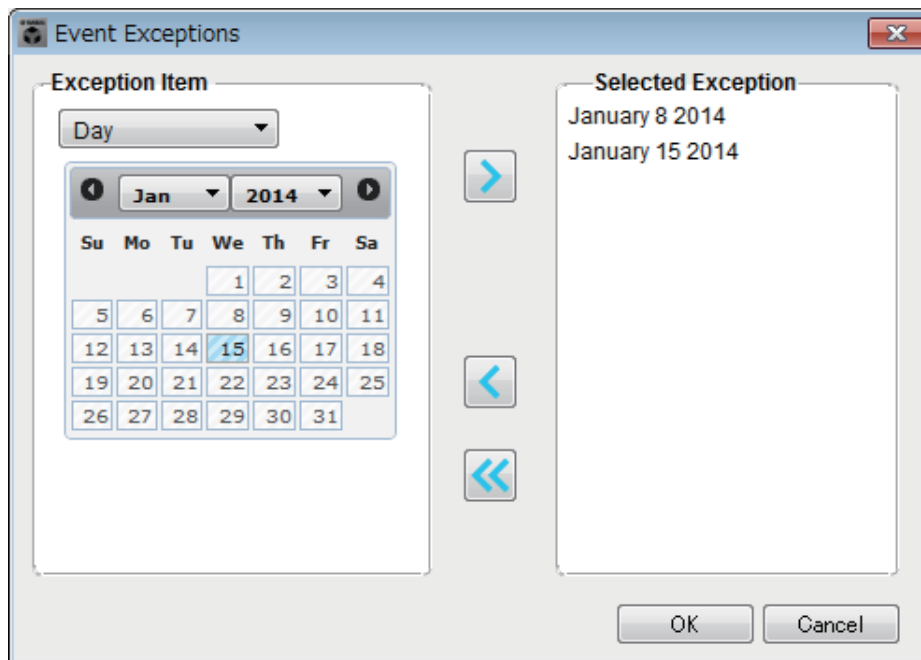

● **Exception Item**

**If the event frequency is [Yearly]**

Specify the year for which the event will not occur.

Only the [Year] can be specified.

**If the event frequency is [Monthly]**

Specify the month or day for which the event will not occur.

Only the [Month] and [Day] can be specified.

**If the event frequency is [Weekly]**

Specify the month, week, or day for which the event will not occur.

Only the [Month], [Week], and [Day] can be specified.

**If the event frequency is [Daily]**

Specify the month, week, day, or day of the week for which the event will not occur.

Only the [Month], [Week], [Day], and [Day of the week] can be specified.

**If the event frequency is [Hourly]**

Specify the month, week, day, day of the week, or time (in hours) for which the event will not occur.

The [Month], [Week], [Day], [Day of the week], and [Hour] can be specified.

● **[>] button**

Adds a date and time that you want to specify as an exception to the list at the right.

● **[<] button**

Removes a date and time that you specified as an exception from the list at the right.

● **[<<] button**

Removes all dates and times that you specified as exceptions from the list at the right.

● **[OK] button**

Saves the settings and closes the dialog box.

● **[Cancel] button**

Closes the dialog box without saving the changes.

■ **“SD Message Select” dialog box**

Here you can select the message file from the SD memory card that will be broadcast by the scheduler, and the Zone and Zone Group to which it will be broadcast.

If you want to use a Zone Group or a chime, make settings in the “PGM1/PGX1” dialog box.

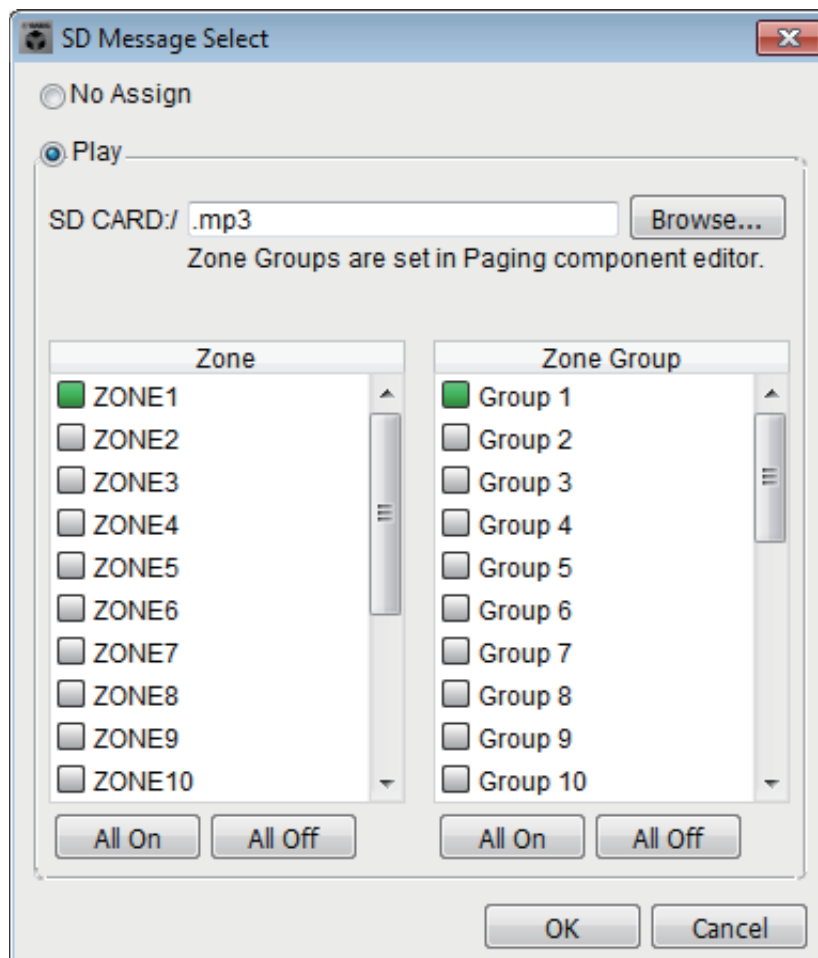

- **[No Assign] option button**  
If this is selected, no broadcast is made when the event occurs.
- **[Play] option button**  
If this is selected, a broadcast is made when the event occurs.
- **SD CARD:/**  
This indicates the selected message file.
- **[Browse] button**  
When you click this, a screen will appear, allowing you to select a message file.
- **[Zone]/[Zone Group]**  
These specify the Zone(s) and Zone Group(s) to which the broadcast is made. Click each square to turn it on (green) or off (white).
- **[All On]/[All Off] buttons**  
Clicking these buttons turns all Zones or Zone Groups on or off.
- **[OK] button**  
Click this to save the settings and close the dialog box.
- **[Cancel] button**  
Click this to close the dialog box without saving the settings.

## □ "Remote Control" dialog box

Here you can check the port numbers for connecting an external controller, or make settings for connecting an external controller to RS-232C.

- NOTE**
- A total of nine external controllers and wireless DCP units can be connected to a single MTX/MRX.
  - The IP address of the MTX/MRX can be viewed in the "Device Information" dialog box.

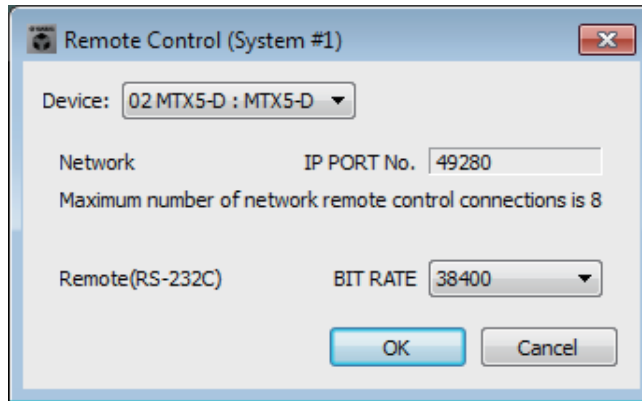

### ● [Device:] box

Select the MTX/MRX unit for which you want to make settings. The UNIT ID, device type, and device name are shown.

### ● [Network IP PORT No.]

This shows the port number of the MTX3's NETWORK connector or the MTX5-D/MRX7-D's Dante [PRIMARY]/[SECONDARY] connectors. You can connect up to eight external controllers or wireless DCP to the port.

### ● [Remote(RS-232C) BIT RATE] box

Selects the RS-232C communication speed. You can select "38400" bps or "115200" bps. You can connect one external controller to the RS-232C.

### ● [OK] button

Saves the settings and closes the dialog box.

### ● [Cancel] button

Closes the dialog box without saving the changes.

## □ “Digital Control Panel” dialog box

Here you can assign the MTX/MRX’s parameters to the controls of a digital control panel (DCP) such as the DCP1V4S so that they can be operated from the DCP. You can also make settings for the brightness of the DCP unit’s LEDs, as well as panel lock settings. You can’t make settings while online. (Settings can only be viewed.)

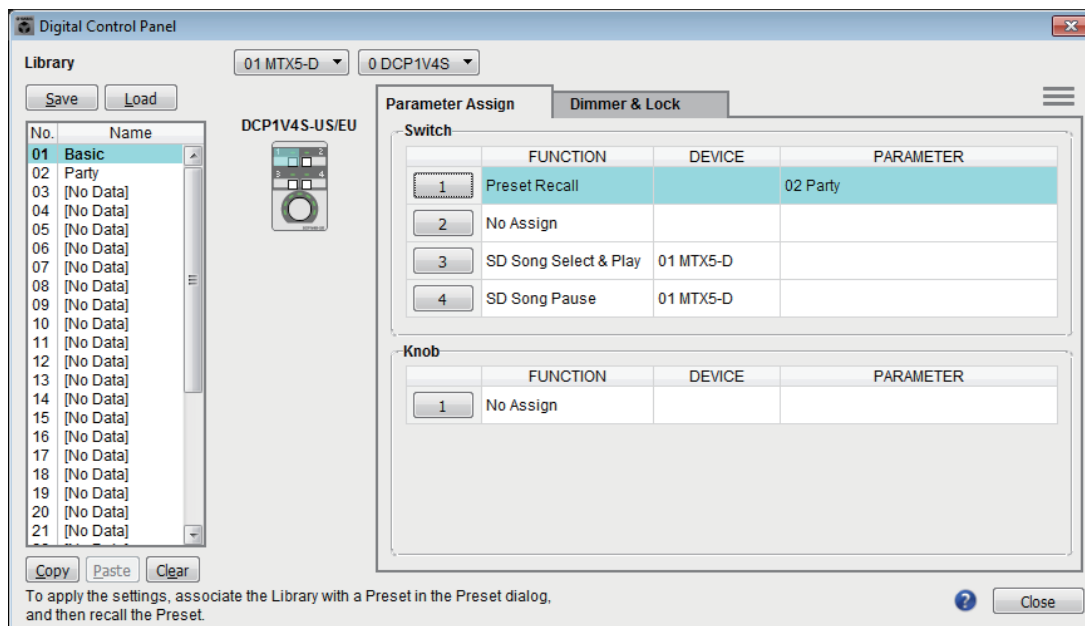

You can store 32 sets of DCP settings in the Library. You can also associate library items with presets for recall.

After editing in a tab such as [Parameter Assign]/[Dimmer & Lock]/[Source Select], click the item in the [Library] list to which you want to save, and then click the [Save] button to save the item to the library.

In the [Library] list, click the library item that you want to load, and then click the [Load] button to load the library item; the settings will be applied to tabs such as [Parameter Assign]/[Dimmer & Lock]/[Source Select].

- NOTE**
- If you associate a saved library item with a preset, the parameter assignments for all DCP units (up to 32 units) connected to the MTX/MRX system will be recalled/stored in a single action when you recall that preset. If you want to recall only a specific DCP, open the “Preset” dialog box and make [Recall Filter] settings.
  - You must use the “Device Configuration Wizard” dialog box to assign the MTX/MRX and DCP units and specify their ID settings beforehand. If you have not made these settings yet, you won’t be able to open the “Digital Control Panel” dialog box; an alert will be displayed.
  - The [Source Select] tab is shown if there is an MRX unit in the MTX/MRX system. For details, refer to “MRX Designer User Guide.”

### ● MTX/MRX selection box

Selects the MTX/MRX to which the target DCP unit is connected. The box will list units in order of UNIT ID, followed by the name of the MTX/MRX.

### ● DCP selection box

Select the DCP unit for which you want to make settings. All DCP units that are connected to the MTX/MRX (which is selected in the MTX/MRX selection box) are listed in order of UNIT ID and the name of the DCP unit.

The model and graphic for the selected DCP are shown below the DCP selection box. The control selected in the [Parameter Assign] tab will be highlighted.

### ● [Save] button

This button stores an item in the library. The "Save Library" dialog box will appear. If you edit the parameters of the loaded library item, the text will turn red. The text will turn black when you save or load the library item.

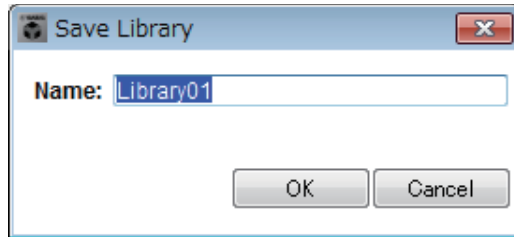

- **[Name:]**  
Enter a name for the library item.  
You can't enter the name of an existing library item, nor can you enter a blank name.
- **[OK] button**  
Saves the library item and closes the dialog box.
- **[Cancel] button**  
Closes the dialog box without creating a library item.

### ● [Recall] button

When you click this button, the currently selected library item will be recalled (loaded) as the current parameters.

### ● [Library] list

Select the library item that you want to save or load. The currently-loaded library item is shown in bold characters.

By double-clicking a previously-saved library item, you can edit its name.

- **[Copy] button**  
This button copies the selected library item.  
The Copy command is not available while online.
- **[Paste] button**  
This button pastes the copied library item to the library item that's currently selected in the list.  
The Paste command is not available while online.
- **[Clear] button**  
This button clears the contents of the library item that's currently selected in the list.  
The Clear command is not available while online.

● **[Parameter Assign] tab**

Here you can assign the MTX/MRX’s parameters to the various controls.

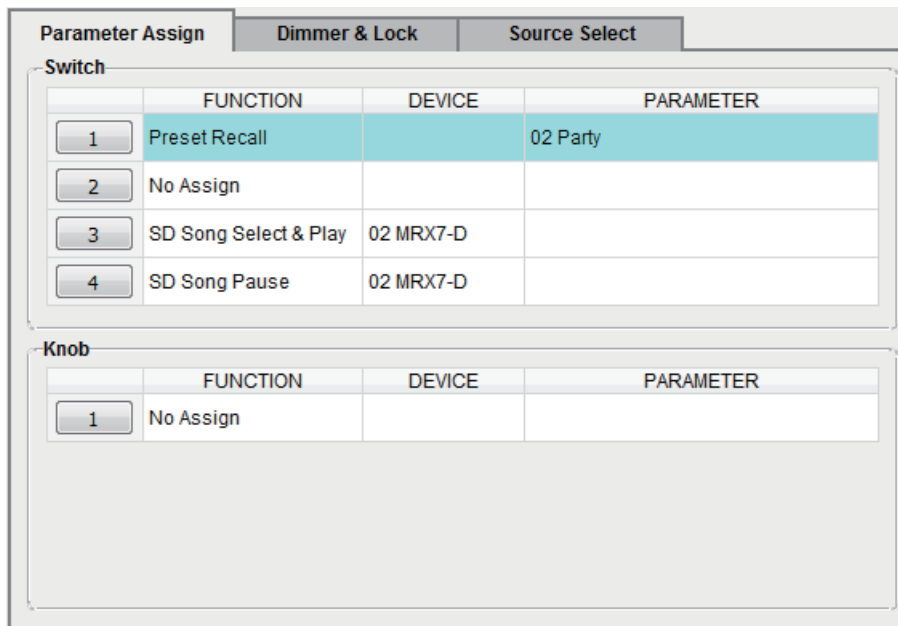

The currently-selected control is highlighted.

The corresponding control is also highlighted in the graphic that’s shown at the left of the tab.

○ **Control select buttons**

When you click a button, the “Settings” dialog box will appear, letting you make settings for the controls.

Specify the device or parameter that will be controlled by the control.

○ **[FUNCTION]/[DEVICE]/[PARAMETER]**

These show the items specified in the “Settings” dialog box.

● **[Dimmer & Lock] tab**

Here you can make settings for the brightness of the DCP unit’s LEDs, as well as settings for its inactive state.

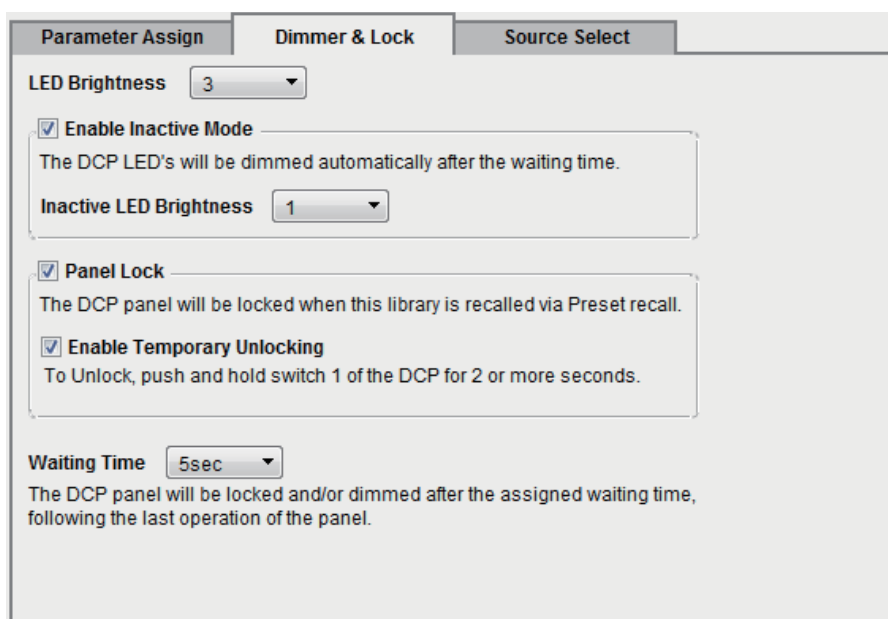

- **[LED Brightness] box**  
Specifies the brightness of the DCP unit's LEDs. Higher values will make the LEDs brighter.
- **[Enable Inactive Mode] check box**  
If the check box is selected, the unit automatically enters inactive mode after a time duration specified in [Waiting Time].  
[Inactive LED Brightness] specifies the brightness of the LEDs when inactive.  
If the check box is cleared, the drop-down menu is grayed-out and you will be unable to set the brightness.
- **[Panel Lock] check box**  
If this check box is selected, the DCP panel will be locked when the preset library is recalled.  
If the [Enable Temporary Unlocking] check box is selected, pressing and holding down DCP switch 1 for two seconds will unlock the panel.
- **[Waiting Time]**  
Specifies the time from the last operation until the unit enters inactive mode or the panel is locked.

● **Menu button (☰)**

Click this button to execute the following functions.

- **[Copy]**  
Copies the Parameter Assign, Dimmer & Lock, and Source Select of the displayed DCP to the copy buffer.
- **[Paste]**  
Overwrites the Parameter Assign, Dimmer & Lock, and Source Select settings of the same model from the copy buffer onto the displayed DCP.  
It is only possible to paste settings that were copied within the same MTX/MRX system.
- **[Initialize]**  
Initializes the Parameter Assign, Dimmer & Lock, and Source Select settings of the displayed DCP.
- **[Clear [Parameter Assign]]**  
Initializes the Parameter Assign settings of the displayed DCP.

● **[Close] button**

Closes the dialog box.

## “Settings” dialog box

You can access this dialog box from the “Digital Control Panel” dialog box, the “Wireless DCP” dialog box, or the “GPI” dialog box.

**NOTE** For details on the “Settings” dialog box that is accessed from the “Preset” dialog box and the “Scheduler” dialog box, refer to “Settings” dialog box in chapter 6.

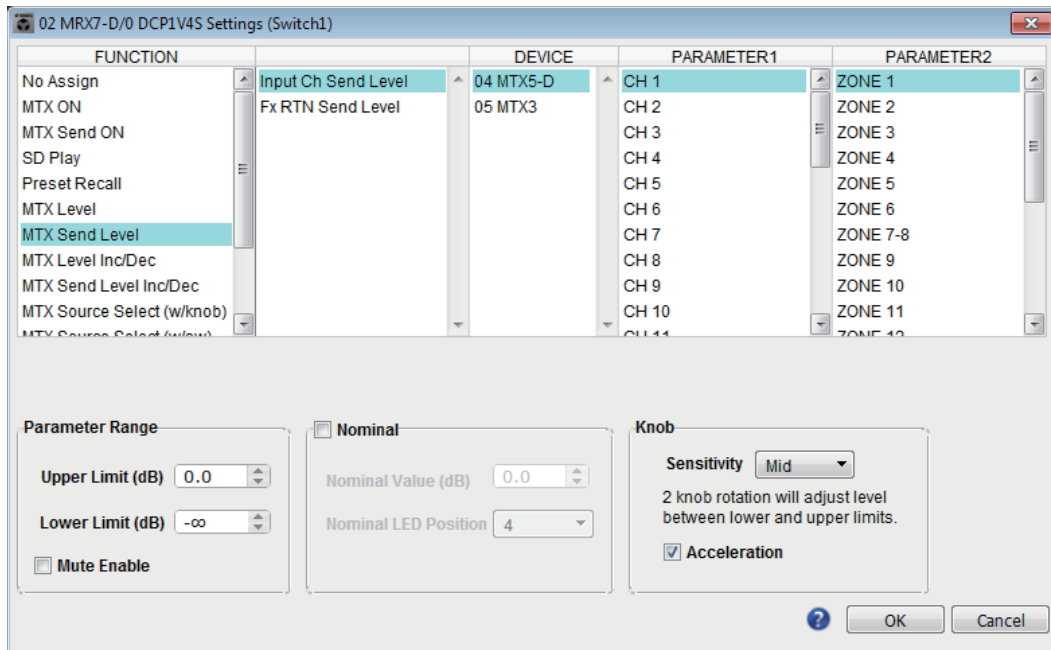

### ● [FUNCTION] list

Selects the function to be controlled. If you select [No Assign], no function will be assigned. The available range in [FUNCTION] and the contents of [DEVICE], [PARAMETER1], and [PARAMETER2] will depend on the function that you selected. The options shown in the lower half will also change.

For details on the functions and the display, refer to [List of settings in “Settings” dialog boxes](#).

### ● [DEVICE] list

Select the device that you want to change. These are shown in order of UNIT ID and model name.

### ● [PARAMETER1] list / [PARAMETER2] list

Specify the parameters of the function.

For details on these parameters, refer to [List of settings in “Settings” dialog boxes](#).

### ● [OK] button

Saves the settings and closes the dialog box.

### ● [Cancel] button

Closes the dialog box without saving the changes.

## □ “Wireless DCP” dialog box

Here you can assign the parameters of the MTX/MRX to controls of the “Wireless DCP” iOS app so that they can be operated from Wireless DCP. You can’t make settings while online. (Settings can only be viewed.)

For details on Wireless DCP, refer to the “Wireless DCP User’s Manual.”

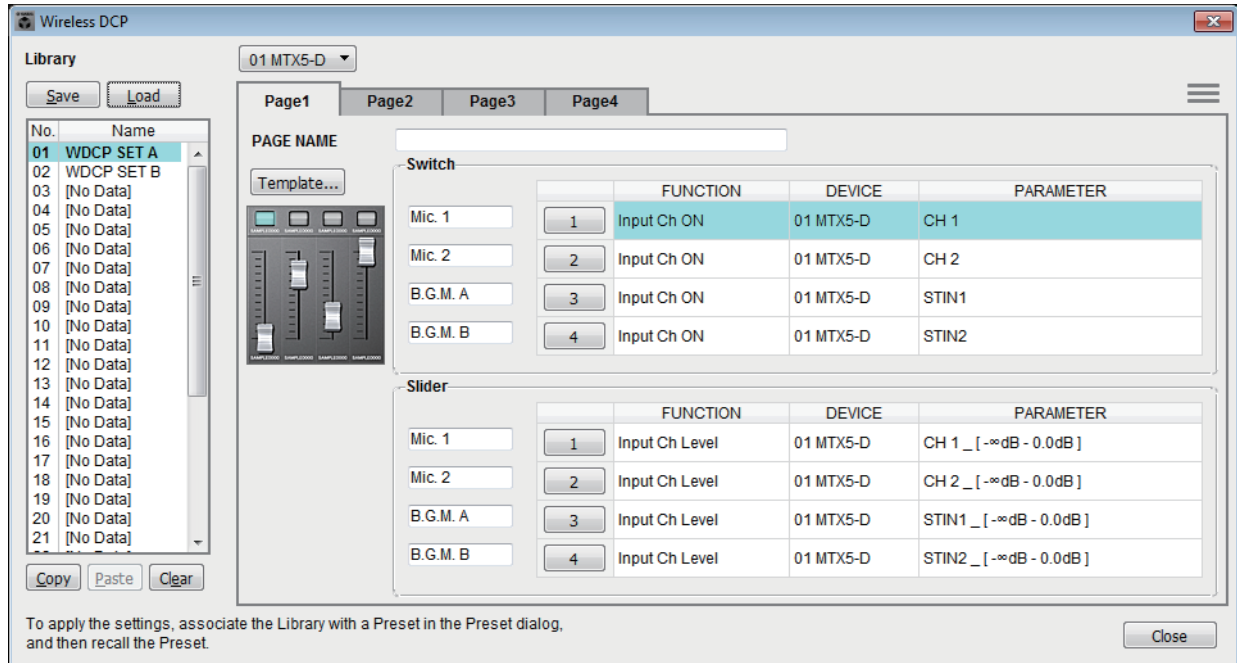

You can store 32 sets of Wireless DCP settings in the Library. You can also associate library items with presets for recall.

- NOTE**
- Associate the saved library item with a preset. If it is not associated, the Wireless DCP settings will not be applied.
  - The [Source Select] tab is shown if there is an MRX unit in the MTX/MRX system. For details, refer to “MRX Designer User Guide.”

For details on the following settings, refer to “Digital Control Panel” dialog box.

- [Save] button
- [Load] button
- [Library] list
- [Copy] button
- [Paste] button
- [Clear] button
- Control select buttons
- [FUNCTION]/[DEVICE]/[PARAMETER]
- “Settings” dialog box
- [Close] button

### ● MTX/MRX selection box

Here you can select the MTX/MRX to which the iPhone or other mobile device that you want to specify is connected. These are shown in order of UNIT ID and model name.

### ● [Page] tabs

Select the page tab that you want to edit.

● **Menu button (☰)**

Click this button to execute the following functions.

- **[Clear Page]**  
Initializes the displayed page.
- **[Clear All Pages]**  
Initializes the Wireless DCP settings of the selected MTX/MRX.

● **[PAGE NAME]**

Assign a name to the page. The name in the Wireless DCP “Page select” screen is shown.

● **[Template] button**

Click this to open the “Template” dialog box. Select the controls that will be shown in “Wireless DCP.”

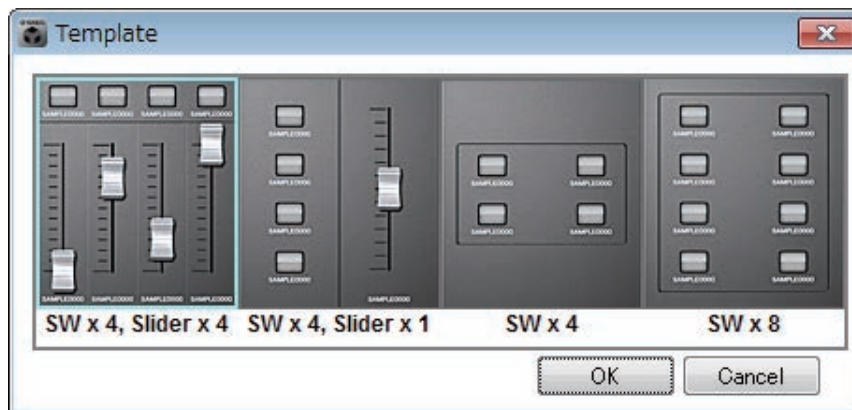

Click the template that you want to use.

- **[OK] button**  
Saves the selected template and closes the dialog box.
- **[Cancel] button**  
Cancels the template selection and closes the dialog box.

● **Control label**

Assign a name to the control.

## □ “MCP1” dialog box

Up to 16 MCP1 units can be connected to one MTX/MRX system.

Using Ethernet cables, connect the MTX/MRX unit’s [NETWORK] port or Dante port to a PoE network switch, and connect the PoE network switch to the MCP1.

If the network switch does not support PoE, connect a PoE injector between the network switch and the MCP1.

Some PSE units (PoE network switches or PoE injectors) might have some ports that supply power and other ports that do not supply power. Connect the MCP1 to a port that supplies power.

In this dialog box you can make settings for the MCP1’s L1/2/3 and R1/2/3 switches and display.

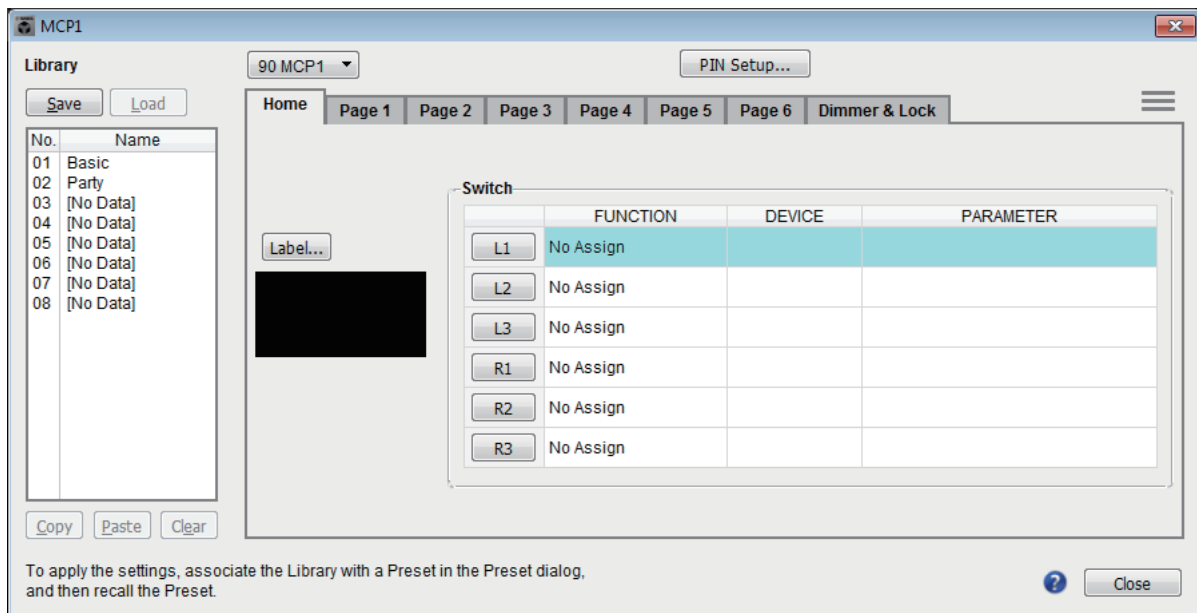

You can store 8 sets of MCP1 settings in the Library. You can also associate library items with presets for recall.

After editing in a tab such as [Home]/[Page 1]–[Page 6]/[Dimmer & Lock]/[Source Select], click the item in the [Library] list to which you want to save, and then click the [Save] button to save the item to the library.

In the [Library] list, click the library item that you want to load, and then click the [Load] button to load the library item; the settings will be applied to tabs such as [Home]/[Page 1]–[Page 6]/[Dimmer & Lock]/[Source Select].

- NOTE**
- If you associate a saved library item with a preset, the parameter assignments of [HOME] and [Page 1] through [Page 6] for all MCP1 units (up to 16 units) connected to the MTX/MRX system will be recalled/stored in a single action when you recall that preset. If you want to recall only a specific MCP1 unit, open the “Preset” dialog box and make [Recall Filter] settings.
  - You must use the “Device Configuration Wizard” dialog box to assign the MTX/MRX and MCP1 units and specify their ID settings beforehand. If you have not made these settings yet, you won’t be able to open the “MCP1” dialog box; an alert will be displayed.
  - The [Source Select] tab is shown if there is an MRX unit in the MTX/MRX system. For details, refer to “MRX Designer User Guide.”

### ● MCP1 select list box

Select the MCP1 unit for which you want to make settings. All MCP1 units that are connected to the MTX/MRX system are listed in order of UNIT ID and the name of the MCP1 unit.

### ● [PIN Setup] button

This button shows the “PIN Setup” dialog box where you can specify three types of PIN.

**● [Save] button**

This button saves an item in the library. The "Save Library" dialog box will appear. If you edit the parameters of the loaded library item, the text will turn red. The text will turn black when you save or load the library item.

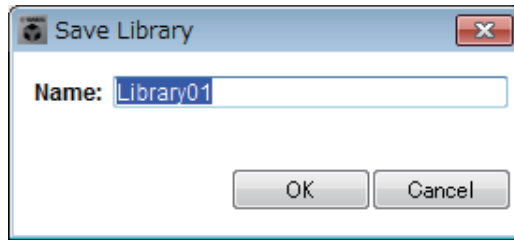

- **[Name:]**  
Enter a name for the library item.  
You can't enter the name of an existing library item, nor can you enter a blank name.
- **[OK] button**  
Saves the library item and closes the dialog box.
- **[Cancel] button**  
Closes the dialog box without creating a library item.

**● [Load] button**

When you click this button, the currently selected library item will be loaded as the current parameters.

**● [Library] list**

Select the library item that you want to save or load. The currently-loaded library item is shown in bold characters.

By double-clicking a previously-saved library item, you can edit its name.

- **[Copy] button**  
This button copies the selected library item.  
The Copy command is not available while online.
- **[Paste] button**  
This button pastes the copied library item to the library item that's currently selected in the list.  
The Paste command is not available while online.
- **[Clear] button**  
This button clears the contents of the library item that's currently selected in the list.  
The Clear command is not available while online.

● **[Home]/[Page 1]–[Page 6] tabs**

Here you can make settings related to the MCP1 page. The home page is the page that appears at start-up, or when you touch the MCP1’s home switch.

In the home page, you can switch pages by assigning [Open Page] to a switch. Here we explain using the [Page 1] tab.

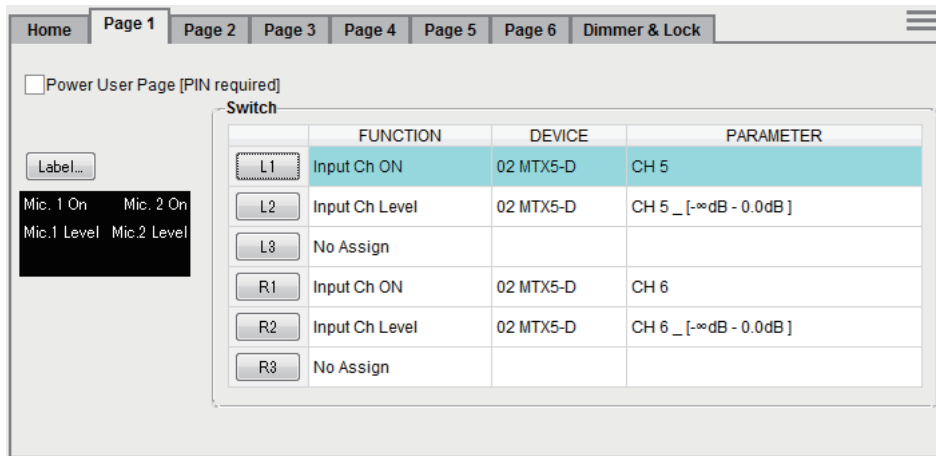

The currently-selected switch is highlighted.

- **[Power User Page [PIN required]] check box (other than the [Home] page)**  
If this check box is selected, the PIN code specified in the [Power User PIN:] field of the “PIN Setup” dialog box must be entered on the MCP1 when the page is opened.
- **[Label] button**  
When you click this button, the “Label” dialog box appears, allowing you to create an image for the display. The currently specified image is shown below the button.
- **Switch select buttons**  
When you click a button, the “Settings” dialog box will appear, letting you make settings for each switch.  
Specify the device or parameter that will be controlled by the switch.
- **[FUNCTION]/[DEVICE]/[PARAMETER]**  
These show the items specified in the “Settings” dialog box.

## ● [Dimmer & Lock] tab

Here you can make settings for the brightness of the MCP1's display and switches, and for panel lock.

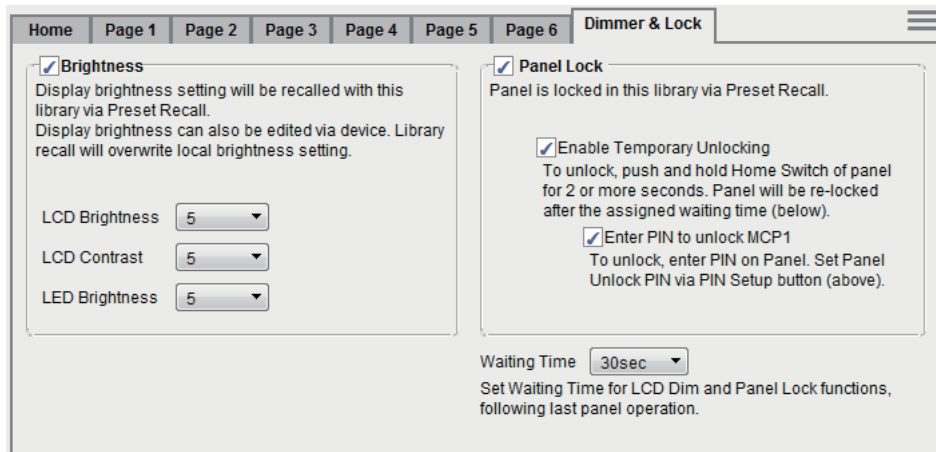

### • [Brightness] check box

If this check box is selected, the brightness and contrast of the display, and the brightness of the switches, can be changed when a preset recalls the currently-edited library item.

[LCD Brightness] specifies the brightness of the display. Higher values will make the display brighter.

[LCD Contrast] specifies the display's contrast. Higher values produce a greater difference between light and dark.

[LED Brightness] specifies the brightness of the switches. Higher values will make the switches brighter.

If the check box is cleared, the drop-down menu is grayed out and you will be unable to set the brightness.

### • [Panel Lock] check box

If this check box is selected, the MCP1 panel will be locked when the library item is recalled by a preset.

If the [Enable Temporary Unlocking] check box is selected, pressing and holding down the MCP1's home switch for two seconds or longer will unlock the panel.

If the [Enter PIN to unlock MCP1] check box is selected, pressing and holding down the MCP1's home switch for two seconds or longer will then require the PIN code specified in [Panel Unlock PIN:] of the "PIN CODE" dialog box to be entered on the MCP1.

### • [Waiting Time]

Specifies the time from the last operation until the unit enters inactive mode or the panel is locked.

**● Menu button (☰)**

Click this button to execute the following functions.

- **[Copy]**  
Copies the Home, Page 1–Page 6, Dimmer & Lock, and Source Select settings of the displayed MCP1 to the copy buffer.
- **[Paste]**  
Overwrites the Home, Page 1–Page 6, Dimmer & Lock, and Source Select settings from the copy buffer onto the displayed MCP1.  
It is only possible to paste settings that were copied within the same MTX/MRX system.
- **[Initialize]**  
Initializes the Home, Page 1–Page 6, Dimmer & Lock, and Source Select settings of the displayed MCP1.
- **[Clear Page]**  
Initializes the Home or Page 1–Page 6 settings that are displayed.
- **[Clear All Page]**  
Initializes all of the Home and Page 1–Page 6 settings of the displayed MCP1.

**● ? button**

Click this to view help for MCP1 settings.

**● [Close] button**

Closes the dialog box.

## □ “PIN Setup” dialog box

Here you can specify PIN codes for all MCP1 units within the MTX/MRX system.

A PIN code is specified if the system goes online with the MCP1 even once. If this has not been specified, use 1111 to unlock.

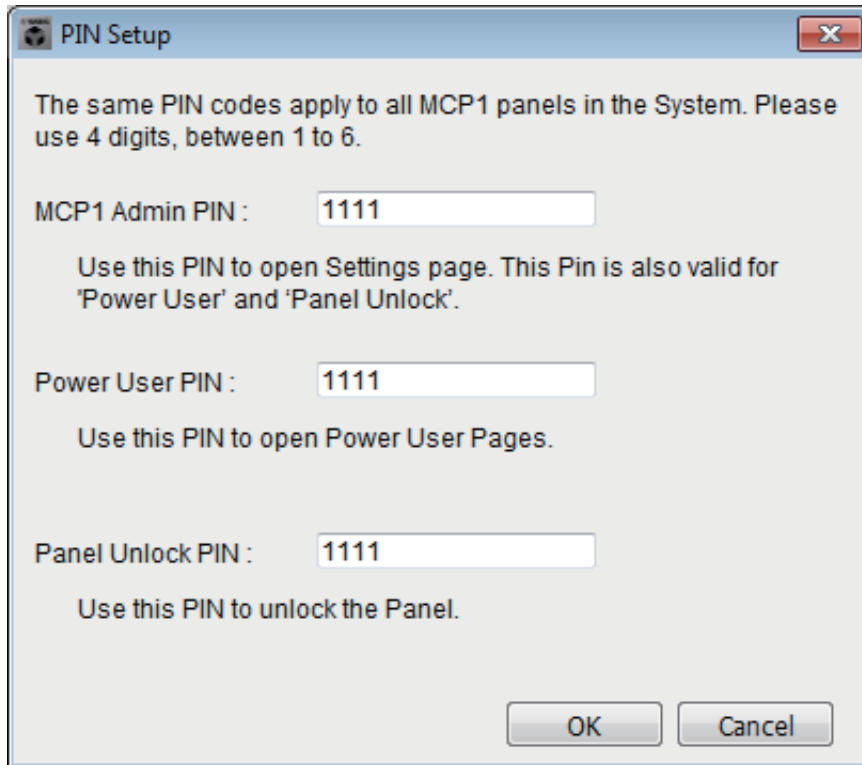

- **[MCP1 Admin PIN:] text box**

This is the PIN code for opening the MCP1’s Settings page.

It can also be used as the “Power User PIN” or the “Panel Unlock PIN.”

- **[Power User PIN:] text box**

This is the PIN code for opening pages for which the [Power User Page [PIN required]] check box is selected in a [Page 1]–[Page 6] tab of the “MCP1” dialog box.

- **[Panel Unlock PIN:] text box**

This is the PIN code for defeating panel lock if the [Enter PIN to unlock MCP1] check box is selected in the [Dimmer & Lock] tab of the “MCP1” dialog box.

## □ “Label” dialog box

Here you can create a page image to show in the MCP1’s display.

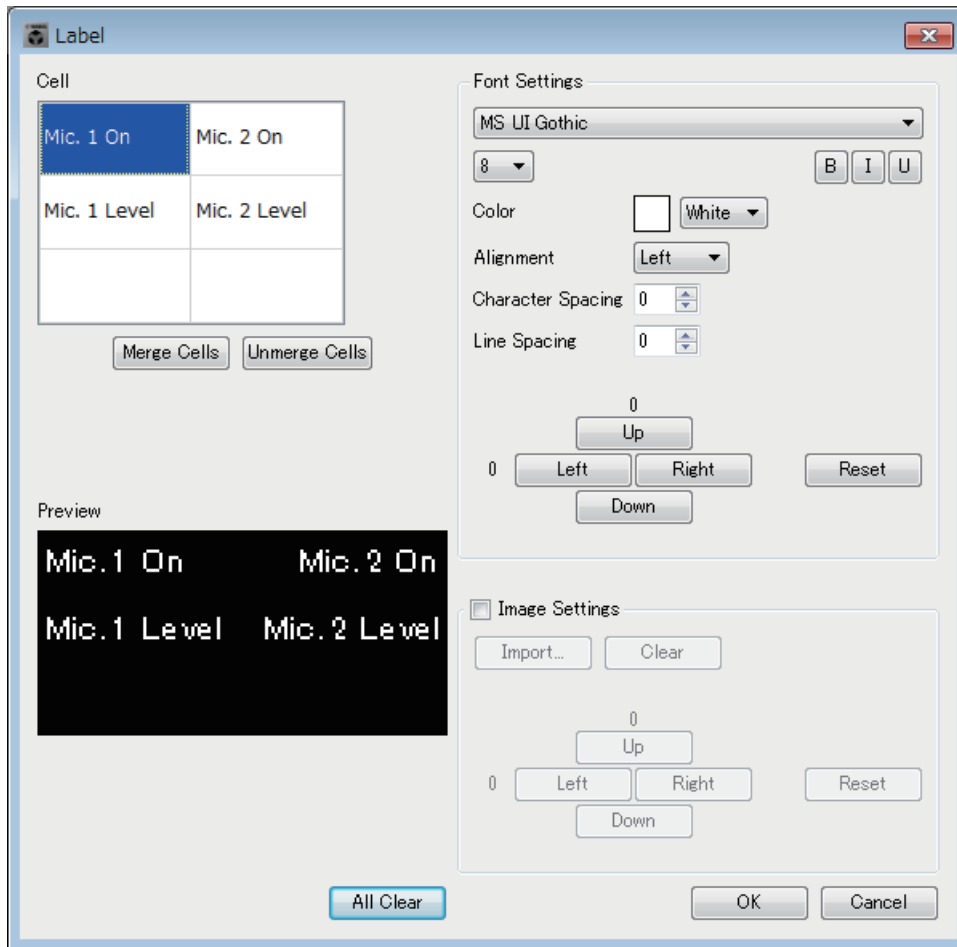

- **[Cell]**

Edit the page image.

To edit the text string, select a cell and double-click or press the <F2> key. To confirm, press the <Enter> key or use the mouse to select another cell.

To insert an image, select the cell, then select the [Image Settings] check box and press the [Import] button and select an image file.

To move between cells, you can use not only mouse operations but also the cursor keys, <Tab> key, or <Enter> key. By holding down the <Shift> key while moving between cells, you can select a region.

- **[Merge Cells] button**

Select multiple cells and click this button to merge the cells.

- **[Unmerge Cells] button**

Select a merged cell and click this button to unmerge the cells.

- **“Font Settings” area**

Here you can specify the font for the selected cell. The “Preview” area shows how the settings will appear.

- **Font list box**

Selects a font for the text string. You can choose from the fonts that are installed in the computer.

- **Font size list box**  
Selects the font size for the text string.
- **[B]/[I]/[U] buttons**  
Click these buttons to apply bold, italic, or underlined character styles to the text string in the cell.
- **"Color"**  
Indicates the color of the text string in the cell. Click this button to switch between white and black.
- **[Alignment] list box**  
Selects the position at which the text string is displayed in the cell.
- **[Character Spacing] spin buttons**  
Specify the spacing of the characters in the cell.
- **[Line Spacing] spin buttons**  
Specify the spacing of the lines in the cell.
- **[Up]/[Left]/[Right]/[Down]/[Reset] buttons**  
Adjusts the position of the characters in the cell. The amount of movement is shown numerically. Click the [Reset] button to restore the initial settings.
- **"Image Settings"**  
If this check box is selected, you can make settings regarding a background image for the selected cell.
  - **[Import] button**  
Click this to open the "Open File" dialog box. Select image data, and then click the [OK] button to open the "Re-size Image" dialog box, where you can choose how the image is placed in the cell. You can select images that have a file extension of \*.png, \*.bmp, or \*.jpg.
  - **[Clear] button**  
Click this to delete the background image.
  - **[Up]/[Left]/[Right]/[Down]/[Reset] buttons**  
Adjust the position of the background image in the cell. The amount of movement is shown numerically. Click the [Reset] button to restore the initial settings.
- **"Preview"**  
Shows the page image.
- **[All Clear] button**  
Initializes all settings of the cell.
- **[OK] button**  
Saves the settings and closes the dialog box.
- **[Cancel] button**  
Discards the settings and closes the dialog box.

## □ "Re-size Image" dialog box

Here you can select how the image is placed.

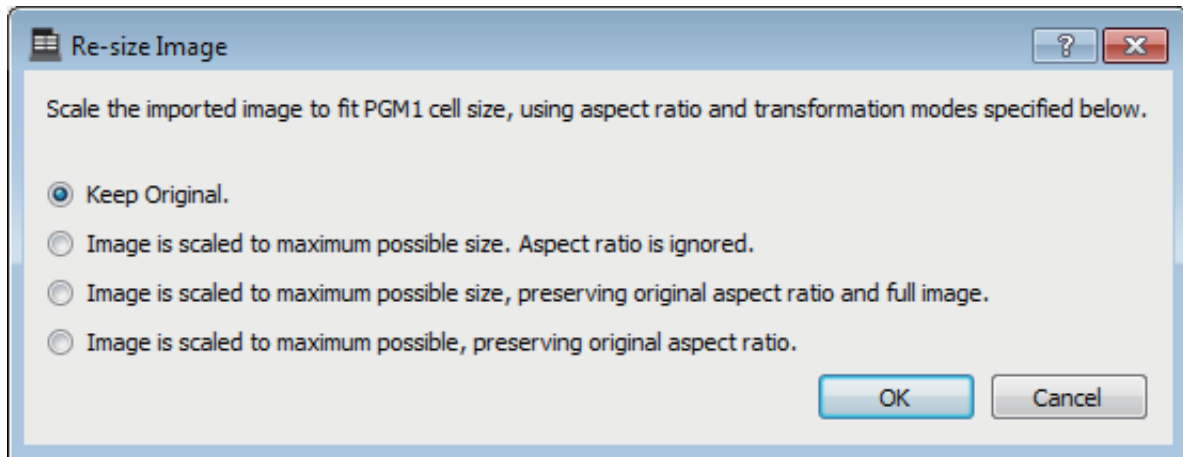

### ● Option buttons

From above, the following choices are provided.

- Keep Original
- Image is scaled to maximum possible size. Aspect ratio is ignore.
- Image is scaled to maximum possible size, preserving original aspect ratio and full image.
- Image is scaled to maximum possible, preserving original aspect ratio.

### ● [OK] button

Assigns the image to the cell and closes the dialog box.

### ● [Cancel] button

Closes the dialog box without assigning the image to the cell.

## □ “PGM1/PGX1” dialog box

Here you can make assignments for the zone/message select buttons of the PGM1 and PGX1, and make settings for the PTT button.

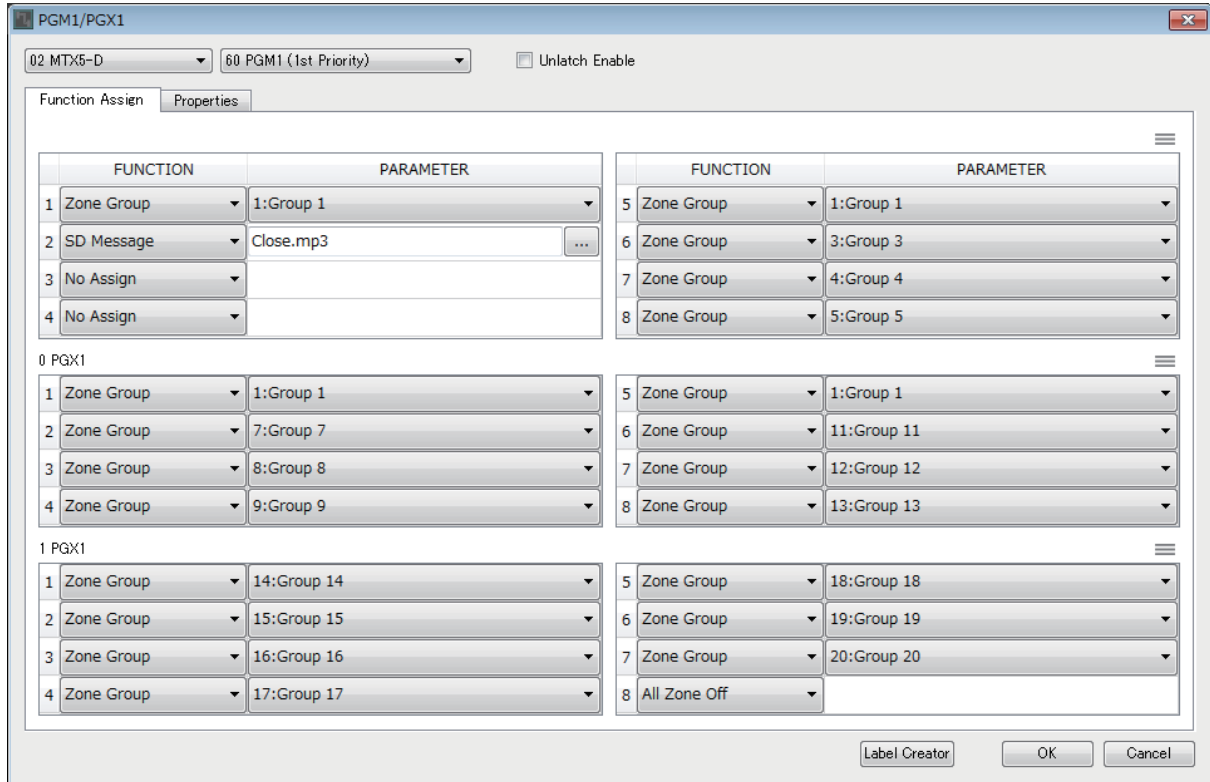

- **MTX/MRX select list box**

Selects the MTX/MRX to which the PGM1 unit for which you want to make settings is connected. The list box shows units in order of UNIT ID and the name of the MTX/MRX.

- **PGM1 select list box**

Select the PGM1 unit for which you want to make settings. All PGM1 units that are connected to the MTX/MRX selected in the MTX/MRX selection box are listed in order of UNIT ID and the name of the PGM1 unit.

- **[Unlatch Enable] check box**

If this check box is selected, the PTT button of the selected PGM1 operates both as latched and unlatched. If this check box is not selected, the PTT button operates as latched.

● **[Function Assign] tab**

Here you can assign functions to the zone/message select buttons of the PGM1 or PGX1.

	FUNCTION	PARAMETER		FUNCTION	PARAMETER
1	Zone Group	1:Group 1	5	Zone Group	1:Group 1
2	SD Message	Close.mp3	6	Zone Group	3:Group 3
3	No Assign		7	Zone Group	4:Group 4
4	No Assign		8	Zone Group	5:Group 5

0 PGX1					
	FUNCTION	PARAMETER		FUNCTION	PARAMETER
1	Zone Group	1:Group 1	5	Zone Group	1:Group 1
2	Zone Group	7:Group 7	6	Zone Group	11:Group 11
3	Zone Group	8:Group 8	7	Zone Group	12:Group 12
4	Zone Group	9:Group 9	8	Zone Group	13:Group 13

1 PGX1					
	FUNCTION	PARAMETER		FUNCTION	PARAMETER
1	Zone Group	14:Group 14	5	Zone Group	18:Group 18
2	Zone Group	15:Group 15	6	Zone Group	19:Group 19
3	Zone Group	16:Group 16	7	Zone Group	20:Group 20
4	Zone Group	17:Group 17	8	All Zone Off	

“FUNCTION” provides the following choices.

- **[No Assign]**  
No function is assigned to the button.
- **[Zone]**  
A zone list box is shown in “PARAMETER.” Select the zone to which to broadcast.
- **[Zone Group]**  
A zone group list box is shown in “PARAMETER.” Select the zone group to which to broadcast. Make zone group assignments in “PAGING” of the “ZONE” screen.
- **[SD Message]**  
A button is shown in “PARAMETER.” Specify the message file that will be played.
- **[All Zone Off]**  
Clears the entire set of PGM1/PGX1 zone or zone group selections.
- **Menu button (☰)**  
Click the menu button to execute the following functions.
  - **[Copy]**  
Copies the FUNCTION and PARAMETER settings of the corresponding device to the copy buffer.
  - **[Paste]**  
Pastes the FUNCTION and PARAMETER settings from the copy buffer, overwriting them onto the corresponding device.
  - **[Clear]**  
Initializes the FUNCTION and PARAMETER settings of the corresponding device.

● **[Properties] tab**

Here you can make settings for the operation of the PCM1.

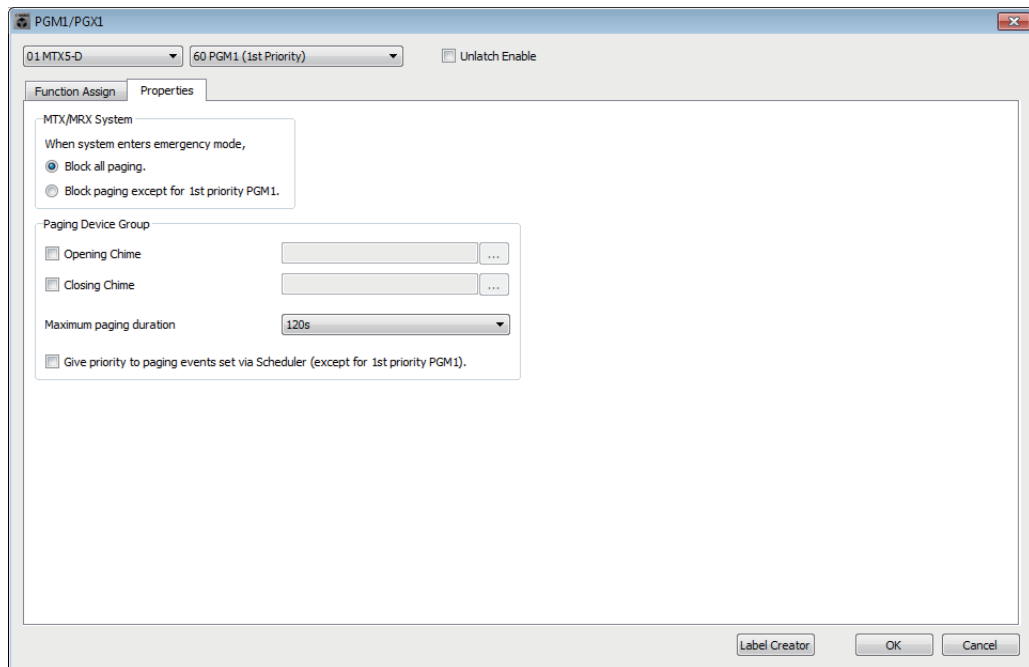

- **[Stop all broadcast.] option button**  
If this is selected, paging broadcast including the scheduler will be stopped when the MTX/MRX system is in emergency mode.
- **[Stop broadcast except for 1st Priority PGM1] option button**  
If this is selected, paging broadcast will be possible only for the 1st Priority PGM1 when the MTX/MRX system is in emergency mode.
- **[Opening Chime]/[Closing Chime] check boxes**  
If these check boxes are selected, you can make settings for the opening chime and/or closing chime. Click the button at right to specify the chime file that will play. This setting is shared by the PGM1 (Paging Device Group) units that are connected to the same MTX/MRX.
- **[Maximum paging duration] list box**  
Selects the time after PTT is turned on until it is automatically turned off. If a message is being played back, it will not turn off even if the specified time is exceeded. This setting is shared by the PGM1 units that are connected to the same MTX/MRX.
- **[The scheduler’s paging events are broadcast with higher priority than PGM1. Paging events have a lower priority than 1st Priority PGM1.] check box**  
If this check box is selected, the priority order will be “1st Priority PGM1 > events > normal PGM1.” If this check box is cleared, the priority order will be “1st Priority PGM1 > normal PGM1 > events.”
- **[Label Creator] button**  
Click this button to start the “PGM1 Label Creator” application.
- **[OK] button**  
Saves the settings and closes the dialog box.
- **[Cancel] button**  
Discards the settings and closes the dialog box.

## □ “PGM1 Label Creator” application

Here you can create a printable label image for the PGM1 or PGX1.  
To print the label, connect a printer to the computer.

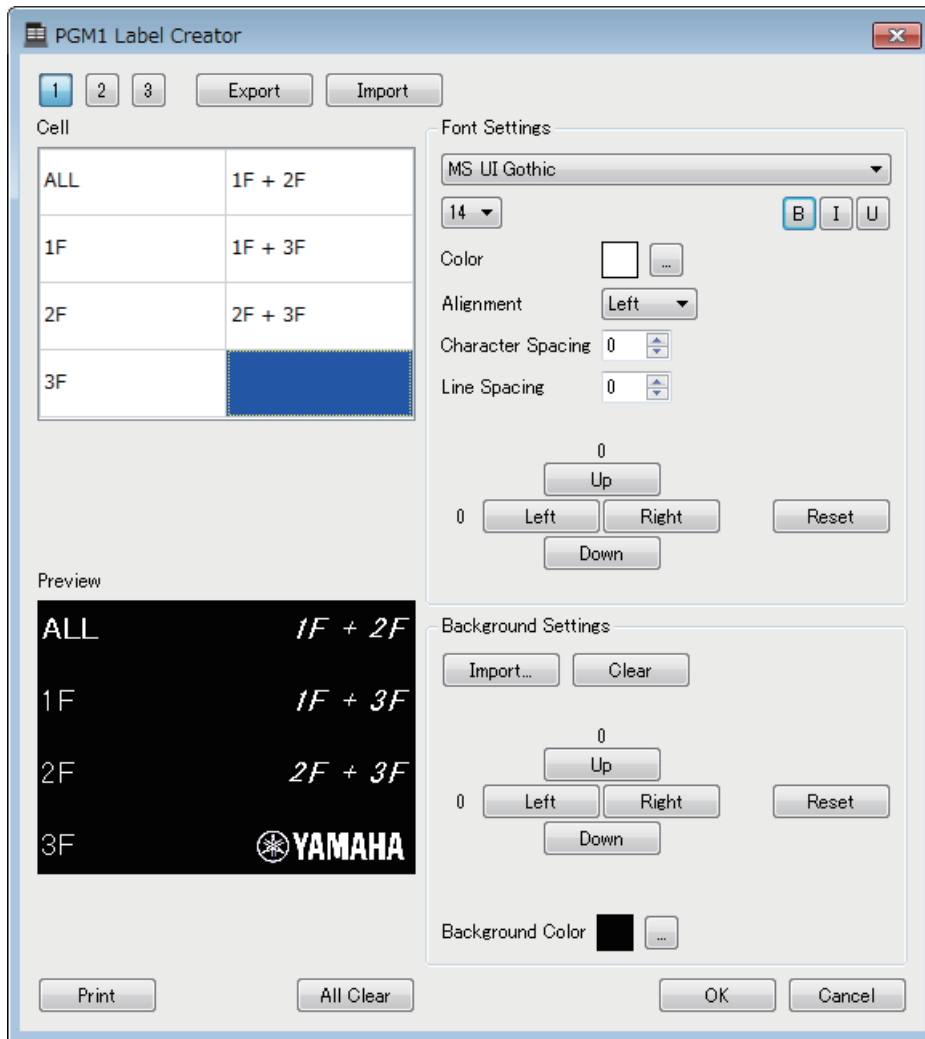

- **Pattern select buttons**

Select the label pattern. PGM1 Label Creator can store up to three patterns on one computer.

- **[Export] button**

Saves the settings to a file. Click this to open the “Save File” dialog box. The file extension is \*.plc.

- **[Import] button**

Loads settings from a \*.plc file. Click this to open the “Load File” dialog box.

- **[Cell]**

Here you can edit the label.

To edit the text string, select a cell and double-click or press the <F2> key. To confirm, press the <Enter> key or use the mouse to select another cell.

To insert an image, select the cell, then press the [Import] button in the “Background Settings” area, and select an image file.

To move between cells, you can use not only mouse operations but also the cursor keys, <Tab> key, or <Enter> key. By holding down the <Shift> key while moving between cells, you can select a region.

### ● "Font Settings" area

Here you can specify the font for the selected cell. The "Preview" area shows how the settings will appear.

- **Font list box**  
Selects a font for the text string. You can choose from the fonts that are installed in the computer.
- **Font size list box**  
Selects the font size for the text string.
- **[B]/[I]/[U] buttons**  
Click these buttons to apply bold, italic, or underlined character styles to the text string in the cell.
- **"Color"**  
Indicates the color of the text string in the cell. When you click this button, the "Select Color" dialog box will appear, allowing you to select a color.
- **[Alignment] list box**  
Selects the position at which the text string is displayed in the cell.
- **[Character Spacing] spin buttons**  
Specify the spacing of the characters in the cell.
- **[Line Spacing] spin buttons**  
Specify the spacing of the lines in the cell.
- **[Up]/[Left]/[Right]/[Down]/[Reset] buttons**  
Adjusts the position of the characters in the cell. The amount of movement is shown numerically. Click the [Reset] button to restore the initial settings.

### ● "Background Settings"

Here you can specify settings for the background image of the selected cell.

- **[Import] button**  
Click this to open the "Open File" dialog box. Select image data, and then click the [OK] button to open the "Re-size Image" dialog box, where you can choose how the image is placed in the cell. You can select images that have a file extension of \*.png, \*.bmp, or \*.jpg.
- **[Clear] button**  
Click this to delete the background image.
- **[Up]/[Left]/[Right]/[Down]/[Reset] buttons**  
Adjust the position of the background image in the cell. The amount of movement is shown numerically. Click the [Reset] button to restore the initial settings.
- **"Background Color"**  
Indicates the background color of the cell. When you click this button, the "Select Color" dialog box will appear, allowing you to select a color.

### ● "Preview"

Shows the print image.

### ● [Print] button

Click this to open the Print dialog box.

- **[All Clear] button**  
Initializes all cell settings for the selected pattern.
- **[OK] button**  
Saves the settings and closes the application. Since the settings are not saved in the MTX-MRX Editor project file, you should click the [Export] button and save the file if you want to reuse the settings.
- **[Cancel] button**  
Discards the settings and closes the application.

## □ "GPI" dialog box

GPI stands for General Purpose Interface. By using the GPI input/output, you can remotely control the MTX/MRX via custom-made controllers or external devices. A controller that is connected to the GPI input connector can be used to switch presets on the MTX/MRX or to control the parameters of components. GPI input/output settings are made individually for each device.

Display devices such as LEDs and lamps or external control equipment made by other manufacturers can be connected to the GPI output connector, letting you control the external device according to the state of presets or parameters.

For hardware-related details such as how to connect the [GPI] connector, refer to the owner's guide of each unit.

### <Usage example 1>

#### Using a home-made switch panel to switch presets

Connect a momentary switch to each of the MTX/MRX's [GPI IN-1] through [GPI IN-3] connectors, and make settings so that they will recall Preset1-3.

### <Usage example 2>

#### Controlling the volume of the MTX/MRX

Connect a variable resistor to one of the MTX/MRX's [GPI IN] connectors, and assign Output Ch Level to the GPI Input Port so that the volume will be controlled.

### <Usage example 3>

#### Controlling the volume of multiple MTX/MRX units

Connect a variable resistor to one of the MTX/MRX's [GPI IN] connectors, and assign ZONE Out DCA Group to the GPI Input Port so that the zone volume of multiple MTXMRX units will be controlled in tandem.

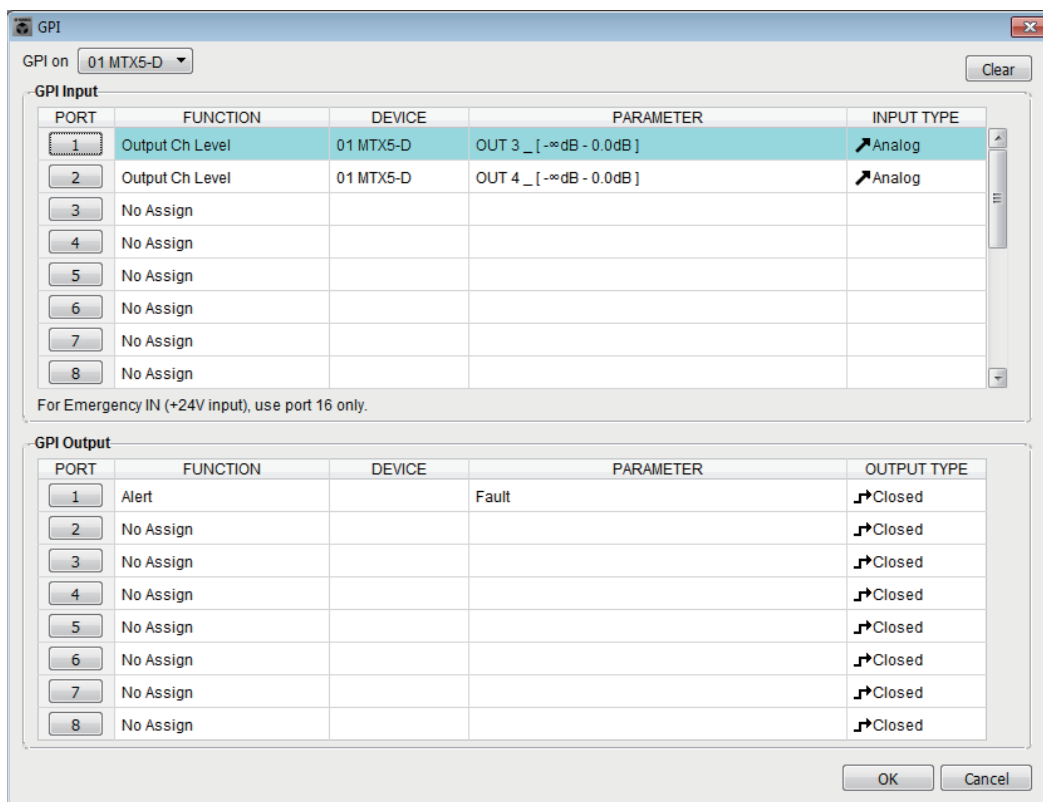

This dialog box can be edited only while offline.

- **[GPI on] box**

From the list, choose the MTX/MRX unit whose settings you want to specify. The list shows the UNIT ID and device name of the MTX/MRX units that are assigned to the MTX/MRX system.

- **[Clear] button**

Initializes the settings of all ports.

- **PORT select buttons**

These buttons open the "Settings" dialog box where you can make settings for each port.

For details on these parameters, refer to [List of settings in "Settings" dialog boxes](#).

- **[OK] button**

Saves the settings and closes the dialog box.

- **[Cancel] button**

Closes the dialog box without saving the changes.

## □ “GPI Calibration” dialog box

Here you can calibrate the input voltage detection range for the [GPI] connector of the MTX/MRX unit. (Available only when online.) These settings adjust the detection range in order to stabilize the input voltage of the [GPI] connector.

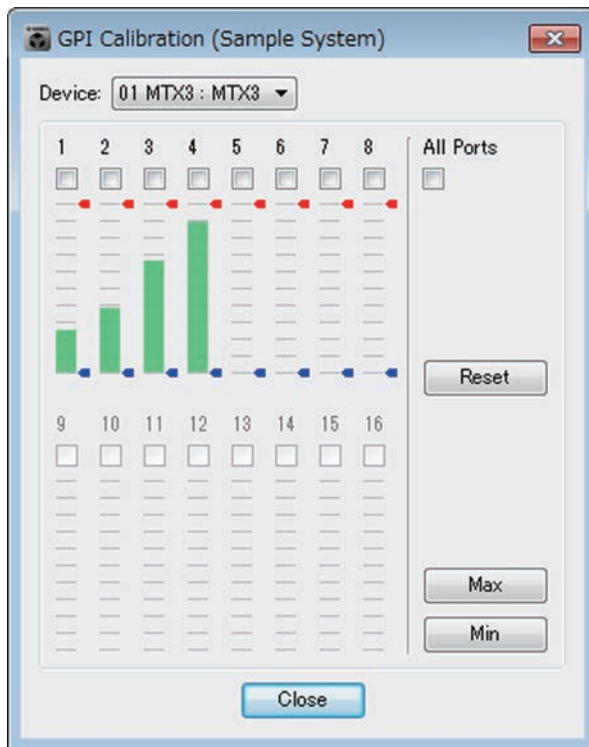

- **[Device:] box**

Selects an MTX/MRX unit within the MTX/MRX system.

From the left, this shows the “UNIT ID,” “Type (model name of the device),” and “Device Name (name of the device).”

- **Channel select check boxes**

Calibration will be applied to the channels whose boxes are selected.

- **[All Ports] check box**

Selects the check boxes of all channels.

- **Calibration data**

The input voltage is shown in real time as a graph.

- **[Reset] button**

Calibration will be reset for the channels whose boxes are selected.

- **[Max] button**

Sets the current input voltage of the selected channels to the maximum value. The maximum value you set is shown by a red bar.

- **[Min] button**

Sets the current input voltage of the selected channels to the minimum value. The minimum value you set is shown by a blue bar.

- **[Close] button**

Closes the dialog box.

### Calibration procedure

- 1. Connect your external device to the MTX/MRX's [GPI] connector.**
- 2. Select the check box of the channel numbers for which you want to perform calibration.**

If you want to select all channels, select the [All Ports] check box.

- 3. To specify the detection range, increase the input from the external device to the maximum and click the [Max] button; then decrease the input to the minimum and click the [Min] button.**

This lets you specify the optimal detection range as appropriate for voltage drop caused by wiring or due to the specifications of your devices.

- NOTE**
- *The threshold for on/off switching will be the center value between the maximum and minimum input voltage values (the sum of the maximum value and minimum value, divided by 2). To prevent malfunctions, you should allow plenty of range for detection.*
  - *If the voltage has dropped because of cable length or noise, adjust the maximum and minimum input voltage values. Since voltage may become unstable, configure and set up your external circuit to ensure that there is ample distance between the maximum and minimum values.*

## □ “Security Settings” dialog box

On the MTX/MRX system, you can specify a PIN code (numeric password) for security.

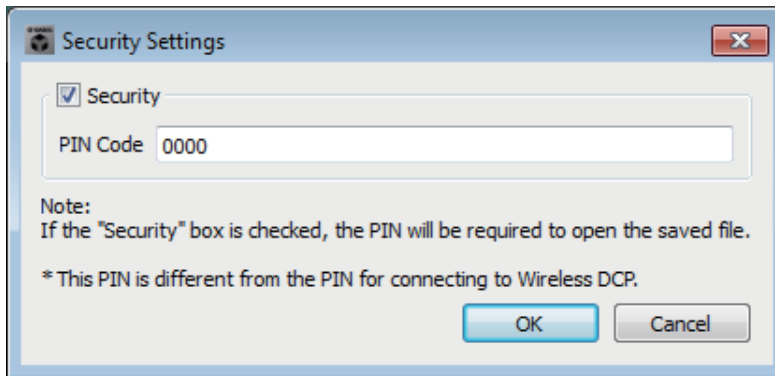

### ● [Security] check box

If this check box is selected, the “Security” dialog box will appear when the project file starts.

If this check box is cleared, all users will be able to make changes in MTX-MRX Editor.

### ● [PIN Code]

If the [Security] check box is selected, enter the PIN code (four single-byte numerals). You cannot enter anything other than single-byte numerals, nor can you enter a blank PIN code.

- NOTE**
- The PIN code can be viewed in this dialog box. Make sure that it is not seen by another user.
  - If you forget the PIN code, you will be unable to open the corresponding project file.

### ● [OK] button

Updates the settings and closes the dialog box.

If you are online, these settings will be transmitted to all MTX/MRX units in the project.

If you are offline, they will be transmitted when you go online.

### ● [Cancel] button

Closes the dialog box without updating the settings.

## “Security” dialog box

When you open a project file for which a PIN code has been specified, the “Security” dialog box appears.

Enter the PIN code, and click the [OK] button.

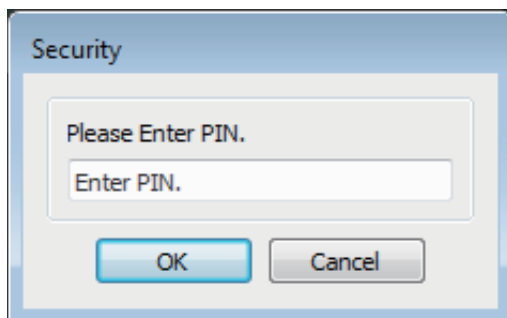

## □ "Project Information" dialog box

---

Allows you to include a memo in the project file to record property information or contact information.

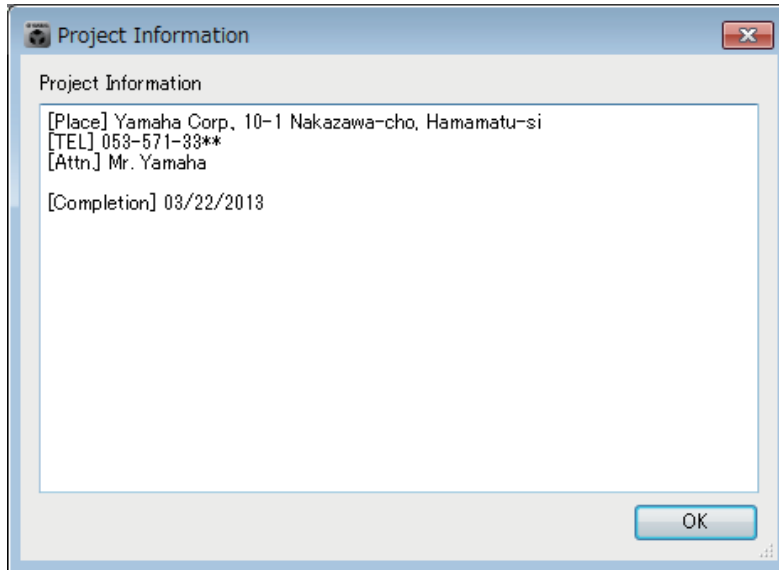

## □ “Configuration Diagram” dialog box

Displays a diagram that shows how devices such as the MTX/MRX, XMV, and DCP are connected. The configuration diagram can be printed.

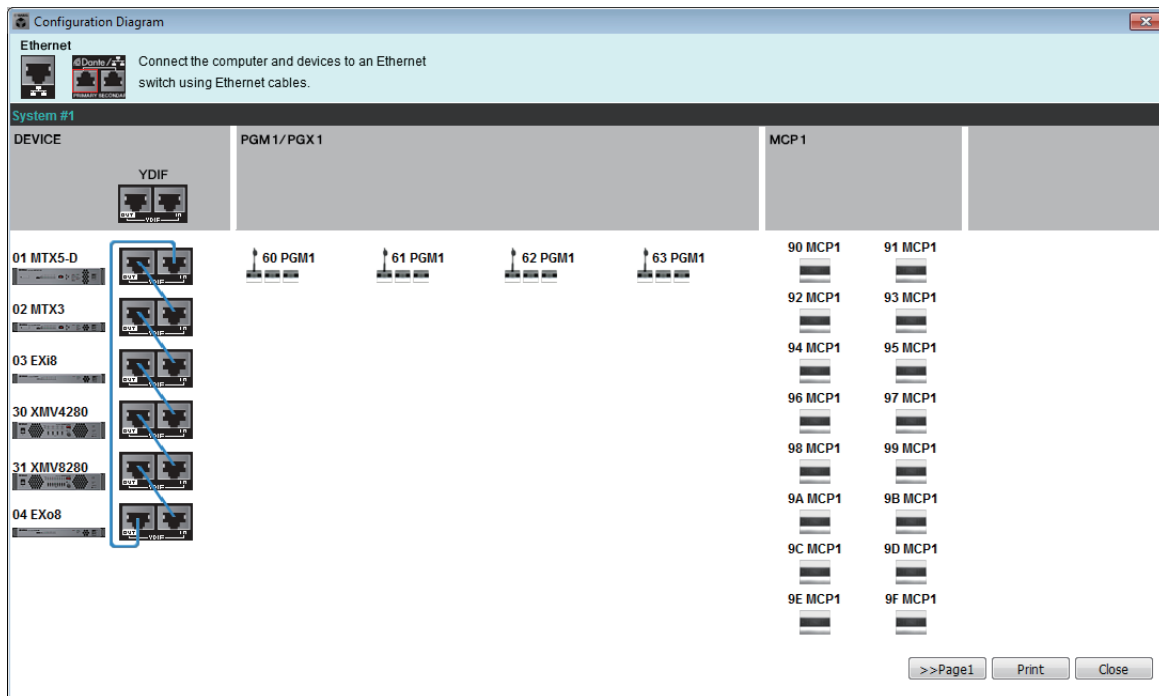
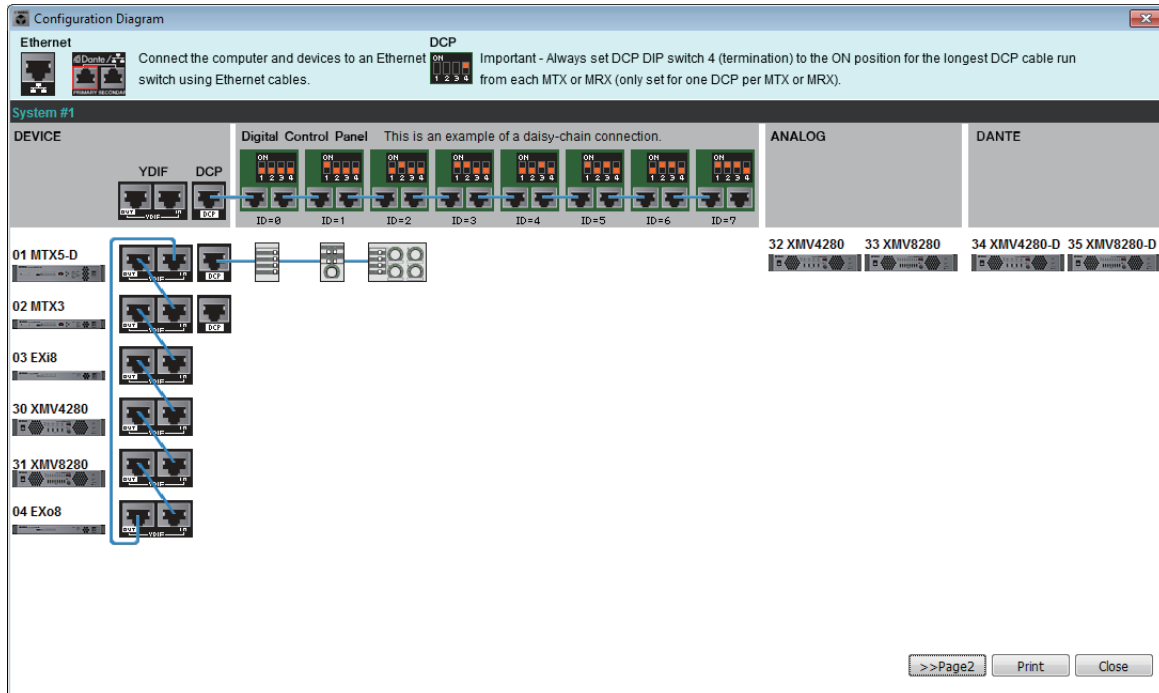

- **[>>Page 2]/[>>Page 1] buttons**  
Switch between configuration diagram screens.
- **[Print] button**  
Starts printing the configuration diagram.
- **[Close] button**  
Closes the dialog box without printing the configuration diagram.

## □ "Get Log" dialog box

A record of the MTX/MRX system's operation is stored as a "log" in the MTX/MRX's internal memory. In this dialog box you can output the logs of all MTX/MRX units existing on the subnet to which your computer is connected, and save them as a file. The log file is in ".csv" format.

- NOTE**
- The Project screen's [Alert] tab does not show the information listed in the alert list, but this is captured in the log.
  - The MCP1 and PGM1/PGX1 are not subject to capture in the log.

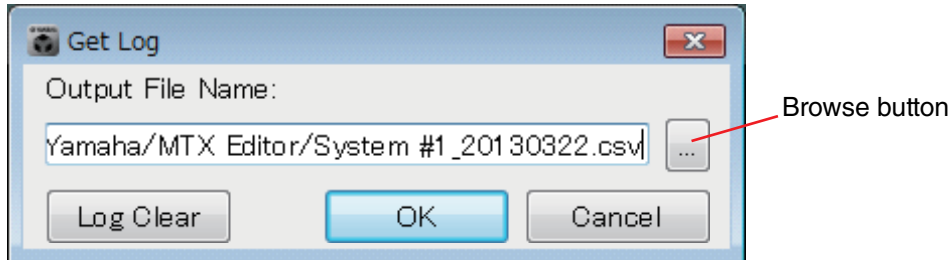

### ● [Output File Name] box

Shows the location (absolute path) in which the log file is saved. You can also enter this directly.

### ● Browse button

Opens the file browser and selects the file that will be output as the log.

### ● [Log Clear] button

Deletes the log for all MTX/MRX units existing on the subnet.

When you click this button, a confirmation message will appear. If you click the [Yes] button, the log will be deleted. If you click the [No] button, the operation will be cancelled and the dialog box will close. You may be asked to enter the PIN code.

### ● [OK] button

Outputs the log file and closes the dialog box.

### ● [Cancel] button

Cancels log file output and closes the dialog box.

## □ "Sampling Rate Converter" dialog box

Here you can turn on/off the SRC (Sampling Rate Converter) of the MY4-AEC or MY8-AE96S that is installed in the device's slot, and specify the word clock setting of the output.

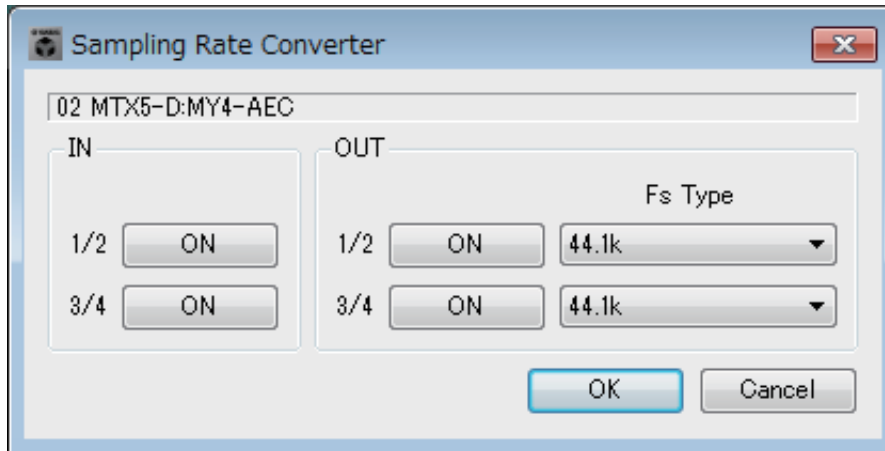

- **[ON] button**

Switches the SRC on/off. The button also shows the on/off status.

- **[Fs Type] box (MY4-AEC only)**

This selects the word clock that will be output from the MY4-AEC when SRC is on. If you select AES/EBU\_IN\_CH1/2, the word clock that is received at input 1/2 of the MY4-AEC will be output. If you select AES/EBU\_IN\_CH3/4, the word clock that is received at input 3/4 of the MY4-AEC will be output.

- **[OK] button**

Applies the settings and closes the dialog box.

- **[Cancel] button**

Closes the dialog box without applying the settings.

## □ “Input Source/Redundant” dialog box

Here you can specify for each channel whether the input source to the XMV will be digital or analog. If the input source is specified as digital, you can specify that the input source will switch from digital to analog when a pilot tone or analog input is detected. Here we explain the screen for when the digital input is YDIF.

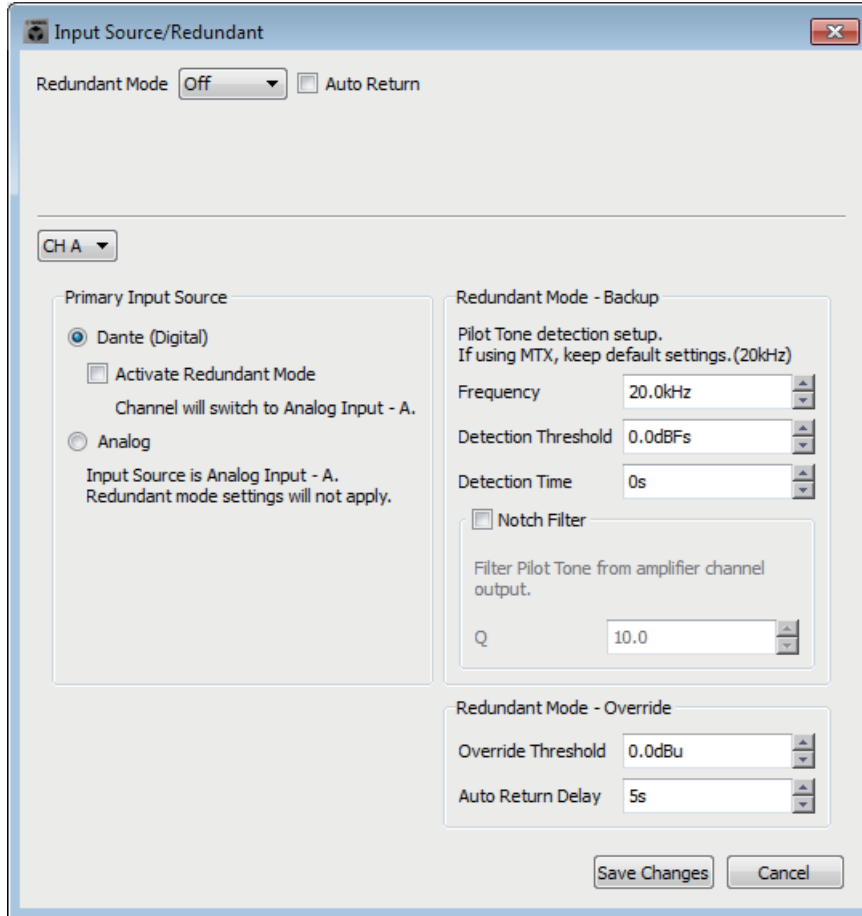

### ● [Redundant Mode] list box

Selects the redundancy method.

- [Off]  
Redundancy is not used.
- [Backup]  
Switch to analog input when the pilot tone of the digital input is interrupted due to a broken connection or other problem.
- [Override]  
Switch the digital input to the prescribed analog input when analog audio is detected.

### ● [Auto Return] check box

If this check box is selected, operation will be as follows.

- **In the case of Backup mode**  
When the digital input returns, the input source is switched to digital.
- **In the case of Override mode**  
When the analog input falls below the threshold value, the input source is returned from analog to digital.

- **Channel list box**

Selects the input channel for which to make settings.

- **“Primary Input Source” area**

Here you can specify for each channel whether the input will be digital or analog.

- **[YDIF (Digital)]/[Dante (Digital)] option button**

The signal of the corresponding channel is taken from YDIF or Dante.

Use the “EXT.I/O” screen to specify the YDIF or Dante patching.

- **[Redundant] check box**

If this check box is selected, the redundancy function is enabled.

The [Redundant Mode] list box determines the redundancy mode. If [Off] is selected, the redundancy function is disabled even if this check box is selected.

- **[Analog] option button**

The signal is taken from the analog input jack of the same name as the corresponding channel.

- **“Redundant Mode - Backup” area**

Here you can specify how the pilot tone is detected for each channel. Specify 20.0 kHz if you’re using the pilot tone of the MTX5-D.

- **[Frequency] spin box**

Specifies the center frequency of the pilot tone.

- **[Detection Threshold] spin box**

Specifies the input level threshold value for the pilot tone. Input that exceeds the threshold value is considered to be the pilot tone.

- **[Detection Time] spin box**

Specifies the detection time for the pilot tone. If the pilot tone can not be detected for the specified time interval, it is determined that the input has ceased.

- **[Notch Filter] check box**

If this check box is selected, a notch filter is enabled to eliminate the frequency component of the pilot tone so that the pilot tone is not output from the amp.

- **[Q] spin box**

Specifies the width of the frequency band for the notch filter.

- **“Redundant Mode - Override” area**

Here you can specify the conditions under which each channel will switch to the analog input in Override mode.

- **[Override Threshold] spin box**

Specifies the threshold value for the analog input. When the threshold value is exceeded, the input source will switch to analog.

- **[Auto Return Delay] spin box**

If the [Auto Return] check box is selected, this specifies the time after the analog input falls below the threshold value until the input is switched back to the digital input.

- **[Save Changes] buttons**

Saves the settings and closes the dialog box.

- **[Cancel] button**

Discards the changes and closes the dialog box.

# Appendix

## List of settings in “Settings” dialog boxes

This section explains the settings in the following “Settings” dialog boxes.

For details about settings that are unique to the MRX series, refer to “MRX Designer User Guide.”

- DCP/Wireless DCP/MCP1
- GPI Input
- GPI Output

### ■ DCP/Wireless DCP/MCP1

Settings for the switches and knobs/sliders of the DCP, the Wireless DCP, or MCP1 are explained here.

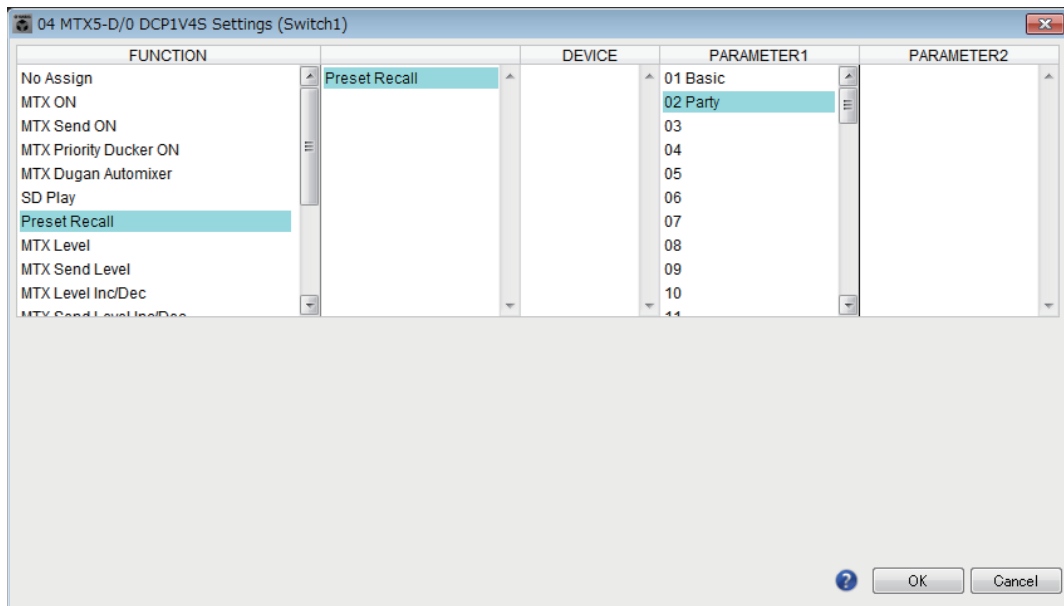

#### ● If [FUNCTION] is [No Assign]

Use this setting if you don't want the switch or the knob/slider of the controller to change any setting. This is unavailable for [DEVICE] and for [PARAMETER 1/2].

#### ● If [FUNCTION] is [Open Page] (only for the HOME page of the MCP1)

The switch of the MCP1 changes pages of the MCP1.

#### ● If [FUNCTION] is [MTX ON] (switch only)

The switch turns the parameter on/off.

Select one of the following parameter types, and then make the appropriate setting.

- Input Ch ON
- Fx RTN ON
- ZONE Out ON
- Output Ch ON
- Input Ch Mute Group
- ZONE Out Mute Group

**NOTE** In the case of Input Ch Mute Group and ZONE Out Mute Group, the unit's LED is unlit when mute is on.

- **[DEVICE]**  
Select the device that you want to change. These are shown in order of UNIT ID and model name.

- **[PARAMETER1]**  
Specify the channel that will control the on/off setting of the parameter.

● **If [FUNCTION] is [MTX Send ON] (switch only)**

The switch turns the send on/off.

Select one of the following parameter types, and then make the appropriate setting.

- Input Ch Send ON
- Fx RTN Send ON

- **[DEVICE]**  
Select the device that you want to change. These are shown in order of UNIT ID and model name.

- **[PARAMETER1][PARAMETER2]**  
Specify the channel that will control send on/off.

● **If [FUNCTION] is [MTX Priority Ducker ON] (switch only)**

The switch turns the zone's Ducker on/off.

Select one of the following parameter types, and then make the appropriate setting.

- 1st Priority
- 2nd Priority

- **[DEVICE]**  
Select the device that you want to change. These are shown in order of UNIT ID and model name.

- **[PARAMETER 1]**  
Select the ZONE that will control Ducker on/off.

● **If [FUNCTION] is [MTX Dugan Automixer] (switch only)**

The switch turns the parameter on/off.

Select one of the following parameter types, and then make the appropriate setting.

- Override (master)
- Mute (master)
- override (Ch)

- **[DEVICE]**  
Select the device that you want to change. These are shown in order of UNIT ID and model name.

- **[PARAMETER 1]**  
For Override (master) and Mute (master), select the group that controls on/off. For override (Ch), select the channel that controls on/off.

## ● If [FUNCTION] is [SD Play] (switch only)

Play/stop the audio file that is specified by the switch.

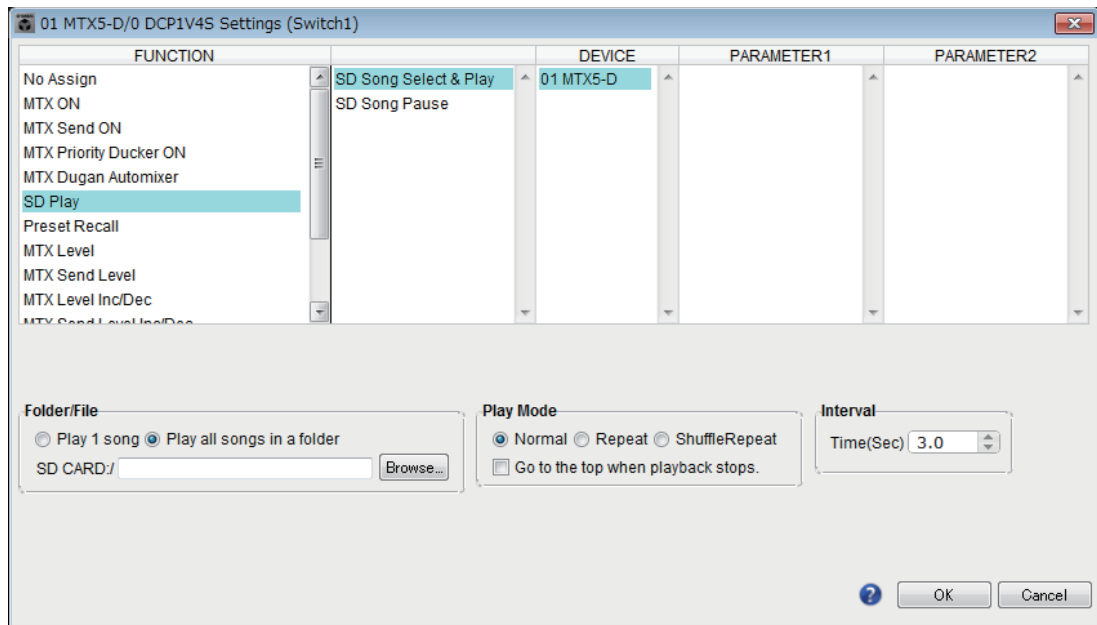

Select one of the following parameter types, and then make the appropriate setting.

- SD Song Select & Play
- SD Song Pause

### ○ [DEVICE]

Select the device that you want to change. These are shown in order of UNIT ID and model name.

### ○ [Folder/File] (only if parameter type is [SD Song Select & Play])

Here you can select the song or folder that you want to play from the SD memory card.

#### ◆ [Play 1 song]/[Play all songs in a folder]

If you choose [Play 1 song], only the song currently selected in [SD CARD:/] will play.  
If you select [Play all songs in a folder], all songs saved in the folder selected by [SD CARD:/] will play.

**NOTE** Up to 100 songs will be played in ascending order of their file name.

#### ◆ [SD CARD:/] box

This shows the name of the song that will be played, or the name of the folder. You can change the name, or enter it directly.

**NOTE** You can also enter Japanese.

#### ◆ [Browse] button

#### If [Play 1 song] is selected

Select the file shown in [SD CARD:/].

The following file and folder formats can be shown.

- (folder name)\(file name).mp3
- (folder name)\(file name).wav
- (file name).mp3
- (file name).wav

**If [Play all songs in a folder] is selected**

Select the folder shown in [SD CARD:/]. Up to 100 songs saved in the currently selected folder will play.

The following folder formats can be shown.

- (folder name)
- blank

**NOTE** - Only first-level folders are valid.

- If the folder name is blank, the songs that exist in the root level of the memory card will be played (folders below the root level will not be included).

○ **[Play Mode] (only if parameter type is [SD Song Select & Play])**

◆ **[Normal]/[Repeat]/[Shuffle Repeat]**

This specifies the play mode for the song or songs.

If you choose [Normal], the specified song or songs in the folder will play once.

If you choose [Repeat], the specified song or songs in the folder will play repeatedly.

If you choose [Shuffle Repeat], the songs in the specified folder will play repeatedly in random order. If you choose [Play 1 song] in [Folder/File], the [Shuffle Repeat] setting will be unavailable.

◆ **[Go to the top when playback stops.]**

When you stop song playback, this specifies whether the song will pause at the location where you stopped or will return to the beginning of the song.

If this is on, playback will begin from the beginning of the song or the first song in the folder the next time you start playback.

If this is off, playback will begin from the location at which you stopped the next time you start playback.

● **If [FUNCTION] is [Preset Recall] (switch only)**

The preset specified by the switch will be recalled.

○ **[PARAMETER1]**

Selects the preset number that will be recalled.

● **If [FUNCTION] is [MTX Level] or [MTX Send Level]**

**In the case of Knob/Slider/MCP1**

The knob, slider, or MCP1 switch controls the level or send level.

Select one of the following parameter types, and then make the appropriate setting.

**In the case of MTX Level**

- Input Ch Level
- Fx RTN Level
- Matrix Out Level
- ZONE Out Level
- Output Ch Level
- 1st Priority Mix Level
- 2nd Priority Mix Level
- Input Ch DCA Group
- ZONE Out DCA Group

**NOTE** If you want to control multiple input channels, use [Input Ch DCA Group] or [ZONE Out DCA Group].

**In the case of MTX Send Level**

- Input Ch Send Level
- Fx RTN Send Level

- **[DEVICE]**  
Select the device that you want to change. These are shown in order of UNIT ID and model name.
- **[PARAMETER1]/[PARAMETER2]**  
Specify the channel whose level will be controlled.
- **[Parameter Range]**  
Use [Upper Limit] and [Lower Limit] to specify the range in which the level can be varied.  
If [Mute Enable] is on, the mute state ( $-\infty$  dB) will be enabled if the level is lowered below the value specified by [Lower Limit].
  - NOTE**
    - If the nominal value specified by the following [Nominal Value] is higher than the [Upper Limit], the [Upper Limit] will rise in tandem with the [Nominal Value]. Conversely, if the nominal value goes below the [Lower Limit], the [Lower Limit] will fall in tandem with the [Nominal Value].
    - By using [Parameter Range] you can limit the range in which the user can control the volume. For example you can use this to specify the maximum volume of background music, or use a controller to make fine volume adjustments in a narrow range of  $-6$  dB –  $+6$  dB.
- **[Nominal] check box (DCP only)**  
Here you can make settings for the Nominal function.  
By specifying the nominal value, you can assign a specific LED position as the normal volume setting. For example by specifying the center LED as the volume setting for normal use and setting the maximum value to the maximum volume that is allowable for the system, you can prevent damage to the system that might occur if the volume of the background music were raised during a noisy time.  
If the check box is selected, the Nominal function will be on.  
[Nominal Value] specifies the nominal value.  
[Nominal LED Position] specifies the LED position that will light when the level reaches the nominal value.  
If the check box is cleared (Nominal function off), both parameters will be grayed-out and unavailable.
- **[Knob] (DCP only)**  
Here you can make settings for the DCP’s knobs.  
[Sensitivity] specifies the sensitivity at which the parameter will change when the DCP’s knob is rotated.  
If [Acceleration] is on, the parameter will change faster if the knob is rotated more rapidly. If [Fast] is selected as the [Sensitivity], the [Acceleration] setting is dimmed and unavailable.
- **[Switch] (MCP1 only)**  
Here you can make settings for the MCP1’s switches.  
[Sensitivity] specifies the sensitivity at which the parameter will change when the MCP1’s switch is touched.

#### **In the case of a switch (DCP1V4S–US/EU only)**

Use the switch to change what will be controlled by the knob.

Choose this if you want the knob to have more than one function.

If the switch is set to [MTX Level] or [MTX Send Level], the knob operation select button will be dimmed, and you won’t be able to make knob settings.

For details on the various settings, refer to the case for knobs/sliders described above.

## ● If [FUNCTION] is [MTX Level Inc/Dec] or [MTX Send Level Inc/Dec] (DCP switches only)

Use the switch to change the level or send level.

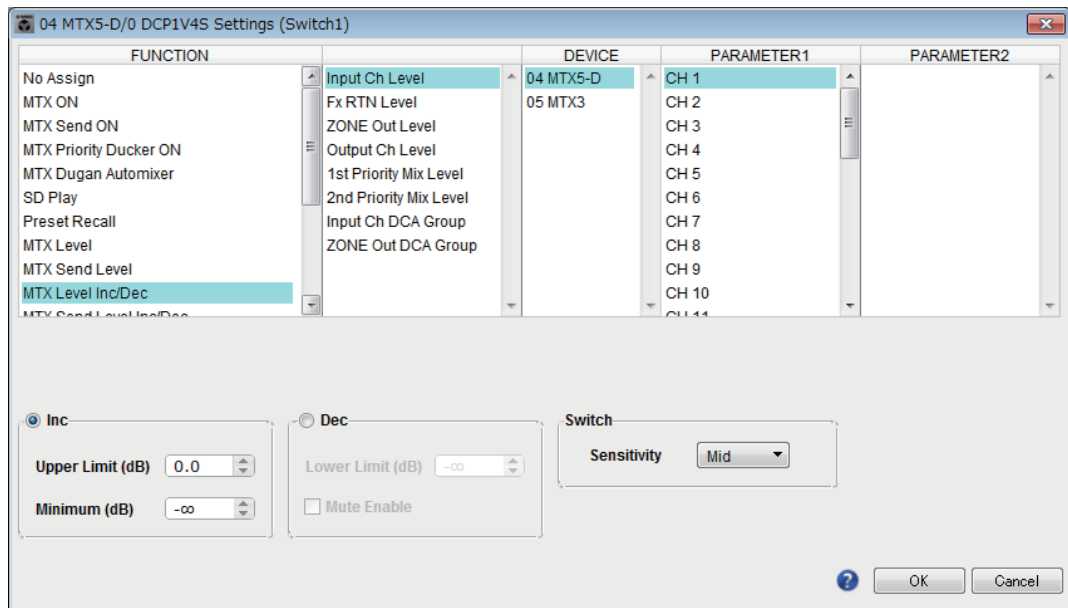

Select one of the following parameter types, and then make the appropriate setting.

### If [FUNCTION] is [MTX Level Inc/Dec]

- Input Ch Level
- Fx RTN Level
- Matrix Out Level
- ZONE Out Level
- Output Ch Level
- 1st Priority Mix Level
- 2nd Priority Mix Level
- Input Ch DCA Group
- ZONE Out DCA Group

### If [FUNCTION] is [MTX Send Level Inc/Dec]

- Input Ch Send Level
- Fx RTN Send Level

### ○ [DEVICE]

Select the device that you want to change. These are shown in order of UNIT ID and model name.

### ○ [PARAMETER1]/[PARAMETER2]

Specifies the channel for which the level or send level will be raised or lowered. If [FUNCTION] is [Send Level Inc/Dec], use [PARAMETER2] to set ZONE, Fx, and ANC.

### ○ [Inc]

If you select this option, pressing the switch repeatedly will raise the level or the send level.

#### ◆ [Upper Limit]

Specifies the maximum level achieved when you press the switch.

#### ◆ [Minimum]

If the current parameter value is lower than the value specified here, pressing the switch once will set the parameter to this value.

○ **[Dec]**

If you select this option, pressing the switch repeatedly will lower the level or the send level.

◆ **[Lower Limit]**

Specifies the minimum level to be achieved when you press the switch.

◆ **[Mute Enable] check box**

If this option is selected, the Mute state ( $-\infty$  dB) will be enabled if the level is lowered below the value specified by [Lower Limit].

○ **[Switch]**

Allows you to make switch-related settings.

[Sensitivity] specifies the point at which the parameter will change when the switch is pressed.

● **If [FUNCTION] is [MTX Source Select] (DCP/Wireless DCP)**

The switch that is assigned to [Input Ch Send ON] will select the send point of the Matrix, and the switch/knob/slider that is assigned to [Input Ch Send Level] will adjust the level of the send point.

**Using a knob/slider to adjust the send level (other than DCP4S–EU/US)**

Shown below is an example of using a switch to turn send on/off and using a knob/slider to adjust the send level.

FUNCTION : MTX Source Select (1)

Settings (Switch1)

FUNCTION		DEVICE	PARAMETER 1	PARAMETER 2
MTX send Level Inc/Dec MTX Source Select	Input Ch Send On Input Ch Send Level	01 MTX5-D	Zone1 Zone2 Zone3	<input checked="" type="checkbox"/> CH 1 <input type="checkbox"/> CH 2 <input type="checkbox"/> CH 3

ON OFF IGNORE

Settings (Switch2)

FUNCTION		DEVICE	PARAMETER 1	PARAMETER 2
MTX send Level Inc/Dec MTX Source Select	Input Ch Send On Input Ch Send Level	01 MTX5-D	Zone1 Zone2 Zone3	<input type="checkbox"/> CH 1 <input checked="" type="checkbox"/> CH 2 <input type="checkbox"/> CH 3

ON OFF IGNORE

Settings (Knob1)

FUNCTION		DEVICE	PARAMETER 1	PARAMETER 2
MTX send Level Inc/Dec MTX Source Select	Source Select Input Ch Send Level	01 MTX5-D	Zone1 Zone2 Zone3	

The switch settings and knob/slider settings for this example are explained below.

**Switch settings**

Select the following parameter type to be controlled by the switch, and then make the appropriate settings.

- Input Ch Send On

○ **[DEVICE]**

Select the device that you want to change. These are shown in order of UNIT ID and model name.

○ **[PARAMETER1]/[PARAMETER2]**

In the [PARAMETER1] column, select the target ZONE.

In the [PARAMETER2] column, click ? on the left of the channel name to select ON, OFF, or IGNORE for the desired channels. “On” can be specified only for one channel.

**Knob/Slider settings**○ **[DEVICE]**

Select the device that you want to change. These are shown in order of UNIT ID and model name.

○ **[PARAMETER1]**

In the [PARAMETER1] column, select the target ZONE.

○ **[Parameter Range]**

Use [Upper Limit] and [Lower Limit] to specify the range in which the level can be varied.

If [Mute Enable] is on, the Mute state ( $-\infty$  dB) will be enabled if the level is lowered below the value specified by [Lower Limit].

- NOTE** - If the nominal value specified by the following [Nominal Value] is higher than the [Upper Limit], the [Upper Limit] will rise in tandem with the [Nominal Value]. Conversely, if the nominal value goes below the [Lower Limit], the [Lower Limit] will fall in tandem with the [Nominal Value].
- By using [Parameter Range] you can limit the range in which the user can control the volume. For example you can use this to specify the maximum volume of background music, or use the controller to make fine volume adjustments in a narrow range of  $-6$  dB  $- +6$  dB.

○ **[Nominal] check box (DCP only)**

Here you can make settings for the Nominal function.

By specifying the nominal value, you can assign a specific LED position as the normal volume setting. For example by specifying the center LED as the volume setting for normal use and setting the maximum value to the maximum volume that is allowable for the system, you can prevent damage to the system that might occur if the volume of the background music were raised during a noisy time.

If the check box is selected, the Nominal function will be on.

[Nominal Value] specifies the nominal value.

[Nominal LED Position] specifies the LED position that will light when the level reaches the nominal value.

If the check box is cleared (Nominal function off), both parameters will be grayed-out and unavailable.

○ **[Knob] (DCP only)**

Here you can make settings for the DCP’s knobs.

[Sensitivity] specifies the sensitivity at which the parameter will change when the knob is rotated.

If [Acceleration] is on, the parameter will change faster if the knob is rotated more rapidly. If [Fast] is selected as the [Sensitivity], the [Acceleration] setting is dimmed and unavailable.

### Using switches to adjust the send level

Shown below is an example of using switches to turn send on/off and to adjust the send level.

FUNCTION : MTX Source Select (2)

Settings (Switch1)

FUNCTION		DEVICE	PARAMETER 1	PARAMETER 2
MTX send Level Inc/Dec MTX Source Select	Input Ch Send On Input Ch Send Level	01 MTX5-D	Zone1 Zone2 Zone3	<input checked="" type="checkbox"/> CH 1 <input type="checkbox"/> CH 2 <input type="checkbox"/> CH 3

ON  OFF  IGNORE

Settings (Switch2)

FUNCTION		DEVICE	PARAMETER 1	PARAMETER 2
MTX send Level Inc/Dec MTX Source Select	Input Ch Send On Input Ch Send Level	01 MTX5-D	Zone1 Zone2 Zone3	<input type="checkbox"/> CH 1 <input checked="" type="checkbox"/> CH 2 <input type="checkbox"/> CH 3

ON  OFF  IGNORE

Settings (Switch3)

FUNCTION		DEVICE	PARAMETER 1	PARAMETER 2
MTX send Level Inc/Dec MTX Source Select	Source Select Input Ch Send Level	01 MTX5-D	Zone1 Zone2 Zone3	

Inc  Dec

Settings (Switch4)

FUNCTION		DEVICE	PARAMETER 1	PARAMETER 2
MTX Source Select(w/sw) MTX Xpoint	Source Select Input Ch Send Level	01 MTX5-D	Zone1 Zone2 Zone3	

Inc  Dec

The switch settings for this example are explained below.

**Switch settings**

Select the following parameter types to be controlled by the switches, and then make the appropriate settings.

- Input Ch Send On
- Input Ch Send Level

○ **[DEVICE]**

Select the device that you want to change. These are shown in order of UNIT ID and model name.

○ **[PARAMETER1]/[PARAMETER2]**

In the [PARAMETER1] column, select the target ZONE.

For Input Ch Send On, click the ? at the left of the channel name in the [PARAMETER2] column to select ON, OFF, or IGNORE for the desired channels. “On” can be specified only for one channel.

For Input Ch Send Level, set the following parameters as well.

○ **[Inc]**

If you select this option, pressing the switch each time will raise the level or the send level.

◆ **[Upper Limit]**

Specifies the maximum level achieved when you press the switch.

◆ **[Minimum]**

If the current parameter value is lower than the value specified here, pressing the switch once will set the parameter to this value.

○ **[Dec]**

If you select this option, pressing the switch each time will lower the level or the send level.

◆ **[Lower Limit]**

Specifies the minimum level achieved when you press the switch.

◆ **[Mute Enable] check box**

If this is on, the Mute state ( $-\infty$  dB) will be enabled if the level is lowered below the value specified by [Lower Limit].

○ **[Switch]**

Allows you to make switch-related settings.

[Sensitivity] specifies the sensitivity at which the parameter will change when the switch is pressed.

● If [FUNCTION] is [MTX Source Select] (MCP1)

The switch that is assigned to [Input Ch Send ON] will select the send point of the Matrix, and the switch/knob/slider that is assigned to [Input Ch Send Level] will adjust the level of the send point.

FUNCTION : MTX Source Select

Settings (SwitchL1)

FUNCTION		DEVICE	PARAMETER 1	PARAMETER2
MTX send Level	Input Ch Send On	01 MTX5-D	Zone1	<input checked="" type="checkbox"/> CH 1
MTX Source Select	Input Ch Send Level		Zone2 Zone3	<input type="checkbox"/> CH 2 <input type="checkbox"/> CH 3

ON  OFF  IGNORE

Settings (SwitchR1)

FUNCTION		DEVICE	PARAMETER 1	PARAMETER2
MTX send Level	Input Ch Send On	01 MTX5-D	Zone1	<input type="checkbox"/> CH 1
MTX Source Select	Input Ch Send Level		Zone2 Zone3	<input checked="" type="checkbox"/> CH 2

ON  OFF  IGNORE

Settings (SwitchL3)

FUNCTION		DEVICE	PARAMETER 1	PARAMETER2
MTX send Level	Input Ch Send On	01 MTX5-D	Zone1	
MTX Source Select	Input Ch Send Level		Zone2 Zone3	

ON  OFF  IGNORE

Touch

Touch

We will explain the switch settings in this example.

Select the following parameter types to be operated by the switches, and then make various settings.

- Input Ch Send On
- Input Ch Send Level

○ **[DEVICE]**

Select the device that you want to change. These are shown in order of UNIT ID and model name.

○ **[PARAMETER1]/[PARAMETER2]**

In the [PARAMETER1] column, select the target ZONE.

In the case of Input Ch Send On, click the ? located at the left in [PARAMETER2], to specify the channel's state as ON/OFF/IGNORE. OFF can be specified only for one channel.

In the case of Input Ch Send Level, set the following parameters as well.

○ **[Parameter Range]**

◆ **[Upper Limit]**

Specifies the maximum level achieved by pressing the switch.

◆ **[Lower Limit]**

Specifies the minimum level achieved when you press the switch.

◆ **[Mute Enable] check box**

If this check box is selected, the Mute state ( $-\infty$  dB) will be enabled if the level falls below the value specified by [Lower Limit].

○ **[Switch]**

Allows you to make switch-related settings.

[Sensitivity] specifies the sensitivity at which the parameter will change when the switch is touched.

## ● If [FUNCTION] is [Legacy - MTX Source Select w/knob] (only for switches of a DCP equipped with knobs)

You can control the send on/off for multiple channels via switches, and control the send level for any channel via knobs.

**NOTE** If you assign the same source to multiple DCP units and then change the settings on one of the DCP units, the changes will not be updated on other DCP units. Each DCP unit will retain the settings (LED status and knob assignments) that were made on it.

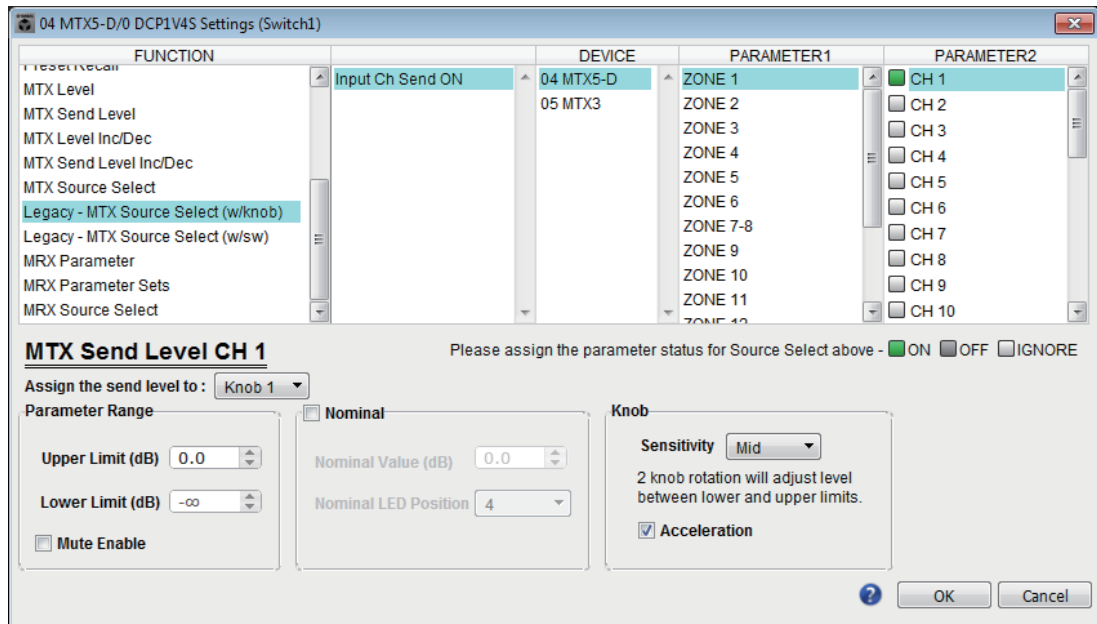

### ○ [DEVICE]

Select the device that you want to change. These are listed in order of UNIT ID and model name.

### ○ [PARAMETER1]/[PARAMETER2]

In the [PARAMETER1] column, select the target ZONE.

In the [PARAMETER2] column, click  to the left of the channel name to select ON, OFF, or IGNORE for the desired channels. The ON/OFF/IGNORE setting can be applied to multiple channels simultaneously. If you select an ON channel, the bottom half of the dialog box will display parameter fields related to the knobs.

### ○ [Assign the send level to:] box

Enables you to select a knob that will control the send level of the currently-selected channel.

Only one channel can be assigned to a knob.

### ○ [Parameter Range]/[Nominal]/[Knob]

Enable you to make a setting for the knob that has been specified in the [Assign the send level to:] box. For details about the settings, refer to [If \[FUNCTION\] is \[MTX Level\]](#) for knobs/sliders.

## ● If [FUNCTION] is [Legacy - MTX Source Select w/sw] (DCP switches only)

You can control the send on/off for multiple channels via switches, and the send level for any channel via switches.

**NOTE** If you assign the same source to multiple DCP units and then change the settings on one of the DCP units, the changes will not be updated on other DCP units. Each DCP unit will retain the settings (LED status and knob assignments) that were made on it.

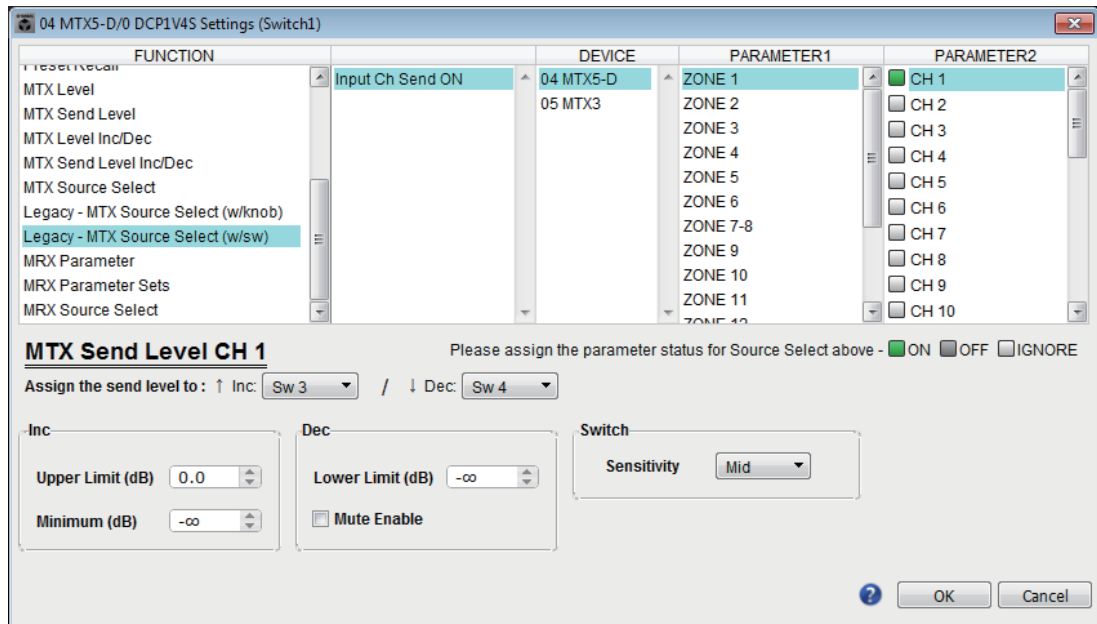

### ○ [DEVICE]

Select the device that you want to change. These are listed in order of UNIT ID and model name.

### ○ [PARAMETER1]/[PARAMETER2]

In the [PARAMETER1] column, select the target ZONE.

In the [PARAMETER2] column, click  to the left of the channel name to select ON, OFF, or IGNORE for the desired channels. The ON/OFF/IGNORE setting can be applied to multiple channels simultaneously. If you select an ON channel, the bottom half of the dialog box will display the switch-related setting items.

### ○ [Assign the send level to:] box

Enables you to assign a function that raises or lowers the send level of the selected channels to other switches.

### ○ [Inc]/[Dec]/[Switch]

Enable you to make settings for the switches specified in the [Assign the send level to:] box. For details about the settings, refer to [If \[FUNCTION\] is \[MTX Send Level Inc/Dec\]](#) for switches.

## ■ GPI Input

This section explains settings for the [GPI IN] connector of the device itself.

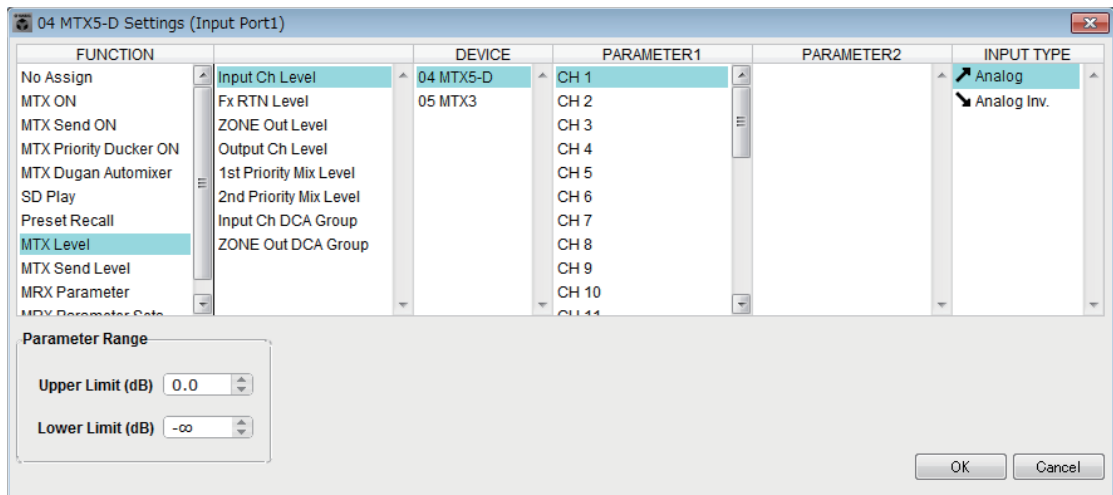

### Connection examples using the [GPI IN] connector

#### Connection example 1:

##### Controlling the MTX/MRX with a switch

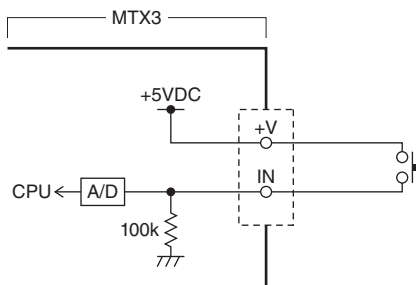

#### Connection example 2:

##### Controlling the MTX/MRX with a 10kΩ B-curve variable resistor

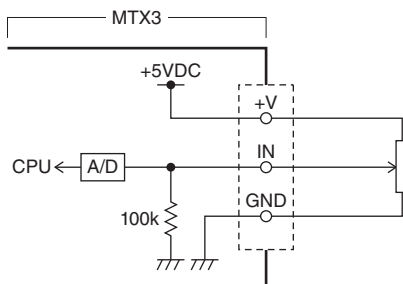

### About [INPUT TYPE]

[INPUT TYPE] allows the following settings.

- Analog
- Analog Inv.
- High Active
- Low Active
- Rising Edge
- Falling Edge

- NOTE**
- The threshold value at which on/off switching will occur will be the middle value between the maximum and minimum input voltage values (the value equal to the sum of the maximum and minimum values divided by two). To prevent malfunctions, you should allow plenty of room for detection (see “GPI Calibration” dialog box).
  - If the voltage has dropped because of cable length or noise, use the “GPI Calibration” dialog box to adjust the maximum and minimum input voltage values. Since voltage may become unstable, configure and set up your external circuit to ensure that there is ample distance between the maximum and minimum values.
  - You can indicate the on/off status by assigning ON to one of the GPI Output ports.

○ ↗ **Analog**

Use this if you selected [Level] or [Send Level] as the [FUNCTION].

The level will be at the maximum value when the input voltage to the GPI IN is at maximum (5V), and at the minimum value when the input voltage is at minimum (0V).

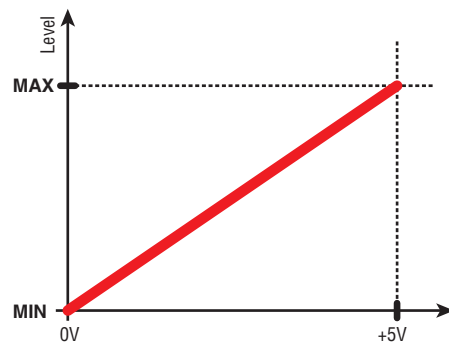

○ ↘ **Analog Inv.**

Use this if you selected [Level] or [Send Level] as the [FUNCTION].

The level will be at the minimum value when the input voltage to the GPI IN is at maximum (5V), and at the maximum value when the input voltage is at minimum (0V).

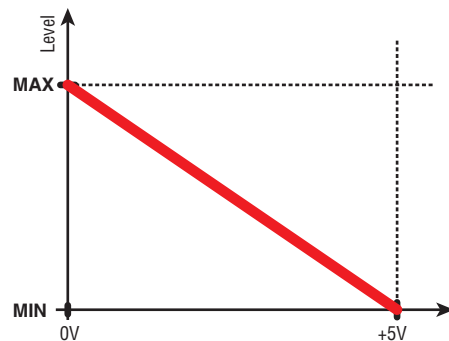

○ ↕ **High Active**

Use this if you selected [ON] or [Send ON] as the [FUNCTION].

The function will turn on when the input voltage to GPI IN rises above the center voltage, and will turn off when it falls below the center voltage.

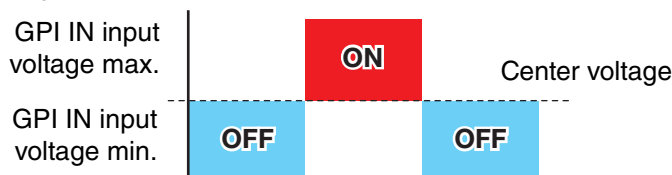

- NOTE** If you've selected [Input Ch Mute Group] or [Zone Out Mute Group] as the parameter type, mute on/off will be switched.

○ **↘ Low Active**

Use this if you selected [ON] or [Send ON] as the [FUNCTION].

The function will turn off when the input voltage to GPI IN rises above the center voltage, and will turn on when it falls below the center voltage.

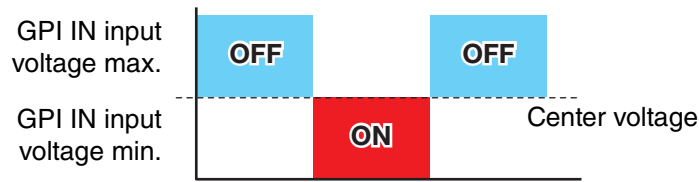

**NOTE** If you've selected [Input Ch Mute Group] or [Zone Out Mute Group] as the parameter type, mute on/off will be switched.

○ **⤴ Rising Edge**

Use this if you selected [ON]/[Send ON]/[SD Play]/[Preset Recall] as the [FUNCTION].

The parameter will alternately turn on/off or play/stop etc. when the input voltage to GPI IN changes from below the center voltage to above it.

[Preset Recall] will recall the specified preset when the input voltage changes from below the center voltage to above it.

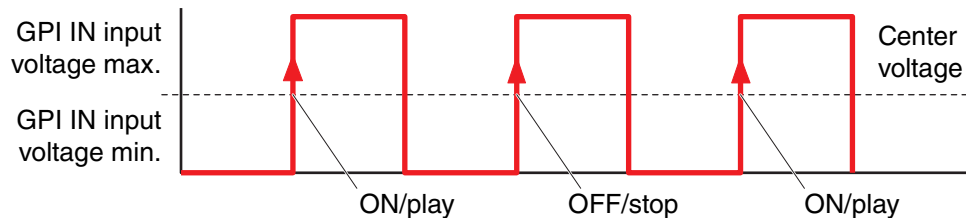

○ **⤵ Falling Edge**

Use this if you selected [ON]/[Send ON]/[SD Play]/[Preset Recall] as the [FUNCTION].

The parameter will alternately turn on/off or play/stop etc. when the input voltage to GPI IN changes from above the center voltage to below it.

**NOTE** [Preset Recall] will recall the specified preset when the input voltage changes from below the center voltage to above it.

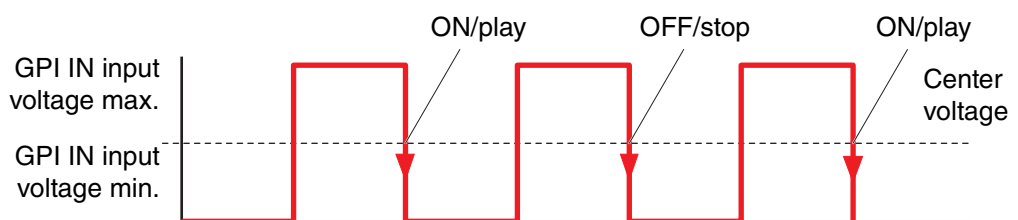

● **If [FUNCTION] is [No Assign]**

With this setting, no function will be operated by the signal that is input from the [GPI IN] connector. [DEVICE], [PARAMETER1/2], and [INPUT TYPE] will be unavailable.

### ● If [FUNCTION] is [MTX Dugan Automixer]

The input voltage to the [GPI IN] connector will turn the parameter on/off.

Select one of the following parameter types, and then make the appropriate setting.

- Override (master)
- Mute (master)
- override (Ch)

#### ○ [DEVICE]

Select the device that you want to change. These are shown in order of UNIT ID and model name.

#### ○ [PARAMETER 1]

For Override (master) and Mute (master), select the group that controls on/off. For override (Ch), select the channel that controls on/off.

#### ○ [INPUT TYPE]

Specifies how the input voltage to GPI IN will be applied to the parameter.

You can choose [High Active], [Low Active], [Rising Edge], or [Falling Edge].

### ● If [FUNCTION] is [MTX Level] (Cannot be set for PORT8)

The input voltage to the [GPI IN] connector will control the level of the channel.

If the maximum level cannot be reached because of the length of the cable, adjust the maximum and minimum input voltage values in the “[GPI Calibration](#)” dialog box.

Select one of the following parameter types, and then make the appropriate setting.

- Input Ch Level
- Fx RTN Level
- Matrix Out Level
- ZONE Out Level
- Output Ch Level
- 1st Priority Mix Level
- 2nd Priority Mix Level
- Input Ch DCA Group
- ZONE Out DCA Group

#### ○ [DEVICE]

Select the device that you want to change.

#### ○ [PARAMETER1]

Specifies the channel whose level you want to control.

#### ○ [INPUT TYPE]

Specifies how the level to GPI IN will be applied to the parameter.

You can select [Analog] or [Analog Inv.].

#### ○ [Parameter Range]

Use [Upper Limit] and [Lower Limit] to specify the range in which the level can be varied.

**NOTE** *By using [Parameter Range] you can limit the range in which the user can control the volume. For example you can use this to specify the maximum volume of background music, or use a controller to make fine volume adjustments in a narrow range of -6 dB - +6 dB.*

**● If [FUNCTION] is [MTX ON]**

Controls the on/off setting of the parameter.

Select one of the following parameter types, and then make the appropriate setting.

- Input Ch ON
- Fx RTN ON
- ZONE Out ON
- Output Ch ON
- Input Ch Mute Group
- ZONE Out Mute Group

**○ [DEVICE]**

Select the device that you want to change.

**○ [PARAMETER1]**

Specify the channel that will control the on/off setting of the parameter.

**○ [INPUT TYPE]**

Specifies how the input voltage to GPI IN will be applied to the parameter.

You can choose [High Active], [Low Active], [Rising Edge], or [Falling Edge].

**● If [FUNCTION] is [MTX Send Level] (Cannot be set for PORT8)**

The input voltage to the [GPI IN] connector will control the send level of the channel.

If the maximum level cannot be reached because of the length of the cable, adjust the maximum and minimum input voltage values in the “[GPI Calibration](#)” dialog box.

Select one of the following parameter types, and then make the appropriate setting.

- Input Ch Send Level
- Fx RTN Send Level

For details on these settings, refer to [If \[FUNCTION\] is \[MTX Level\]](#).

**● If [FUNCTION] is [MTX Send ON]**

The input voltage to the [GPI IN] connector will control the send on/off of the channel.

Select one of the following parameter types, and then make the appropriate setting.

- Input Ch Send ON
- Fx RTN Send ON

For details on these settings, refer to [If \[FUNCTION\] is \[MTX ON\]](#).

**● If [FUNCTION] is [MTX Priority Ducker ON]**

The input voltage to the [GPI IN] connector will turn the zone’s Ducker on/off.

Select one of the following parameter types, and then make the appropriate setting.

- 1st Priority
- 2nd Priority

For details on these settings, refer to [If \[FUNCTION\] is \[MTX Priority Ducker ON\] \(switch only\)](#).

### ● If [FUNCTION] is [SD Play]

The input voltage to the [GPI IN] connector will play the specified audio file. Select one of the following parameter types, and then make the appropriate setting.

- SD Song Select & Play
- SD Song Pause

For details on settings other than [INPUT TYPE], refer to [If \[FUNCTION\] is \[SD Play\] \(switch only\)](#) for switches.

#### ○ [INPUT TYPE]

Specifies how the input voltage to GPI IN will be applied to the parameter. You can choose [Rising Edge] or [Falling Edge].

### ● If [FUNCTION] is [Preset Recall]

The input voltage to the [GPI INPUT] connector will recall the specified preset.

#### ○ [PARAMETER1]

Select the preset number that you want to recall.

#### ○ [INPUT TYPE]

Specifies how the input voltage from GPI IN will be applied to the parameter. You can choose [Rising Edge] or [Falling Edge].

## ■ GPI Output

This section explains settings for the [GPI OUT] connector of the device itself. To make [GPI OUTPUT] connector settings by recalling a preset, start with “[Preset](#)” dialog box.

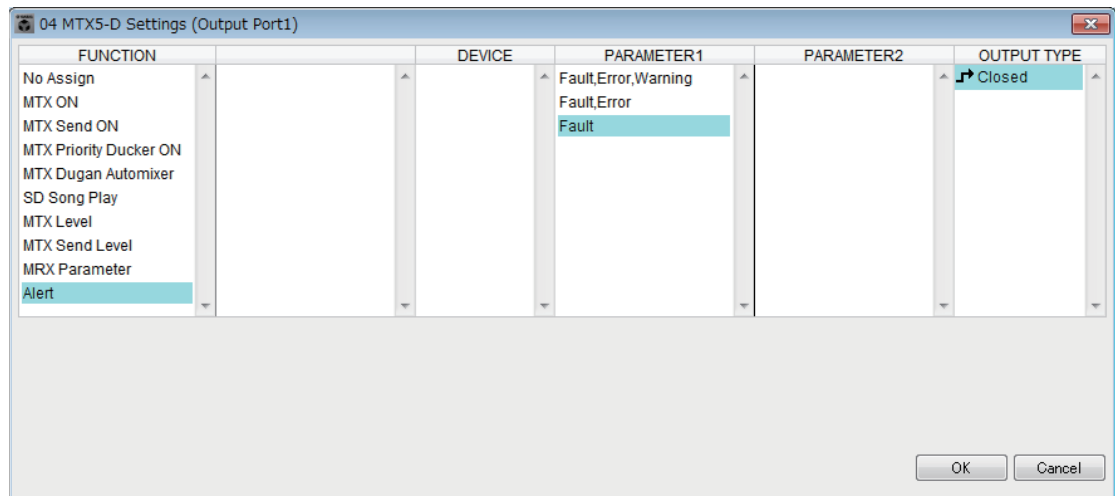



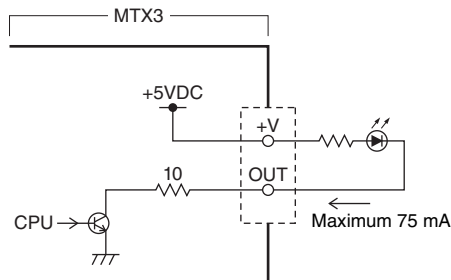

### Connection examples using the [GPI OUT] connector



**About [OUTPUT TYPE]**

[OUTPUT TYPE] allows the following settings.

-  Closed
-  Open
-  Pulse
-  Pulse Inv.

○  **Closed**

When the selected [FUNCTION] state occurs, the contact will be closed.

In the case of a parameter for which [Threshold] is specified, the contact will be closed when the threshold value is exceeded.

○  **Open**

When the selected [FUNCTION] state occurs, the contact will be opened.

In the case of a parameter for which [Threshold] is specified, the contact will be opened when the threshold value is exceeded.

**NOTE** If the [FUNCTION] is [Alert], this cannot be selected.

○  **Pulse**

If the [Direction] is [Upward], the contact will change from open to closed for approximately 250 ms when the selected [FUNCTION] state occurs. In the case of a parameter for which [Threshold] is specified, the contact will change from open to closed for approximately 250 ms when the threshold value is exceeded.

If the [Direction] is [Downward], the contact will change from open to closed for approximately 250 ms when the selected [FUNCTION] state is cleared. In the case of a parameter for which [Threshold] is specified, the contact will change from open to closed for approximately 250 ms when the value falls below the threshold.

**NOTE** If the [FUNCTION] is [SD Song Play] and [Alert], this cannot be selected.

○  **Pulse Inv.**

If the [Direction] is [Upward], the contact will change from closed to open for approximately 250 ms when the selected [FUNCTION] state occurs. In the case of a parameter for which [Threshold] is specified, the contact will change from closed to open for approximately 250 ms when the threshold value is exceeded.

If the [Direction] is [Downward], the contact will change from closed to open for approximately 250 ms when the selected [FUNCTION] state is cleared. In the case of a parameter for which [Threshold] is specified, the contact will change from closed to open for approximately 250 ms when the value falls below the threshold.

**NOTE** If the [FUNCTION] is [SD Song Play] and [Alert], this cannot be selected.

● **If [FUNCTION] is [No Assign]**

[OUTPUT TYPE] specifies the polarity of the output signal when an alert occurs. No other function are specified; they will be the default.

○ **[OUTPUT TYPE]**

Controls the GPI OUT when a preset is recalled or when a Scheduler event is executed.

**● If [FUNCTION] is [MTX Dugan Automixer]**

Parameter on/off operations will control the GPI Output.

Select one of the following parameter types, and then make the appropriate setting.

- Override (master)
- Mute (master)
- override (Ch)

**[DEVICE]**

Select the device that you want to change. These are shown in order of UNIT ID and model name.

**[PARAMETER 1]**

For Override (master) and Mute (master), select the group that controls on/off. For override (Ch), select the channel that controls on/off.

**[OUTPUT TYPE]**

Specifies how output will occur from the [GPI OUT] connector.

**● If [FUNCTION] is [MTX Level]**

Controls the GPI Output according to the level (volume changes) of each channel. You can use this to fader-start a CD player, or to light an indicator when high volume occurs.

Select one of the following parameter types, and then make the appropriate setting.

- Input Ch Level
- Fx RTN Level
- Matrix Out Level
- ZONE Out Level
- Output Ch Level
- 1st Priority Mix Level
- 2nd Priority Mix Level
- Input Ch DCA Group
- ZONE Out DCA Group

**[DEVICE]**

Select the device that you want to change.

**[PARAMETER1]**

Specify the channel that will be used to control the [GPI OUT] connector.

**[OUTPUT TYPE]**

Specifies how output will occur from the [GPI OUT] connector.

**[Threshold]**

Specifies the threshold value of the parameter. The values that can be specified will depend on the type of parameter.

**[Direction]**

Specifies the direction of change for the parameter that will control the [GPI OUT] connector.

**● If [FUNCTION] is [MTX ON]**

Parameter on/off operations on the specified device will control the GPI Output. Select one of the following parameter types, and then make the appropriate setting.

- Input Ch ON
- Fx RTN ON
- ZONE Out ON
- Output Ch ON
- Input Ch Mute Group
- ZONE Out Mute Group

**○ [DEVICE]**

Select the device that you want to change.

**○ [PARAMETER1]**

Specifies the channel whose on/off operations will control the [GPI OUT] connector.

**○ [OUTPUT TYPE]**

Specifies how output will occur from the [GPI OUT] connector.

**○ [Threshold]**

Indicates the threshold value of the parameter. This is fixed at 0.5.

**○ [Direction]**

Specifies the direction of change for the parameter that will control the [GPI OUT] connector. This is shown if [OUTPUT TYPE] is set to [Pulse] or [Pulse Inv.].

**● If [FUNCTION] is [MTX Send Level]**

Controls the GPI Output according to the send level (volume changes) of each channel. You can use this to fader-start a CD player, or to light an indicator when high volume occurs. Select one of the following parameter types, and then make the appropriate setting.

- Input Ch Send Level
- Fx RTN Send Level

For details on these settings, refer to [If \[FUNCTION\] is \[MTX Level\]](#).

**● If [FUNCTION] is [MTX Send ON]**

Send on/off operations will control the GPI Output.

Select one of the following parameter types, and then make the appropriate setting.

- Input Ch Send ON
- Fx RTN Send ON

For details on these settings, refer to [If \[FUNCTION\] is \[MTX ON\]](#).

**● If [FUNCTION] is [MTX Priority Ducker ON]**

On/off operations of the zone’s Ducker will control the GPI Output.

Select one of the following parameter types, and then make the appropriate setting.

- 1st Priority
- 2nd Priority

For details on these settings, refer to [If \[FUNCTION\] is \[MTX Priority Ducker ON\] \(switch only\)](#).

**● If [FUNCTION] is [SD Song Play]**

The status of audio file playback will be output to the [GPI OUT] connector.

**○ [DEVICE]**

Select the device that you want to change.

**○ [OUTPUT TYPE]**

Specifies how output will occur from the [GPI OUT] connector.

**● If [FUNCTION] is [Alert]**

A signal will be output to the [GPI OUT] connector when an alert occurs.

**○ [DEVICE]**

Selects the device whose [GPI OUT] connector will output the alert.

**○ [PARAMETER1]**

Select the type of alert from the following.

- Fault, Error, Warning
- Fault, Error
- Fault

For details on the type of alert that is output, refer to “[Alert list](#)”.

**○ [OUTPUT TYPE]**

Only Closed can be selected. If an alert is occurring, the [GPI OUT] connector will be closed. The closed state will continue until the alert has been cleared.

# Workflow for paging settings

The workflow for making paging settings is as follows. For specific settings, refer to “MTX Setup Manual.”

## Notice

Input channels to which audio signals from a PGM1 are assigned should not be mixed in the “MATRIX” screen. If these signals are mixed, the input from the PGM1 units will be output to the zone even if PTT is off.

1. In the “Device Config Wizard” dialog box, configure the PGM1.

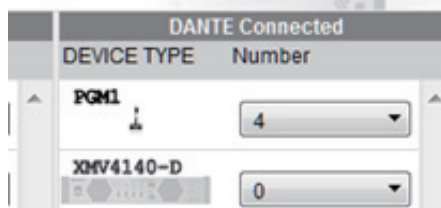

2. In the “Device Config Wizard” dialog box, specify which PGM1 unit will be the 1st Priority Mic, and expand PGX1 units as necessary.

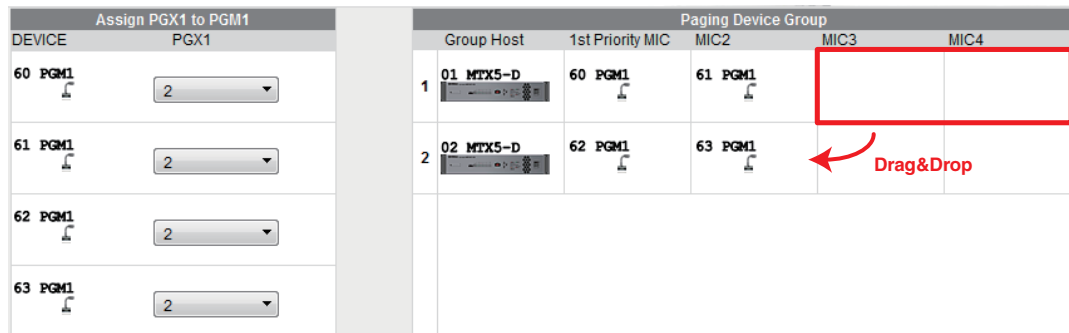

3. In the [DANTE] screen of the [EXT. I/O] screen, patch the PGM1's output to the input of the MTX5-D.

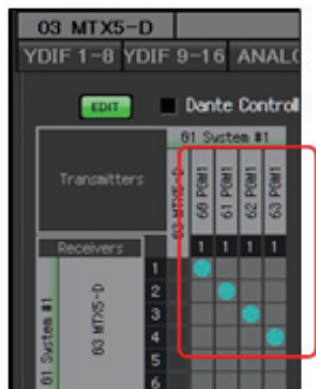

- In the input channel port selection screen of the “MAIN” screen, assign the input from the PGM1 to an input channel.



**Notice**

Input channels to which audio signals from a PGM1 are assigned should not be mixed in the “MATRIX” screen. If these signals are mixed, the input from the PGM1 units will be output to the zone even if PTT is off.

- In the “PAGING” screen of the “ZONE” screen, assign the input from the 1st Priority Mic specified in step 2 to 1st MIC.

In this example, CH1 is assigned to 1st Mic, CH2 to Mic2, CH3 to Mic3, CH4 to Mic4, and STIN3L to SD.



- As necessary, specify zone groups (collections of zones) in the right side of the “PAGING” screen of the “ZONE” screen.

By assigning a Zone Group to a single zone/message select button of the PGM1, you can lower the Program volume for multiple zones and broadcast using the PGM1.



- 7.** In the “PAGING” screen of the “ZONE” screen, click the [Settings] button, and in the [Function Assign] tab, assign functions to the zone/message select buttons of the PGM1/PGX1.

FUNCTION		PARAMETER		FUNCTION		PARAMETER	
1	Zone Group	3:All		5	No Assign		
2	Zone Group	1:1F		6	Zone Group	2:2F	
3	No Assign			7	No Assign		
4	SD Message	Opening.mp3	...	8	All Zone Off		

- 8.** In the [Properties] tab, make settings for the opening chime, etc.

MTX/MRX System

When system enters emergency mode,

Block all paging.

Block paging except for 1st priority PGM1.

Paging Device Group

Opening Chime  ...

Closing Chime  ...

Maximum paging duration

Give priority to paging events set via Scheduler (except for 1st priority PGM1).

# Settings for controlling devices across subnets

If you are controlling devices on a subnet that is different than that of MTX-MRX Editor, all devices are distinguished by their IP address.

For this reason, it is necessary to make settings so that the IP settings of devices placed in MTX-MRX Editor (these are called virtual devices) match the IP settings of devices on the network (these are called real devices).

The IP settings of virtual devices are made in the “Match Devices by IP Address” dialog box, and the IP settings of real devices are made in the “IP Address” dialog box.

The following things are not possible between real devices that are assigned to different subnets.

- Preset Link
- Dante audio communication

Set the IP addresses so that they are unique for the entire communication path. If devices of the same IP address exist on the communication path, they might not be distinguishable.

First, use the “Match Devices by IP Address” dialog box to specify IP addresses for the virtual devices.

**1. In MTX-MRX Editor’s [System] menu, click [Match Device by IP Address].**

The “Match Devices by IP Address” dialog box opens.

**2. Select the [Identify devices with IP Address] check box.**

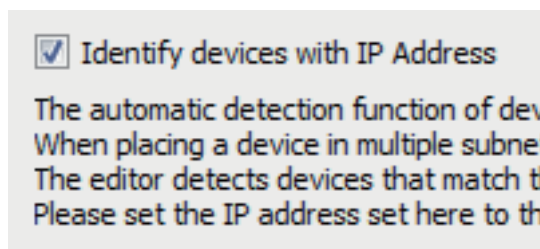

**3. Click the tab of the system for which you want to specify IP addresses.**

Unit ID	Type	Device Name	IP Address
01	MTX5-D	MTX5-D	
02	MTX3	MTX3	
03	EXi8	EXi8	
04	EXo8	EXo8	
05	Rio3224-D	Rio3224-D	
30	XMV4280	XMV4280	
31	XMV8280	XMV8280	
32	XMV4280	XMV4280	

**4. Specify the system’s subnet mask and default gateway, and the IP address of each device.**

If it is OK for the IP addresses to be consecutive, proceed as follows.

**4-1. In the “IP Address Range Finder” area’s IP Address field, enter the IP address that you want to use.**

**4-2. In the [Subnet Mask] list box, select the subnet mask.**

**4-3. Click the [Find Range] button.**

“Range” shows the IP address setting range.

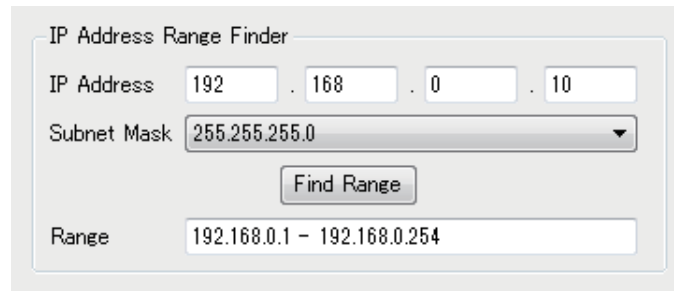

The IP Address Range Finder dialog box contains the following fields and controls:

- IP Address:** 192 . 168 . 0 . 10
- Subnet Mask:** 255.255.255.0
- Find Range:** Button
- Range:** 192.168.0.1 - 192.168.0.254

**4-4. Click the [Apply IP Address] button.**

IP addresses are automatically assigned to the virtual devices in the system.

**5. Click the [Apply] button.**

**6. Repeat steps 3 through 5 to assign IP addresses to all virtual devices.**

**7. When you have finished making settings, click the [OK] button.**

Next, use the “IP Address” dialog box to specify IP addresses for the real devices.

When doing so, make settings that match the IP addresses of the virtual devices that were specified in the “Match Devices by IP Address” dialog box.

**1. Set the computer’s IP address to “192.168.0.253” and the subnet mask to “255.255.255.0”.**

**2. As the device’s settings, set IP SETTINGS to [UNIT ID] or set IP SELECT MODE / IP Address Mode to [STATIC (IP) (Auto)], set the UNIT ID of all devices to something other than FD so that none of the devices conflict, and then power-on the devices.**

**3. While still offline, click MTX-MRX Editor’s [System] menu item [Device Information].**

The “Device Information” dialog box opens.

**4. When all devices are shown in the “Device Information” dialog box, click the [IP Address] button.**

The “IP Address” dialog box opens.

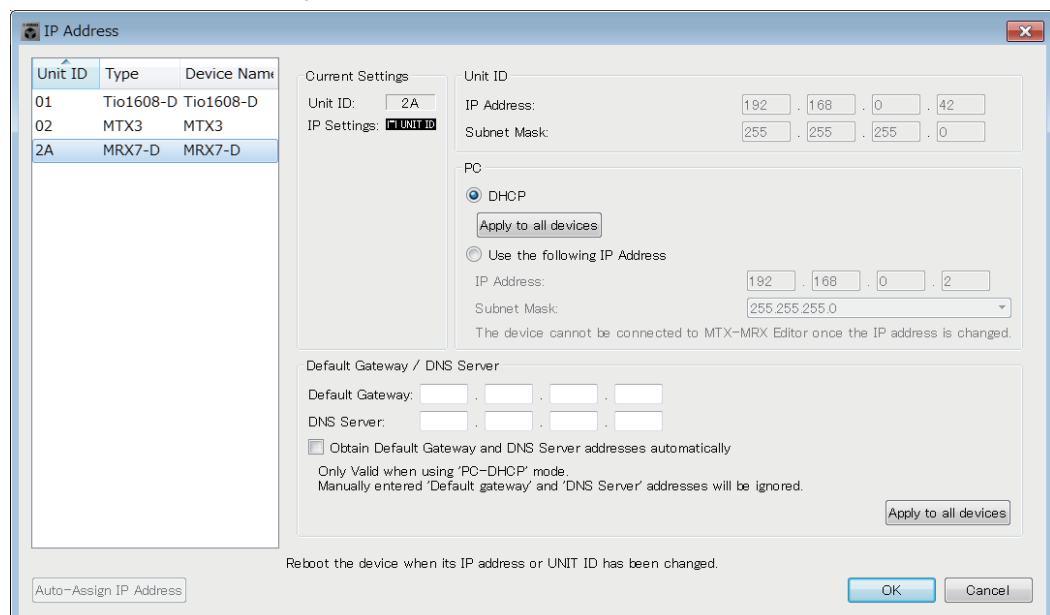

The IP Address dialog box contains the following elements:

- Table:**

Unit ID	Type	Device Name
01	Tio1608-D	Tio1608-D
02	MTX3	MTX3
2A	MRX7-D	MRX7-D
- Current Settings:**
  - Unit ID: 2A
  - IP Settings: UNIT ID
- Unit ID:** 2A
- IP Address:** 192 . 168 . 0 . 42
- Subnet Mask:** 255 . 255 . 255 . 0
- PC:**
  - DHCP
  - Use the following IP Address
- Apply to all devices:** Button
- IP Address (Static):** 192 . 168 . 0 . 2
- Subnet Mask (Static):** 255.255.255.0
- Default Gateway / DNS Server:**
  - Default Gateway: [ ] . [ ] . [ ] . [ ]
  - DNS Server: [ ] . [ ] . [ ] . [ ]
  - Obtain Default Gateway and DNS Server addresses automatically
  - Only Valid when using 'PC-DHCP' mode.
  - Manually entered 'Default gateway' and 'DNS Server' addresses will be ignored.
- Apply to all devices:** Button
- Auto-Assign IP Address:** Button
- Reboot the device when its IP address or UNIT ID has been changed.** (Text)
- OK** and **Cancel** buttons.

- Click the [Auto-Assign IP Addresses] button so that the virtual device IP settings specified in the “Match Devices by IP Address” dialog box are applied to the “IP Address” dialog box.

The “Auto-Assign IP Addresses” dialog box opens.

The IP settings of the virtual devices are shown.

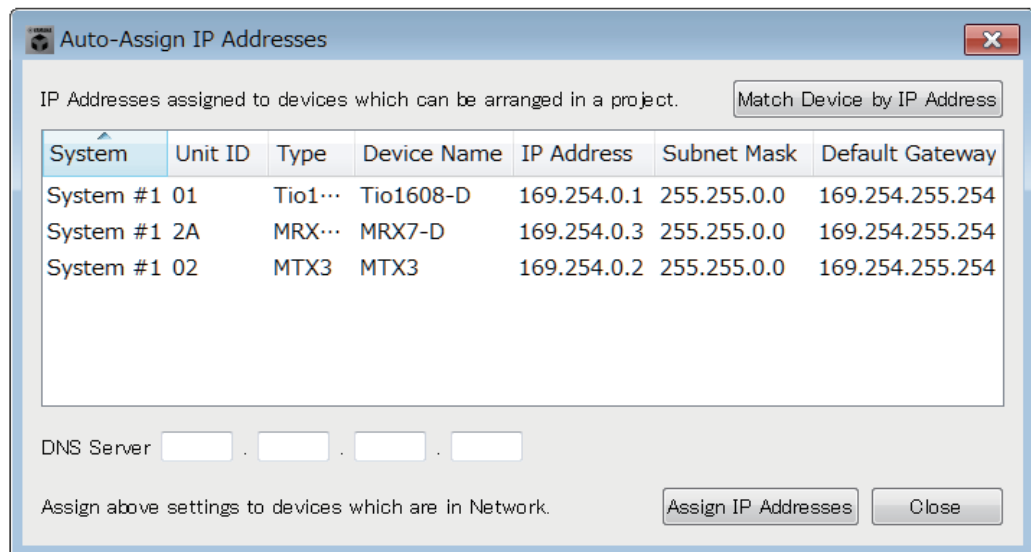

- If you need to connect to a DNS server, specify the [DNS Server] setting.

- If there are no problems with the IP settings of all devices, click the [Assign IP Addresses] button.

The settings are applied to the “IP Address” dialog box.

If there is a problem or if you want to change the settings, click the [Match Device by IP Address] button, make the settings in the “Match Devices by IP Address” dialog box, and then click the [Assign IP Addresses] button once again.

You can also make IP settings for the real devices manually while referring to the IP settings of the virtual devices. In this case, in the “IP Address” dialog box, select the [Use the following IP Address] option button, and then enter the [IP Address] and [Subnet Mask].

- In the “IP Address” dialog box, select the device and click the [OK] button.

The settings are applied to the real device.

- In the device’s settings, set IP SETTINGS to [PC] or set IP SELECT MODE / IP Address Mode to [STATIC IP (MANUAL)], and then restart.

This completes the settings.

**NOTE** If the “Match Devices by IP Address” dialog box’s [Identify devices with IP Address] check box is selected, use the IP address to associate the virtual device and real device. If the IP addresses of the virtual device and the real device are different, the devices are shown both in the Project screen’s network device area and in the MTX/MRX system’s area, even if the UNIT ID is the same.

# Alert list

The alerts generated by the MTX/MRX and the XMV, and their significance and the appropriate actions, are listed below.

The number is shown as two digits on the MTX/MRX unit, and as three digits on the XMV unit.

A single alert is shown when the event occurs. A continuing alert is shown when the event occurs and when it ends.

Some alerts and information are shown in MTX-MRX Editor but not shown on the unit itself.

If the problem is not solved, please contact a Yamaha service center listed at the end of the device's owner's manual.

Number	Content	Action	Type	Single/ Continuing
<b>Device abnormality</b>				
1-9	The device has not started up correctly.	Turn the power off, then turn on after waiting at least 6 seconds. If this does not solve the problem, please initialize the memory. Should this also fail, contact your Yamaha dealer.	Fault	Continuing
10	The internal backup battery is completely exhausted, or is not installed.	When you turn off the power, the current settings will be lost, and will return to the default values. Please stop use immediately, and contact your Yamaha dealer.	Fault	Continuing
11	The internal backup battery has run extremely low, and it is possible that the internal memory has been cleared.	When you turn off the power, the current settings will be lost, and will return to the default values. Please stop use immediately, and contact your Yamaha dealer.	Error	Continuing
12	The internal backup battery has only a small amount of power remaining.	This does not affect the operation of the device. However, if you continue using the device, the settings may be lost and reset to the default values. Contact your Yamaha dealer as soon as possible.	Warning	Single
13	A problem has occurred with the internal clock, and it has been initialized (January 1, 2000, 0:00).	If this occurs each time you turn on the power, it is possible that the internal backup battery has run down or that the device has malfunctioned. Contact your Yamaha dealer. If this occurs only once, an abnormality was detected with the clock setting and it was initialized; use MTX-MRX Editor to set the time.	Fault	Continuing
14	The current preset saved in internal memory has been lost.	Recall the preset. If this does not solve the problem, contact your Yamaha dealer.	Fault	Continuing
15	The settings saved in internal memory have been lost.	Either the internal backup battery has run low, or the device has malfunctioned. Contact your Yamaha dealer.	Fault	Continuing
16	A memory problem has occurred.	Contact your Yamaha dealer.	Fault	Continuing
19	The device has not started up correctly.	Contact your Yamaha dealer.	Fault	Continuing
20	An unsupported Mini-YGDAI card is inserted in the slot, or the inserted Mini-YGDAI card has malfunctioned.	Replace the card with a supported Mini-YGDAI card or check that the supported Mini-YGDAI card is working correctly in another Host.	Fault	Continuing

Number	Content	Action	Type	Single/ Continuing
21	The word clock master has become unlocked.	Make sure that the word clock signal is being input correctly.	Error	Continuing
22	The digital signal being input to the [YDIF IN] connector is not synchronized to the word clock of this device.	Make sure that YDIF cables are properly connected. Use cables that meet the required specifications.	Error	Single
23	The digital signal being input to the [YDIF IN] connector is not continuously synchronized to the word clock of this device.		Error	Continuing
24	The digital signal being input to the slot is not synchronized to the word clock of this device.	Either input a signal that is synchronized, or specify the slot as the word clock master.	Warning	Single
25	The digital signal being input to the slot is not continuously synchronized to the word clock of this device.		Warning	Continuing
26	The digital signal being input to the Dante connector is not synchronized to the word clock of this device.	Either input a signal that is synchronized, or specify the Dante connectors as the word clock master.	Warning	Single
27	The digital signal being input to the Dante connector is not continuously synchronized to the word clock of this device.		Warning	Continuing
30	There is a problem with the connection of the [YDIF IN] connector.	Make sure that YDIF cables are properly connected. Use cables that meet the required specifications.	Error	Continuing
40	Duplicate IP addresses.	Change the IP addresses so that there are no duplicates.	Error	Continuing
41	IP address was not set within 60 seconds of startup.	Please check rear panel DIP switch 6 (IP Setting). If DIP switch 6 is set to "PC," use MTX-MRX Editor or DHCP server to specify the device IP address.	Warning	Continuing
42	A device within the MTX/MRX system was not found on the network.	Power-on all devices in the system, and make sure that they are correctly connected to the network.	Error	Continuing
43	Too many devices are connected to the network.	Reduce the number of devices connected to the network.	Error	Single
44	A timeout has occurred in synchronization to the time server or the server reply is invalid.	Check the time server condition or set another time server.	Error	Single
45	The host name of the time server can not be resolved by DNS server.	Check the setting of the time server, DNS server address or make sure that the DNS server works correctly.	Error	Single
46	Dante received flow count exceeded the limit.	Maximum Dante Flow rate exceeded. Try changing parts of transmission flows to Multicast using Dante Controller.	Error	Single
50	The UNIT ID is set to "00."	Set the UNIT ID to something other than "00."	Error	Continuing

Number	Content	Action	Type	Single/ Continuing
51	Devices with identical UNIT IDs were found connected within the same network.	Change the UNIT ID so that there are no duplicates.	Error	Continuing
52	A communication error occurred with the [DCP] connection.	<ul style="list-style-type: none"> <li>• If an error was shown in the DCP panel, refer to the DCP owner's manual and take the appropriate action.</li> <li>• Ensure that the panel ID of the DCP units do not conflict.</li> <li>• Verify that the cables are correctly connected and are within the specified length.</li> </ul>	Error	Single
53	The DCP[*] connected to the [DCP] connector has been configured differently from the project settings.	<ul style="list-style-type: none"> <li>• Check that the required DCP is connected.</li> <li>• Check whether a different model of DCP might be connected.</li> </ul>	Error	Continuing
56	SD memory card was not recognized.	Use an SD memory card that complies with the specifications.	Error	Continuing
58	Unable to play the specified file or folder in the SD player.	Verify that the specified audio file or folder exists in the SD memory card. There must be at least one playable audio file in the specified folder.	Warning	Single
60	A preset recall attempt has failed.	Initialize the memory of the device (use rear panel DIP switches 7 and 8). If this does not solve the problem, contact your Yamaha dealer.	Error	Continuing
61	The recall could not be executed because the preset to be recalled when the MTX/MRX starts up was not found.	Specify a preset that exists. No sound will be output unless an appropriate preset is recalled.	Error	Continuing
62	A snapshot/snapshot group recall attempt has failed.	Initialize the memory of the device (use rear panel DIP switches 7 and 8). If this does not solve the problem, contact your Yamaha dealer.	Error	Continuing
63	The snapshot/snapshot group could not be recalled.	<ul style="list-style-type: none"> <li>• The Snapshot selected for recall cannot be recalled as no data has been stored to it.</li> <li>• Another device may have been added after snapshots were stored. Please synchronize and check all snapshots/snapshot groups using Editor, edit as necessary and store again.</li> </ul>	Warning	Single
64	The preset could not be recalled.	<ul style="list-style-type: none"> <li>• The Preset selected for recall cannot be recalled as no data has been stored to it.</li> <li>• Another device may have been added after presets were stored. Please synchronize and check all presets using MTX-MRX Editor, edit as necessary and store again.</li> </ul>	Warning	Continuing
65	Invalid parameters set for GPI IN.	Check the GPI IN settings and perform synchronization again.	Error	Continuing
66	Invalid parameters set for GPI OUT.	Check the GPI OUT settings and perform synchronization again.	Error	Continuing
67	Invalid parameters set for DCP[*].	Check the DCP[*] settings and perform synchronization again.	Error	Continuing

Number	Content	Action	Type	Single/ Continuing
70	Synchronization has not been completed. It may be that synchronization was halted before completion.	Perform synchronization again using MTX-MRX Editor. If this does not solve the problem, initialize the memory of the device and synchronize again. If this also fails, contact your Yamaha dealer.	Error	Continuing
71	The UNIT ID settings when synchronization was performed do not match the current UNIT ID settings.	Do not change any UNIT ID's after performing synchronization. If you've changed any UNIT ID's, perform synchronization again.	Error	Continuing
72	Because this device has Dante Device Lock enabled, the settings of device DIP switches and MTX - MRX Editor do not match current Dante settings.	To solve the mismatch, please review device DIP switch settings and MTX - MRX Editor's Dante settings, and edit as necessary to match the current situation. Or please disable Device Lock using Dante Controller.	Error	Continuing
80	Speech Privacy Audio File not installed.	Install the Speech Privacy Audio File.	Warning	Continuing
<b>Amp problems</b>				
100	The power supply was shut down because d.c. was detected on a speaker output.	It is likely that the device has malfunctioned; immediately stop using the device and contact your Yamaha dealer.	Fault	Continuing
101	The power supply was shut down because its temperature exceeded the allowed limit.	Turn the power off, let the power supply cool down, then turn the power on again. Continuous high-power output will cause high temperatures, so please lower the output level. If the temperature is still high, check whether dirt or a foreign object could have clogged the cooling fan, and clean the fan if necessary.	Fault	Continuing
103	Protection has been activated, and the power supply was shut down.	Continuous high-power output may have activated protection; lower the output level. For details on the reason that protection was activated, refer to the owner's manual.	Error	Continuing
104	Protection has been activated, and muted.[ch*]		Error	Continuing
105	A short circuit was detected in the speaker output connector[ch*], so the output signal has been muted.	It may be that the speaker output connector's "+" and "-" are shorted, or that the connected speaker has malfunctioned.	Fault	Single
106	The temperature of the amp section (heat sink) has changed, and the speaker output is now ****.	Continuous high-power output will cause high temperatures, so please lower the input level or attenuator. If the temperature is still high, check whether dirt or a foreign object could have clogged the cooling fan's air intake, and clean it if necessary.	Warning	Single

Number	Content	Action	Type	Single/ Continuing
<b>Device information</b>				
200	The power to the device has been turned on.	–	Information	Single
201	The power to the device has been turned off.	–	Information	Single
202	The firmware update has been completed.	–	Information	Single
203	Initialization has been executed.	–	Information	Single
204	Panel lock has been disabled.	–	Information	Single
205	The IP address has been established.	–	Information	Single
206	The network IP address has been allocated from the DHCP server.	–	Information	Single
207	The network IP address has been released by the DHCP server.	–	Information	Single
208	An EMG (Emergency) signal was received, and the device switched to EMG mode.	–	Information	Continuing
209	The setting of the internal clock has been changed.	–	Information	Single
210	The event has been executed using the scheduler.	–	Information	Single
211	MTX-MRX Editor began synchronisation.	–	Information	Single
213	A login failure has occurred from an external remote controller via the remote control protocol.	–	Information	Single
214	A login authentication has been successfully completed from an external remote controller via the remote control protocol.	–	Information	Single
215	The SD memory card has been mounted properly.	–	Information	Single
216	The SD memory card was removed while the MTX was turned on.	–	Information	Single
217	Preset number ** was recalled.	–	Information	Single
218	Preset number ** was stored.	–	Information	Single
220	The clock has been successfully synchronized by the time server.	–	Information	Single
221	Preset number ** was edited.	–	Information	Single

Number	Content	Action	Type	Single/ Continuing
222	A snapshot/snapshot group was recalled.	–	Information	Single
223	Snapshot was stored.	–	Information	Single
224	Snapshot was edited.	–	Information	Single
225	Snapshot group was edited.	–	Information	Single
<b>Amp information</b>				
102	Protection has been activated, and the limiter[ch*] is in operation.	Continuous high-power output may have activated protection; lower the output level. For details on the reason that protection was activated, refer to the owner's manual.	Information	Continuing
110	The Redundant Backup function has operated, and channel * has switched to analog input.	There is a problem with the digital signal. Check the connection of the digital circuit, and check whether a Pilot Tone signal is being input.	Error	Continuing
219	The Power Amp Mode was changed.	–	Information	Single
226	The Redundant Override function has operated, and channel * has switched to analog input.	–	Information	Continuing

# Troubleshooting

Problem	Possible cause	Action
<p><b>MTX-MRX Editor can't communicate with the device.</b></p>	<p>The IP address setting of the computer is incorrect.</p>	<p>Refer to "MTX Setup Manual" or "MRX Setup Manual," and specify the IP address of the computer.</p>
		<p><b>Windows 7 users:</b> Click [Start]→[Control Panel]→[System and Security]→[Allow an App through Windows Firewall], then click the [Change settings] button, and select the check boxes for "Bonjour service" and "MTX-MRX Editor." If MTX-MRX Editor is not in the list, click the [Allow another app] button, add MTX-MRX Editor, and select its check box. <b>NOTE</b> Set the control panel view to [Category].</p>
	<p>A firewall is blocking communication.</p>	<p><b>Windows 8.1 users:</b> Click [Windows] key + [X] key →[Control Panel]→[System and Security]→[Allow an App through Windows Firewall], then click the [Change settings] button, and select the check boxes for "Bonjour service" and "MTX-MRX Editor." If MTX-MRX Editor is not in the list, click the [Allow another app] button, add MTX-MRX Editor, and select its check box. <b>NOTE</b> Set the control panel view to [Category].</p>
		<p><b>Windows 10 users:</b> Right-click [Start]→[Control Panel]→[System and Security]→[Allow an App through Windows Firewall]; then click the [Change settings] button, and select the check boxes for "Bonjour service" and "MTX-MRX Editor." If MTX-MRX Editor is not in the list, click the [Allow another app] button, add MTX-MRX Editor, and select its check box. <b>NOTE</b> Set the control panel view to [Category].</p>
<p><b>Can't specify the device's IP address from the DHCP server.</b></p>	<p>The device was started up before the DHCP server.</p>	<p>Start up the DHCP server before you start up the device.</p>
	<p>The device's IP SETTING is set to UNIT ID.</p>	<p>Use the device's DIP switch to set IP SETTING to PC.</p>
<p><b>A device is not shown in the Project window.</b></p>	<p>The device or the network switch is not powered-on.</p>	<p>Power-on the device and the network switch. Also, it will take several seconds after the device is powered-on until it is shown in the Project window.</p>
	<p>IP addresses conflict between devices on the network.</p>	<p>If IP SETTING is set to UNIT ID, set the UNIT ID of the devices in the network so that they do not conflict. If IP SETTING is set to PC, use the "IP Address" dialog box to specify an IP address that does not conflict. UNIT ID conflicts can be viewed in the "Device Information" dialog box.</p>
	<p>The upper three numbers of the computer's IP address do not match the upper three numbers of the device's IP address.</p>	<p>In the "IP Address" dialog box, set the IP address so that the upper three numbers match. <b>NOTE</b> If the subnet mask is set to 255.255.0.0, set the upper two numbers to match.</p>
	<p>The device is connected to something other than the NETWORK connector.</p>	<p>Connect the device to the NETWORK connector.</p>
	<p>An incorrect network card is selected.</p>	<p>In the "Network Setup" dialog box, select the network card that is connected to the device.</p>

Problem	Possible cause	Action
<b>Can't monitor or control the device.</b>	The system is offline.	In the toolbar, click the [Online] button to go online.
	In the Project window, the device is in the list of network devices.	There is an inconsistency between the settings of MTX-MRX Editor and the settings of the device. Either use the <a href="#">"Device Configuration Wizard" dialog box</a> to change the settings in MTX-MRX Editor, or change the settings of the device.
<b>Preset data saved in the MTX/MRX has disappeared.</b>	The power supply was stopped while MTX/MRX data was being saved.	Synchronize once again with MTX-MRX Editor and send the settings data.
<b>Can't go online in the "Go Online – From devices" dialog box.</b>	The MTX/MRX has never been online with MTX-MRX Editor in To Device.	Using the applicable project, use To Device to put the MTX/MRX and MTX-MRX Editor online.
<b>No sound is output.</b>	A cable is broken or disconnected.	Check whether the cables between each device are connected correctly. If the cables are connected correctly, check whether they might be broken, and replace any that are broken.
	The DIP switches on the unit are set incorrectly.	Check the setting of the DIP switches on the unit. In particular if START UP MODE is set to INIT., there will be no sound unless the unit synchronizes with MTX-MRX Editor each time the power is turned on.
	The settings in MTX-MRX Editor are incorrect.	Check the settings of MTX-MRX Editor. In particular for YDIF, make sure that the "EXT. I/O" settings match the port settings of the input/output channels.
	The XMV is in double power mode.	In double power mode, the B/D/F/H channel output is disabled. Either cancel double power mode, or use the Editor to specify a different channel.